



Data General Corporation, Westboro, Massachusetts 01580

Customer Documentation

**Setting Up, Starting,
Expanding, and Maintaining
AViiON[®] 530 and 4600 Series
Computers**

014-002091-01

A V i i O N[®]
P R O D U C T L I N E

Setting Up, Starting, Expanding, and Maintaining AViiON[®] 530 and 4600 Series Computers

014-002091-01

Copyright ©Data General Corporation, 1991, 1992
All Rights Reserved
Printed in the United States of America
Rev. 01, June, 1992
Ordering No. 014-002091

Notice

DATA GENERAL CORPORATION (DGC) HAS PREPARED THIS DOCUMENT FOR USE BY DGC PERSONNEL, CUSTOMERS, AND PROSPECTIVE CUSTOMERS. THE INFORMATION CONTAINED HEREIN SHALL NOT BE REPRODUCED IN WHOLE OR IN PART WITHOUT DGC'S PRIOR WRITTEN APPROVAL.

DGC reserves the right to make changes in specifications and other information contained in this document without prior notice, and the reader should in all cases consult DGC to determine whether any such changes have been made.

THE TERMS AND CONDITIONS GOVERNING THE SALE OF DGC HARDWARE PRODUCTS AND THE LICENSING OF DGC SOFTWARE CONSIST SOLELY OF THOSE SET FORTH IN THE WRITTEN CONTRACTS BETWEEN DGC AND ITS CUSTOMERS. NO REPRESENTATION OR OTHER AFFIRMATION OF FACT CONTAINED IN THIS DOCUMENT INCLUDING BUT NOT LIMITED TO STATEMENTS REGARDING CAPACITY, RESPONSE-TIME PERFORMANCE, SUITABILITY FOR USE OR PERFORMANCE OF PRODUCTS DESCRIBED HEREIN SHALL BE DEEMED TO BE A WARRANTY BY DGC FOR ANY PURPOSE, OR GIVE RISE TO ANY LIABILITY OF DGC WHATSOEVER.

IN NO EVENT SHALL DGC BE LIABLE FOR ANY INCIDENTAL, INDIRECT, SPECIAL OR CONSEQUENTIAL DAMAGES WHATSOEVER (INCLUDING BUT NOT LIMITED TO LOST PROFITS) ARISING OUT OF OR RELATED TO THIS DOCUMENT OR THE INFORMATION CONTAINED IN IT, EVEN IF DGC HAS BEEN ADVISED, KNEW OR SHOULD HAVE KNOWN OF THE POSSIBILITY OF SUCH DAMAGES.

AViiON, CEO, DASHER, DATAPREP, DESKTOP GENERATION, ECLIPSE, ECLIPSE MV/4000, ECLIPSE MV/6000, ECLIPSE MV/8000, GENAP, INFOS, microNOVA, NOVA, PRESENT, PROXI, SWAT, TRENDVIEW, and WALKABOUT are U.S. registered trademarks of Data General Corporation; and **AOSMAGIC, AOS/VSMAGIC, AROSE/PC, ArrayPlus, AV Object Office, AV Office, BaseLink, BusiGEN, BusiPEN, BusiTEXT, CEO Connection, CEO Connection/LAN, CEO Drawing Board, CEO DXA, CEO Light, CEO MAILL, CEO Object Office, CEO PXA, CEO Wordview, CEOWrite, COBOL/SMART, COMPUCALC, CSMAGIC, DASHER/One, DASHER/286, DASHER/286-12c, DASHER/286-12j, DASHER/386, DASHER/386-16c, DASHER/386-25, DASHER/386-25k, DASHER/386SX, DASHER/386SX-16, DASHER/386SX-20, DASHER/486-25, DASHER II/486-33TE, DASHER/LN, DATA GENERAL/One, DESKTOP/UX, DG/500, DG/AROSE, DGConnect, DG/DBUS, DG/Fontstyles, DG/GATE, DG/GEO, DG/HEO, DG/L, DG/LIBRARY, DG/UX, DG/XAP, ECLIPSE MV/1000, ECLIPSE MV/1400, ECLIPSE MV/2000, ECLIPSE MV/2500, ECLIPSE MV/3500, ECLIPSE MV/5000, ECLIPSE MV/5500, ECLIPSE MV/5600, ECLIPSE MV/7800, ECLIPSE MV/9300, ECLIPSE MV/9500, ECLIPSE MV/9600, ECLIPSE MV/10000, ECLIPSE MV/15000, ECLIPSE MV/18000, ECLIPSE MV/20000, ECLIPSE MV/30000, ECLIPSE MV/40000, ECLIPSE MV/60000, FORMA-TEXT, GATEKEEPER, GDC/1000, GDC/2400, Intellibook, microECLIPSE, microMV, MV/UX, PC Liaison, RASS, REV-UP, SLATE, SPARE MAIL, SUPPORT MANAGER, TEO, TEO/3D, TEO/Electronics, TURBO/4, UNITE, and XODIAC** are trademarks of Data General Corporation.

UNIX is a U.S. registered trademark of Unix System Laboratories, Inc.

NFS is a U.S. registered trademark and **ONC** is a trademark of Sun Microsystems, Inc.

The Network Information Service (NIS) was formerly known as Sun Yellow Pages. The functionality of the two remains the same; only the name has changed. The name **Yellow Pages** is a registered trademark in the United Kingdom of British Telecommunications plc and may not be used without permission.

IBM PC AT is a U.S. registered trademark of International Business Machines Corporation.

Teflon is a U.S. registered trademark of E.I. DuPont de Nemours and Company.

Setting Up, Starting, Expanding, and Maintaining AViiON® 530 and 4600 Series Computers

014-002091-01

Revision History:

Original Release - September, 1991

First Revision - June, 1992

A vertical bar in the margin of a page indicates substantive technical change from the previous revision.

NOTE

This equipment has been tested and found to comply with the limits for a Class A digital device, pursuant to Part 15 of the FCC Rules. These limits are designed to provide reasonable protection against harmful interference when the equipment is operated in a commercial environment. This equipment generates, uses, and can radiate radio frequency energy and, if not installed and used in accordance with the instruction manual, may cause harmful interference in which case the user will be required to correct the interference at his own expense. Testing was done with shielded cables. Therefore, in order to comply with the FCC regulations, you must use shielded cables with your installation.

WARNING

Changes or modifications to this unit not expressly approved by the party responsible for compliance could void the user's authority to operate the equipment.

This device complies with Part 15 of the FCC rules. Operation is subject to the following two conditions:

(1) this device may not cause harmful interference, and (2) this device must accept any interference received, including interference that may cause undesired operation.

This digital apparatus does not exceed the Class A limits for radio noise emissions from digital apparatus set out in the Radio Interference Regulations of the Canadian Department of Communications.

Le présent appareil numérique n'émet pas de bruits radioélectriques dépassant les limites applicables aux appareils numériques de la classe A prescrites dans le Règlement sur le brouillage radioélectrique édicté par le ministère des Communications du Canada.

この装置は、第一種情報装置（商工業地域において使用されるべき情報装置）
で商工業地域での電波障害防止を目的とした情報処理装置等電波障害自主規制

協議会（VCCI）基準に適合しております。従って、住宅地域またはその隣接した地域で使用すると、ラジオ、テレビジ
ョン受信機等に受信障害を与えることがあります。取扱説明書に従って正しい取り扱いをして下さい。

Preface

We wrote this manual for anyone who sets up and maintains AViiON® 530 and 4600 series computer system hardware. Although it addresses readers with some computer hardware experience, you do not need knowledge of AViiON or RISC-based computer technology to use this manual.

The first three chapters of this manual describe how to unpack, set up, and start a basic new computer system. They cover a hardware installation sequence that ends with you ready to install your system software. Subsequent chapters explain how to set up and connect external mass-storage units, and how to customize operating parameters for devices connected directly to the system board. The final six chapters in this manual provide detailed information and illustrated instructions for replacing failing parts and for adding mass-storage devices, expansion memory, and option boards to an installed system. Appendixes provide technical specifications for computer system hardware, instructions for using the System Control Monitor (SCM), and suggestions for solving powerup problems.

NOTE: This manual does not describe how to set up or install VMEbus option boards, or the devices that connect to them. If your system includes VMEbus options, refer to *Setting Up and Installing VMEbus Options in AViiON® Systems* (DGC part number 014-001867) for instructions.

How We Organized This Manual

We organized the information in this manual as follows:

Chapter 1 Getting Started

Provides information you need *before* starting any work. Begins with an overview of base computer system components and options. Also includes site preparation and unpacking instructions, an inventory worksheet for cables and cords, and a checklist to complete before you set up your workstation.

Chapter 2 Setting Up Your Computer System

Describes how to connect the system console and computer unit power cord. For the AViiON 530 series, describes how to install the monitor, keyboard, and mouse. For systems without external mass-storage devices, explains how to terminate an internal SCSI bus. Also describes cabling for the following optional devices:

- asynchronous devices such as a modem, serial printer, or plotter.
- local area network (LAN) transceiver.
- parallel printer.

Chapter 3 Starting and Stopping Your Computer System

Explains how to correctly power the computer system up and down and describes routine firmware powerup testing.

NOTE: Chapter 3 describes a first powerup sequence to the point at which you should install your operating system software. It then provides references to the appropriate documentation for your next step.

Chapter 4 Setting Up and Installing a SCSI Bus

Describes how to configure a Small Computer System Interface (SCSI) bus. Includes default and recommended SCSI identification numbers, operating parameters for individual drives, terminating rules, and cabling restrictions. Also provides worksheets for planning a SCSI configuration, and instructions for connecting external SCSI devices and subsystems to the computer unit.

Chapter 5 Using the SCM Configuration Menus

Describes menus you can use to view or change configuration parameters for devices connected to the system board. Also describes changing the system automatic boot path from the default DG/UX™ installation path.

Chapter 6 Expanding and Maintaining Your Computer System

Provides general procedures you should follow each time you add or replace an internal system component, and describes how to respond to hardware problems. Explains how to review system configuration parameters, and provides instructions and worksheets for calculating the power requirements of proposed configurations.

Further describes how to avoid electrostatic discharge (ESD) damage while working inside the computer unit chassis, and explains how to open and close the chassis covers.

Chapters 7 through 12 Adding and/or Replacing ...

Each of these six chapters describes how to expand your system by adding a new internal component, or maintain the system by replacing a failed Customer Replaceable Unit (CRU). Each refers to Chapter 6 for prerequisite information that applies to all CRUs.

Appendix A Technical Specifications

Lists detailed physical, environmental, and electrical specifications for base hardware and optional components.

Appendix B Using the System Control Monitor

Explains how to reach the system firmware and use basic SCM commands to boot, program, and debug your system.

Appendix C Solving Powerup Problems and Exiting the DG/UX™ Installer

Provides suggestions for resolving powerup problems such as blank screen display or unreadable text messages. Also describes exiting routine first powerup to test your system hardware before installing the DG/UX operating system.

Reading Paths

The following reading paths explain which chapters and sections you should read and in what order, depending on the task you need to do.

Reading Path for Setting Up a New Computer System

Review site requirements, and then unpack and inventory your system, as described in Chapter 1. Then read Chapter 2, following those instructions that apply to your configuration. Read Chapter 3, “Starting and Stopping Your Computer System” before you power up your new computer system.

- If your system includes external SCSI devices or subsystems, set them up as described in Chapter 4 before continuing with the instructions in Chapter 3 to start your system.
- If your system includes VMEbus options (such as a terminal controller or asynchronous device controller), set up and connect the appropriate devices as described in the device-specific documentation and *Setting Up and Installing VMEbus Options in AViiON® Systems*. Then continue with the instructions in Chapter 3 to start your system.
- If your system includes devices connected to the system board whose operating parameters conflict with the defaults listed in Chapter 2 and which are required for the first powerup, read the appropriate instructions in Chapter 5 before continuing with the instructions in Chapter 3 to start your system.

Reading Path for Powerup Procedures or Problems

Refer to Chapter 3, “Starting and Stopping Your Computer System,” for a description of the sequence your computer system undergoes when powering up normally. Refer to Appendix C, “Solving Powerup Problems and Exiting the DG/UX™ Installer,” for troubleshooting suggestions. For steps to properly shut down the computer system, refer to the last section of Chapter 3, “Shutting Down the Computer System.”

Reading Path for Expanding the Computer System

NOTE: To add VMEbus options to your system, first verify your proposed system configuration as described in Chapter 6; then refer to *Setting Up and Installing VMEbus Options in AViiON® Systems*.

Internal CRUs

An internal CRU (Customer Replaceable Unit) is any component you can install *inside* the computer unit chassis. To add an internal part, follow the instructions in Chapter 6 to verify your proposed configuration and open your system; then proceed to the appropriate chapter in this manual.

Adding Mass–Storage Devices

To add a drive to a mass–storage housing unit, verify your proposed SCSI configuration as described in Chapter 4; then refer to the manual that came with the drive and to the manual that came with the housing unit for instructions.

To connect a stand–alone mass–storage drive or housing unit, refer to Chapter 4 and the manual that came with the unit.

To add an internal device, refer first to Chapter 4 to verify your proposed bus configuration, and then refer to Chapter 6 to verify your proposed system configuration. Follow the instructions in Chapter 6 before adding the drive as described in Chapter 7.

Adding an External Option

To add an external option (such as a LAN transceiver, modem, or other externally connected peripheral), follow the steps in the appropriate section of Chapter 2 to configure the device and connect the cabling. Refer to the manual that came with the option for additional information and instructions.

Reading Path for Replacing Parts

NOTE: To replace VMEbus options in or connected to your system, refer to *Setting Up and Installing VMEbus Options in AViiON® Systems*.

Internal CRUs

An internal CRU (Customer Replaceable Unit) is any component you can replace that is housed *inside* the computer unit chassis. To replace an internal part, follow the instructions in Chapter 6 to open your system; then proceed to the appropriate chapter in this manual.

Replacing Mass–Storage Devices

To replace a drive in a mass–storage housing unit, refer to the manual that came with the drive and to the manual that came with the housing unit for instructions. Refer to Chapter 4 for operating parameters.

To replace a stand–alone mass–storage drive or housing unit, refer to Chapter 4 and the manual that came with the unit.

To replace an internal device, follow the instructions in Chapter 6 to open your system before removing and re–installing the drive as described in Chapter 7.

Replacing an External Option

To replace an external option (such as a LAN transceiver, modem, or other externally connected peripheral), follow the steps in the appropriate section of Chapter 2 to configure the replacement device, disconnect the old part, and then reconnect the new part. Refer to the manual that came with the option for additional information and instructions.

Related Documents

You received a comprehensive documentation package with your AViiON 530 or 4600 series computer system. Those documents specifically mentioned within the text of this manual appear below. Refer to the document *Guide to AViiON® and DG/UX™ System Documentation* (069–701085) for a complete list of related documentation.

Customizing the DG/UX™ System (093–701101)

Describes how to perform tasks that customize the DG/UX system to your site's needs. Included are descriptions of how to add user home directories, printers, terminals, third-party packages, operating system clients and secondary releases.

Ethernet/IEEE 802.3 Local Area Network Installation Guide (014–000793)

Explains how to install both the coaxial cable plant of an Ethernet local area network (LAN) and the transceivers that connect the network to a communications controller.

Installing and Maintaining the CSS2/DC (014–002061)

Describes how to unpack, inspect, install, and power up the unit. Explains how to replace the power supply, line cord, fan; and provides general instructions for replacing a drive. Lists physical, electrical, and environmental specifications of the subsystem.

Installing and Operating the Model 10565 Peripheral Housing Unit (014–001810)

Describes how to unpack, inspect, install, and power up the unit. Explains how to replace the power supply, line cord, and fan; and provides general instructions for replacing a drive. Lists physical, electrical, and environmental specifications of the peripheral housing unit.

Installing the DG/UX™ System (093–701087)

Describes how to install the DG/UX operating system on AViiON 530 and 4600 series hardware.

Setting Up and Installing VMEbus Options in AViiON® Systems (014–001867)

Describes how to jumper VMEbus controllers to operate in an AViiON environment. Explains how to install and remove the controller boards in the system's VMEbus card cage, and supplies instructions for connecting external devices to the controller boards.

Using AViiON® System Diagnostics (014–001863)

Describes how to use menu-based utilities to verify system hardware; test the graphics monitor, keyboard, and mouse; check for faults in LAN connections; and maintain cartridge tape and diskette media.

Reader, Please Note

This manual uses the following terms and conventions:

Within text, “press New Line” means that you should press the New Line key on the Data General DASHER® keyboard. If you are using a keyboard compatible with the industry–standard IBM PC AT® keyboard, the equivalent key is usually marked Enter, Return, or with a symbol such as .

The term *workstation* refers to any single–user AViiON model that provides graphics computing either as a stand–alone station or as a network client to a server system.

The term *server* refers to the computer system that provides user services through direct terminal lines and/or a local area network (LAN). An AViiON server could be a *stand–alone server*, which provides operating system support via direct terminal access, or a *network server*, which provides operating system support to client computers across a local area network. Some computers function as both stand–alone and network servers. The term *client* refers to any computer that receives operating system or file services from a server system across a LAN.

The *system console* refers to the keyboard and display device that receives powerup diagnostic test messages and from which you bring up your operating system. The system console communicates directly with the AViiON 530 or 4600 series computer’s system board. A workstation’s system console consists of the graphics monitor and graphics keyboard. A server’s system console consists of an asynchronous terminal and keyboard.

Within text, we use the following symbols:

Symbol	Means
	Press the New Line, Carriage Return (CR), Return, or Enter key on your system console keyboard.
SCM>	The default System Control Monitor (SCM) prompt.
#	The default DG/UX superuser shell prompt.

In examples we use

This typeface to show your keyboard entry.

This typeface to show system queries and responses.

Contacting Data General

Data General wants to assist you in any way it can to help you use its products. Please feel free to contact the company as outlined below.

Manuals

If you require additional manuals, please use the enclosed TIPS order form (United States only) or contact your local Data General sales representative.

Telephone Assistance

If you are unable to solve a problem using any manual you received with your system, free telephone assistance is available with your hardware warranty and with most Data General software service options. If you are within the United States or Canada, contact the Data General Customer Support Center (CSC) by calling 1-800-DG-HELPS. Lines are open from 8:00 a.m. to 5:00 p.m., your time, Monday through Friday. The center will put you in touch with a member of Data General's telephone assistance staff who can answer your questions.

For telephone assistance outside the United States or Canada, ask your Data General sales representative for the appropriate telephone number.

Joining Our Users Group

Please consider joining the largest independent organization of Data General users, the North American Data General Users Group (NADGUG). In addition to making valuable contacts, members receive *FOCUS* monthly magazine, a conference discount, access to the Software Library and Electronic Bulletin Board, an annual Member Directory, Regional and Special Interest Groups, and much more. For more information about membership in the North American Data General Users Group, call 1-800-253-3902 or 1-508-443-3330.

End of Preface

Contents

Chapter 1 – Getting Started

AViiON 530 and 4600 Series Computers	1-1
Basic System and Options	1-2
About the System Console (AViiON 4600 Series)	1-5
About the Graphics Monitor (AViiON 530 Series)	1-6
About the Keyboard and Mouse (AViiON 530 Series)	1-6
About VMEbus Options	1-7
About Mass–Storage Drives	1-7
Before You Start	1-8
Selecting a Site	1-8
Unpacking and Inspecting Your Equipment	1-9
Gathering Documentation and Media	1-15

Chapter 2 – Setting Up Your Computer System

Connecting the System Console (AViiON 4600 Series)	2-1
Connecting the Graphics Monitor (AViiON 530 Series)	2-3
Connecting the Keyboard (AViiON 530 Series)	2-5
Connecting the Mouse (AViiON 530 Series)	2-6
Connecting a Local Area Network Cable	2-8
Connecting Asynchronous Devices	2-10
Connecting Synchronous Devices	2-12
Connecting a Parallel Printer	2-13
Terminating an Internal SCSI Bus	2-14
Connecting the Computer Unit Power Cord	2-16

Chapter 3 – Starting and Stopping Your Computer System

Starting the Computer System	3-1
Powering Up	3-1
Your Next Step	3-5
Shutting Down Your Computer System	3-8
Powering Down	3-8
Resetting the Computer System	3-9
Restarting Your System	3-10

Chapter 4 – Setting Up and Installing a SCSI Bus

Planning a SCSI Bus Configuration	4-1
Identifying SCSI Drives	4-3
SCSI Bus Cabling Rules	4-6
Configuring Device Operating Parameters	4-7
Terminating the External SCSI Bus	4-7

Installing a SCSI Bus and SCSI Devices	4-10
Installing Configuration Jumpers	4-11
Connecting the SCSI Bus to SCSI devices	4-12
Terminating the SCSI Bus	4-12
Connecting an External SCSI Bus to the Computer Unit Rear Panel	4-13

Chapter 5 – Using the SCM Configuration Menus

Summary of Menus and Menu Conventions	5-1
Changing the Default System Boot Path	5-3
Specifying Boot Devices	5-3
Bootting from Disk or Tape	5-4
Bootting Over a Local Area Network	5-5
Examples of Valid Boot Paths	5-6
Changing Console Parameters	5-8
Changing the System Console Baud Rate	5-9
Changing the System Console Character Length	5-10
Changing the System Console Mode	5-11
Enabling or Disabling Flow Control	5-12
Changing the Keyboard Language	5-12
Changing the Screen–Saver Timeout	5-14
Changing Modem Port Parameters	5-15
Changing the Modem Port Baud Rate	5-16
Changing the Modem Port Character Size	5-17
Changing the Mouse Baud Rate	5-17
Viewing the System Configuration	5-18
Changing the VME A24 Configuration	5-19

Chapter 6 – Expanding and Maintaining Your Computer System

Maintaining Your System	6-1
If a Computer System Problem Occurs	6-2
Reviewing System Specifications	6-2
Verifying Support for Your Configuration	6-2
Calculating Power Requirements	6-3
Avoiding Electrostatic Discharge (ESD) Damage	6-7
Emergency Procedures (without an ESD kit)	6-7
Installing Board Jumpers and Setting Switches	6-8
Installing Jumpers	6-8
Setting Switches	6-9
Opening the Computer Unit	6-10
Removing the Side Covers	6-10
Removing the Top Cover	6-12
Closing the Computer Unit	6-13
Installing the Top Cover	6-13
Installing the Side Covers	6-14

Chapter 7 – Adding or Replacing Internal Mass–Storage Devices

Supported Mass–Storage Devices	7-1
Mass–Storage Device Locations	7-2
Removing a Drive Assembly	7-3
Removing Brackets from a Drive	7-6
Configuring New or Replacement Drives	7-7
Installing a Drive Assembly	7-9
Attaching Brackets to a Drive	7-9
Completing the Drive Assembly Installation	7-10
Adding or Replacing the SCSI Adapter Board	7-14
Removing the SCSI Adapter Board	7-14
Installing the SCSI Adapter Board	7-16
Replacing the Terminator Plug	7-17

Chapter 8 – Adding or Replacing Memory Modules

Rules for Installing Memory Modules	8-2
Removing Memory Modules	8-4
Installing Memory Modules	8-6

Chapter 9 – Adding or Replacing a CPU Complex and System Board Options

Adding or Replacing a CPU Complex Board	9-2
Removing a CPU Complex Board	9-2
Specifying CPU Configurations	9-4
Installing a CPU Complex Board	9-6
Adding or Replacing an I/O Expansion Board	9-7
Removing an I/O Expansion Board	9-8
Installing an I/O Expansion Board	9-11
Adding or Replacing a Graphics or Z–Buffer Board (530 series)	9-15
Removing the Graphics or Z–Buffer Board	9-16
Installing the Graphics or Z–Buffer Board	9-18

Chapter 10 – Replacing the System Board

Removing the System Board	10-1
Installing the System Board	10-5

Chapter 11 – Replacing the Fan Assembly

Removing the Fan Assembly	11-1
Installing the Fan Assembly	11-3

Chapter 12 – Replacing the Power Supply and Fuses

Removing the Power Supply	12-1
Installing the Power Supply	12-4
Replacing the Tape/Disk Fuse	12-7

Appendix A – Technical Specifications

Physical and Environmental Specifications	A-1
System Board and System Bus Options	A-2
VMEbus Backplane and Options	A-3
Mass Storage Options	A-5
Power Subsystem Specifications	A-6
Workstation Peripherals Specifications (AViiON 530 Series)	A-8
Integrated I/O Connectors and Signals	A-11

Appendix B – Using the System Control Monitor

Getting to the SCM	B-1
Using SCM Commands	B-3

Appendix C – Solving Powerup Problems and Exiting the DG/UX Installer

Solving Powerup Problems	C-2
Exiting the Installer System	C-10

Tables

Table

1-1	Voltage Suffixes	1-12
1-2	Cable/Cord Inventory Worksheet	1-14
1-3	Language Suffixes for Keyboard Part Numbers	1-15
4-1	Default SCSI Device ID Numbers	4-3
5-1	Boot Specifications for Disk and Tape Drives	5-5
5-2	Specifications for LAN Devices	5-6
5-3	Alternate Keyboard Codes	5-14
7-1	AViiON 530 and 4600 Series Internal Mass-Storage Drives	7-2
7-2	SCSI Device Identification Numbers	7-8
8-1	Valid Memory Configurations	8-4
A-1	Internal Component Current Requirements for AViiON 530 and 4600 ..	A-7
B-1	SCM Line Editing Features and Keyboard Control Sequences	B-4
B-2	Summary of SCM Commands and Command Functions	B-5
B-3	Mnemonics and Parameters for Bootable Devices	B-8
B-4	Controller (cntrl) Parameter Values	B-9
B-5	Default SCSI Device ID and LUN Numbers	B-10
C-1	Reading Path For Powerup Testing Hangs	C-1
C-2	Quick Reference for Powerup Problems (Graphics Console)	C-3
C-3	Quick Reference for Powerup Problems (Nongraphics Console)	C-4

Figures

Figure

1-1	AViiON 530 Series Computer	1-1
1-2	AViiON 530 and 4600 Series Rear Panel and Connectors	1-5
1-3	Color Graphics Monitor and Controls	1-6
1-4	Removing the Shipping Cover	1-9
1-5	Positioning the Computer Unit Upright	1-10
1-6	Removing the Shipping Tray and Packing Material	1-10
1-7	Removing the Computer from the Packing Tray	1-11
1-8	Voltage Setting Label	1-13
1-9	Installation Checklist	1-16
2-1	Connecting the System Console	2-2
2-2	Graphic Monitor Power Switch	2-4
2-3	Plugging the Cables and Power Cord into the Monitor and Computer Unit	2-4
2-4	Connecting the Color Monitor Power Cord	2-5
2-5	Connecting the Graphics Keyboard	2-6
2-6	Connecting the Mouse	2-7
2-7	Connecting the LAN Transceiver Cable to the Computer Unit	2-9
2-8	Attaching and Securing the LAN Transceiver Cable	2-9
2-9	Connecting Devices to the Computer Unit Serial Ports	2-11
2-10	Connecting a Synchronous Device to the Computer Unit	2-12
2-11	Connecting a Parallel Printer to the Computer Unit	2-13
2-12	AViiON 530 and 4600 Series SCSI Bus Connectors	2-14
2-13	Installing the SCSI Bus Terminator Plug	2-15
2-14	Securing a SCSI Bus Terminator	2-15
2-15	Connecting the Computer Unit Power Cord	2-17
3-1	Monitor Power Switch	3-2
3-2	Peripheral Subsystem Power Switches	3-2
3-3	Computer Unit Power Switch and LED Power-On Indicator	3-3
3-4	Computer Unit Reset and Abort Switch	3-9
4-1	AViiON 530 and 4600 Series SCSI Bus Connectors	4-2
4-2	Sample SCSI Device Identification Configuration	4-5
4-3	Daisy Chain and SCSI Bus Cable Lengths	4-6
4-4	SCSI Bus Configuration Worksheet	4-8
4-5	Sample Configuration Worksheet	4-9
4-6	SCSI Cable Rules and Sample Device IDs	4-10
4-7	AViiON 530 and 4600 Series External SCSI Connectors	4-13
4-8	Removing the SCSI Bus Terminator Plug	4-14
4-9	Plugging Together SCSI Bus Connectors	4-14
4-10	Securing a SCSI Cable Connection	4-14

Figure

5-1	SCM Menus	5-2
5-2	Full Boot Path Format	5-4
6-1	Sample Current and Power Calculation Form	6-5
6-2	Current and Power Calculation Form	6-6
6-3	Removing or Installing Jumper Plugs	6-9
6-4	DIP Switches on Printed-Circuit Boards	6-10
6-5	Loosening the Side Cover Fasteners	6-11
6-6	Removing the Side Covers	6-11
6-7	Attaching the ESD Wrist Strap and Clip	6-12
6-8	Removing the Top Cover	6-13
6-9	Installing the Top Cover	6-14
6-10	Inserting the Cover Tabs into the Computer Unit Slots	6-14
6-11	Installing the Side Covers	6-15
6-12	Tightening the Side Cover Fasteners	6-15
6-13	Connecting the Computer Unit's Power Cord	6-16
7-1	Internal Drive Slots	7-2
7-2	SCSI Bus Ribbon Cable and Device Power Connectors	7-4
7-3	Unplugging the I/O Bus Cable from a Diskette Drive	7-4
7-4	Unplugging the Power Adapter Cable from a Diskette Drive	7-5
7-5	Removing a Drive Assembly from the Computer Unit	7-5
7-6	Removing Brackets from Drives	7-6
7-7	Example of Recommended SCSI ID Settings	7-8
7-8	Bracket Mounting Holes for Drives	7-9
7-9	Attaching Brackets to Drives	7-10
7-10	Removing or Replacing a Filler Panel	7-11
7-11	Installing a Drive Assembly in the Computer Unit	7-12
7-12	Plugging the Power Adapter Cable into a Diskette Drive	7-13
7-13	Plugging the I/O Bus Cable into a Diskette Drive	7-13
7-14	Unplugging the SCSI Bus and I/O Bus Cables from the SCSI Adapter Board	7-14
7-15	Unplugging the Power Adapter Cable from the SCSI Adapter Board	7-15
7-16	Removing or Installing SCSI Adapter Board Screws	7-15
7-17	Plugging the Power Adapter Cable into the SCSI Adapter Board	7-16
7-18	Plugging the SCSI Bus and I/O Bus Cables into the SCSI Adapter Board	7-17
7-19	Unplugging and Plugging in the SCSI Bus Terminator Plug	7-18
8-1	AViiON 530 and 4600 Series ECC Memory Modules	8-1
8-2	Location of Memory Modules and Connectors	8-2
8-3	Numbering Scheme for Memory Module Connectors	8-3
8-4	Releasing the Memory Module Locking Tabs	8-5
8-5	Removing a Memory Module	8-6
8-6	Installing the Memory Module in the Connector	8-7

Figure

9-1	AViiON 530 and 4600 Series System Board Options and CPU Complex ..	9-1
9-2	AViiON 530 and 4600 Series CPU Complexes	9-2
9-3	Removing the CPU Complex Board Screws	9-3
9-4	Separating the Interboard Connectors	9-3
9-5	CPU Configuration Jumpers on the System Board	9-4
9-6	AViiON 530 and 4600 Series CPU Complex Configuration	9-5
9-7	Joining the Interboard Connectors	9-6
9-8	Securing CPU Complex Boards to the System Board	9-7
9-9	I/O Expansion Board Location and Connectors	9-8
9-10	I/O Expansion Board SCSI Ribbon Cable	9-9
9-11	Releasing the I/O Expansion Board from the Computer Bulkhead	9-10
9-12	Separating the Interboard Connectors	9-10
9-13	Removing SCSI B and Second Ethernet Connector Filler Plates	9-12
9-14	Joining the Interboard Connectors	9-12
9-15	Securing the I/O Expansion Board to the Computer Unit Bulkhead	9-13
9-16	Installing the SCSI B Connector	9-14
9-17	Attaching the SCSI B Ribbon Cable to the I/O Expansion Board	9-14
9-18	Location of the Graphics and Z-Buffer Boards on the AViiON 530 Series System Board	9-15
9-19	Releasing the Graphics Monitor Connectors from the Computer Bulkhead	9-16
9-20	Removing the Board-Retaining Screws	9-17
9-21	Separating the Interboard Connectors	9-17
9-22	Removing the Graphics Monitor Connector Filler Plugs	9-18
9-23	Joining the Interboard Connectors	9-19
9-24	Replacing the Board-Retaining Screws	9-20
9-25	Securing Graphics Monitor Connectors to the Computer Bulkhead	9-20
10-1	AViiON 530 and 4600 Series System Board and Mounted Components ..	10-1
10-2	Releasing the System Board Bracket from the Back of the Computer Unit	10-2
10-3	Unplugging Cables from the System Board	10-3
10-4	Unscrewing the System Board from the Computer Unit	10-3
10-5	Releasing the System Board from the VME Backplane	10-4
10-6	Removing the System Board	10-4
10-7	Removing the PROM Component	10-5
10-8	Straightening the Pins on the PROM Component	10-6
10-9	Installing the PROM Component	10-6
10-10	Specifying the CPU Configuration on the System Board	10-7
10-11	AViiON 530 and 4600 Series System Board	10-8
10-12	Inserting the System Board into the Computer Unit	10-9
10-13	Securing the System Board to the Computer Unit	10-9
10-14	Securing the System Board Bracket to the Back of the Computer Unit	10-10
10-15	Plugging Cables into the System Board	10-11

Figure

11-1	Unplugging the Fan Assembly Power Cable from the Power Supply	11-1
11-2	Releasing the Fan Assembly from the Back of the Computer Unit	11-2
11-3	Removing the Fan Assembly from the Computer Unit	11-2
11-4	Positioning the Fan Assembly Under the Computer Unit	11-3
11-5	Installing the Fan Assembly in the Computer Unit	11-4
11-6	Securing the Fan Assembly to the Back of the Computer Unit	11-4
11-7	Plugging the Fan Assembly Power Cable into the Power Supply	11-5
12-1	Unplugging the AC Power and Fan Assembly Power Cables	12-1
12-2	Unplugging the Tape/Disk Power and Logic Power Cables	12-2
12-3	Releasing the Power Supply from the Computer Unit	12-3
12-4	Removing the Power Supply	12-3
12-5	Setting the Voltage Selection Switch	12-4
12-6	Inserting the Power Supply into the Computer Unit	12-5
12-7	Securing the Power Supply to the Computer Unit	12-5
12-8	Connecting the Tape/Disk Power and Logic Power Cables	12-6
12-9	Connecting the Fan Assembly Power and the AC Power Cables	12-6
12-10	Replacing the Tape/Disk Fuse	12-7
A-1	Asynchronous Serial Port (RS232A–C) Connector Signals	A-11
A-2	Asynchronous Cable Signal Routing	A-12
A-3	Synchronous Serial Port Connector Signals	A-12
A-4	Printer Connector (25–Pin)	A-13
A-5	Printer Cable Signal Routing	A-13
A-6	SCSI Connector (50–Pin)	A-14
A-7	LAN Connector (15–Pin)	A-15
A-8	Keyboard Connector and Cable Pin Numbering	A-16
A-9	Mouse DIN Connector and Cable Pin Numbering	A-17
C-1	Monitor Brightness and Degauss Switch	C-7
C-2	Exiting the DG/UX Installation Sequence	C-10

Chapter 1

Getting Started

This chapter provides an overview of basic AViiON® 530 and 4600 series computer systems and hardware options . It also describes what you should do before you begin to set up your system: how to select a site, unpack and inventory your equipment, and gather the appropriate documentation.

AViiON 530 and 4600 Series Computers

AViiON 530 and 4600 series computer systems support a variety of configurations. AViiON 4600 series computers function primarily as the basis of multiuser or server systems; AViiON 530 computers add graphics options to the same basic system to work as graphics workstations. Figure 1–1 illustrates the desktop computer unit the two models hold in common, with the color graphics monitor, IBM PC AT®–style keyboard, and mouse device that distinguish an AViiON 530 series workstation.

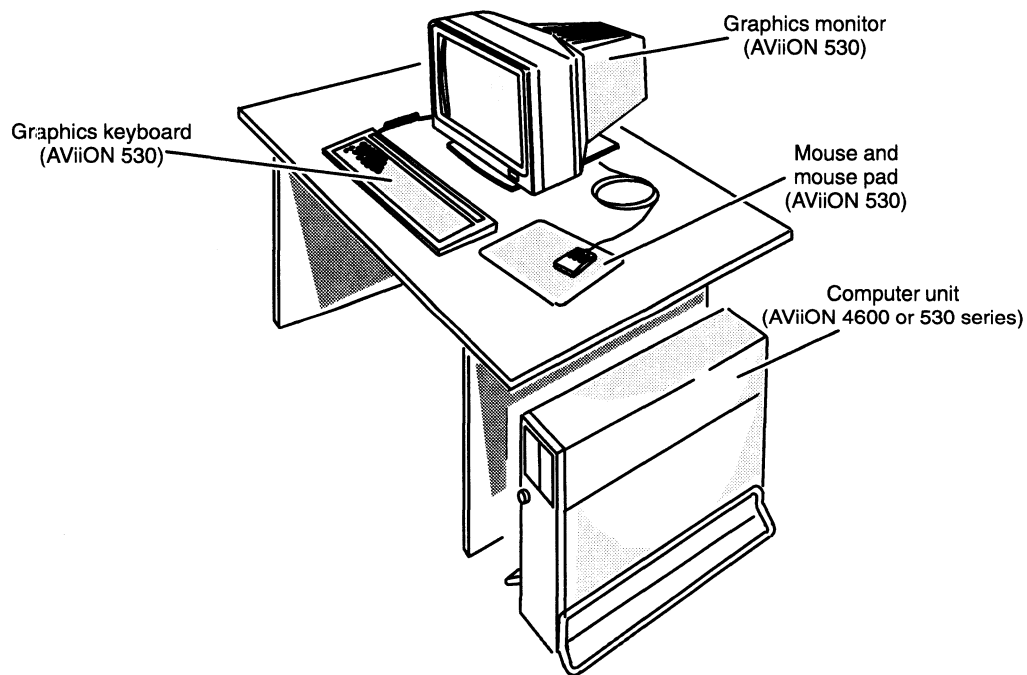

Figure 1–1 AViiON 530 Series Computer

Basic System and Options

All AViiON 4600 and 530 series computer units include the following:

- One system processor (system) board containing
 - Minimum 16 megabytes ECC memory (AViiON 530 series).
 - Minimum 32 megabytes ECC memory (AViiON 4600 series).
 - Three asynchronous RS–232–C ports for a modem or data terminal devices.
 - – Two synchronous RS–232–C ports for synchronous communications.
 - One parallel printer port, compatible with a Centronics LPT1 interface.
 - One integrated AMD Ethernet local area network (LAN) interface compatible with thin or thick Ethernet networks (transceiver not included).
 - One integrated NCR small computer system interface (SCSI) controller for internal (maximum of four) and external (bus maximum of seven) SCSI mass–storage devices.
- One central processing unit (CPU) complex board containing
 - One 33-megahertz Motorola 88100 processor.
 - Two Motorola 88200 Cache/Memory Management Units (CMMUs).
 - (Six 88200 CMMUs per CPU on AViiON 4605 and 4625 systems).
- One 2–slot backpanel printed circuit board with VMEbus
 - (supplies VMEbus to a maximum of two options)
- A 326–watt power supply.

AViiON 530 series systems further include the following:

- One 8–bit or one 24–bit color graphics controller (internal).
- IBM PC AT®–style keyboard
- Mouse
- Color graphics display monitor

NOTE: AViiON 4600 series systems require an asynchronous terminal and keyboard to serve as a system console.

Internal Options

In addition to the basic components listed in the previous section, your system might include some of the following options housed within the computer unit:

System Bus Options

- One additional CPU complex board (must match base system CPU board) ■
- 4-Mbyte or 16-Mbyte ECC single in-line memory modules
 - Maximum of three additional pairs (four pairs total per system)
 - 128 Mbytes system maximum
- One Input/Output (I/O) expansion board (AViiON 4600 series) with
 - One integrated NCR SCSI controller supporting a maximum of seven external SCSI mass-storage devices
 - One integrated AMD Ethernet LAN controller
- One 24-bit Z-buffer board for enhanced graphics performance (AViiON 530 series)

Mass-Storage Devices

Maximum of four (total) of the following:

- Removable media devices (maximum of two)
 - 1/4-inch cartridge (QIC) SCSI tape drives
 - 1.2-Mbyte and 1.44-Mbyte diskette drives
 - 600-Mbyte CD ROM drive
- Winchester hard disk drives (maximum of three half-height or one full-height)
 - 1.4-Gbyte (full-height) ■
 - 1-Gbyte (full-height)
 - 662-Mbyte (full-height)
 - 520-Mbyte (half-height) ■
 - 332-Mbyte (half-height)

VMEbus Option Boards

Maximum of two (total) of the following:

- One or two VAC/16 VME asynchronous controllers
- One VDA/255 VME distributed asynchronous host adapter (AViiON 4600 series)
- One or two VLC VME Ethernet LAN controllers
- One or two VSC/3 VME synchronous controllers
- One or two VTC VME terminal controllers ■
- One or two VTRC VME token ring LAN controllers

External Options

AViiON 530 and 4600 series systems also support the following external devices connected to the rear panel of the desktside computer unit.

- Model 10565 Peripheral Housing Unit (PHU) mass-storage subsystems:
 - Three half-height (1.75-inch) 5.25-inch SCSI devices per PHU
 - One full-height (3.25-inch) 5.25-inch SCSI device per PHU
 - Combination of one full-height and one half-height device per PHU
- CSS2/DC mass storage subsystems:
 - Seven half-height, five full-height, or combination of seven
 - 5.25-inch SCSI devices per CSS2/DC
- Model 6586/6587, Model 6588/6589 reel-to-reel SCSI tape drives
- 3 synchronous devices per VSC/3 controller
- 16 asynchronous devices per VAC/16 controller
- 255 asynchronous devices per VDA/255 adapter (AViiON 4600 series)
 - Controlled by VDC/8P or VDC/16 downloadable cluster controller boxes
- • 255 asynchronous devices per VTC controller (AViiON 4600 series)

Refer to the following sections of this chapter and Appendix A for more detailed information about base and optional system components. Figure 1–2 illustrates the rear panel and connectors to I/O ports for AViiON 530 and 4600 series systems; refer to Chapter 2 for information about installing devices in any of the connectors.

NOTE: For information about connecting devices to VMEbus options, refer to *Setting Up and Installing VMEbus Options in AViiON® Systems*.

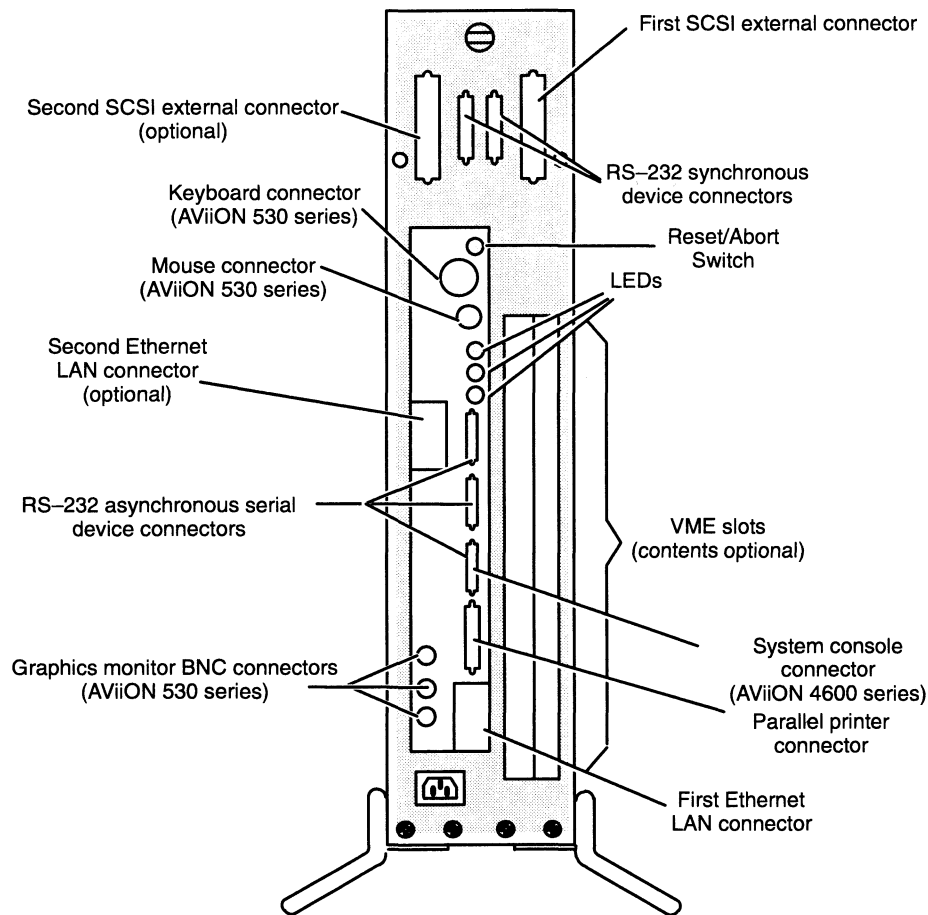

Figure 1-2 AViiON 530 and 4600 Series Rear Panel and Connectors

About the System Console (AViiON 4600 Series)

The term *system console* refers to a terminal, with a keyboard, that receives powerup diagnostic test messages and from which you bring up your operating system.

Any asynchronous terminal with a keyboard, an ASCII character set, and an RS-232-C interface can serve as the system console for AViiON 4600 series computers. However, you need a terminal that conforms to ANSI standard X3.64 (1977) to support a UNIX screen editor. Those terminals that conform to the standard include Data General terminals with ANSI mode, and any terminal that emulates a VT100 or VT220 terminal.

Refer to Chapter 2 for information about connecting the system console to an AViiON 4600 series rear panel connector.

About the Graphics Monitor (AViiON 530 Series)

An AViiON 530 series graphics workstation package includes a Model G6487 color graphics monitor, shown in Figure 1–3. Refer to Chapter 2 for information about connecting your monitor to the computer unit.

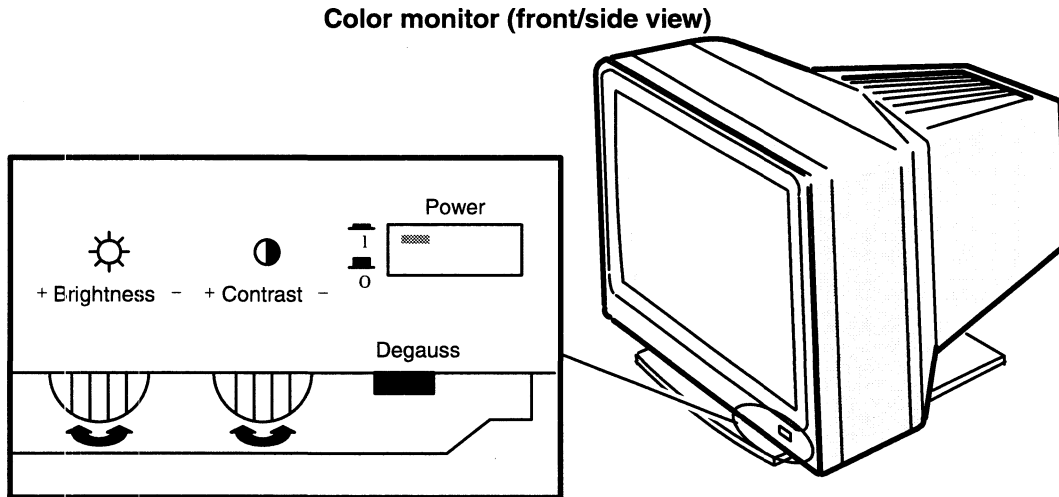

NOTE: Rotate Brightness and Contrast controls left and right to activate. Press Power and Degauss switches *in* to activate. The Power switch LED illuminates when monitor power is on.

Figure 1–3 Color Graphics Monitor and Controls

NOTE: Over time, the monitor screen becomes magnetized and your screen display may appear distorted; pressing the Degauss switch demagnetizes the monitor screen and clears any associated distortion.

If you did not order Data General's Model G6487 graphics monitor, you can use another graphics monitor with the correct video parameters. Refer to Appendix A for required hardware specifications for the monitor.

About the Keyboard and Mouse (AViiON 530 Series)

Your computer system graphics package includes (in addition to the monitor) a keyboard and a three-button optical mouse with pad. Both have optional extension cables for connection to the computer unit. The U.S. English keyboard is compatible with the IBM PC AT–101; some international versions contain 102 keys. The Japanese keyboard is AX-compatible. Refer to Chapter 2 for information about connecting the keyboard and mouse to the desktop computer unit, and to Appendix A for their technical specifications.

About VMEbus Options

The VMEbus backplane printed-circuit board and card cage in an AViiON 530 or 4600 series computer unit can support one or more of the following communications options:

- **VAC/16** — VME Asynchronous Controller that provides as many as 16 ports for asynchronous devices such as user terminals.
- **VSC/3** — VME Synchronous Controller that provides as many as three synchronous communications ports.
- **VDA/255** (AViiON 4600 series) — VME Distributed Asynchronous host adapter that supports as many as 255 asynchronous user devices via a network of cluster controllers.
- **VTC** (AViiON 4600 series) — VME Terminal Controller that supports as many as 255 asynchronous user devices over a standard Ethernet/IEEE 802.3 LAN.
- **VLC** — VME LAN Controller with a connector for a second Ethernet LAN transceiver. Supplements the Ethernet connection managed by the integrated LAN controller(s) on the system board and optional I/O expansion board.
- **VTRC** — VME Token Ring LAN Controller that enables a system to communicate with other computers over an IEEE 802.5 token ring local area network.

About Mass-Storage Drives

The Small Computer System Interface (SCSI) is an ANSI-defined standard for computer and peripheral interconnection. The SCSI bus connector(s) on the computer unit allow you to connect SCSI-based mass-storage devices to your computer system. Each SCSI controller in your system can support as many as seven SCSI drives, including stand-alone drives or drives residing in mass-storage housing units.

Refer to Chapter 4 for information about connecting mass-storage devices using the external SCSI bus connectors on the computer unit rear panel.

Each PHU or CSS2/DC in your system contains a combination of the following 5.25-inch, full-height (3.25-inch) and/or half-height (1.75-inch) SCSI-based drives:

- 662-megabyte, 1-gigabyte, or 1.4-gigabyte Winchester disk drive (FH)
- 332- or 520-megabyte Winchester disk drive (HH; – 520-mbyte drive includes adapter brackets to convert from 3.5- to 5.25-inch width)
- 590-megabyte erasable optical disk drive (FH)
- 2-gigabyte cartridge tape backup (FH)
- 150-megabyte quarter-inch cartridge (QIC) tape drive (HH)
- Multicapacity (320/525-megabyte) QIC tape drive (HH)
- 3.5- or 5.25-inch diskette drive (HH)
- 600-megabyte CD-ROM disk drive (HH)

Refer to the manual that came with the drive and to the manual that came with the mass-storage housing unit for information about adding a drive. These manuals also contain specific information such as environmental specifications, and operating and maintaining procedures.

The following sections describe what you need to do before setting up your new computer system. We suggest that you complete the Installation Checklist (Figure 1-9, at the end of this chapter) before proceeding with any of these installation procedures.

Before You Start

Before setting up your system, you need to prepare a site, unpack and inspect your equipment, confirm that the computer unit voltage is correct for your site, and gather the appropriate documentation and materials.

Selecting a Site

Your first step is to select the final location for setting up and operating your computer system. Try to complete as much of the installation as possible at this final location. Select an area with the following physical requirements:

- Access to at least one ac outlet, plus one outlet for each external peripheral (such as storage units and printers). AViiON 530 series systems also require an outlet for the graphics monitor.
- A desk or cleared work surface to position the external peripherals at a comfortable height for use.

For the AViiON 530 series computer, a desk or cleared work surface to hold the computer unit, graphics monitor, keyboard, mouse with pad, and external peripherals at a comfortable height for use.

- Floor area for the deskside computer unit where it is not likely to be jarred.
- Appropriate natural or electrical lighting.

Make certain that your site is compatible with the physical, environmental, and electrical requirements listed in Appendix A. If you have peripheral devices, examine the documentation that you received with each device for electrical and environmental requirements.

Unpacking and Inspecting Your Equipment

Follow the steps in this section to unpack and inspect your new computer system. Although it may seem simpler to unpack items as you install them, it is important to verify that your equipment arrived as ordered and undamaged before you start.

1. Remove and set aside the packing slip from the outside of each shipping carton; open the cartons one by one and remove the equipment. As you do so, inspect the equipment carefully for visible damage.

CAUTION: Handle your computer equipment carefully; do not drop or jar it. Lift by grasping firm surfaces only.

2. Refer to Figures 1–4 through 1–7 to unpack the computer unit.

NOTE: The computer unit can weigh over 70 pounds. Unpacking the unit involves a vertical lift of approximately six inches, and requires control of the entire unit while it balances at angles approaching forty degrees. While the instructions in Figures 1–4 through 1–7 should enable you to unpack the unit alone, you might want the help of another person.

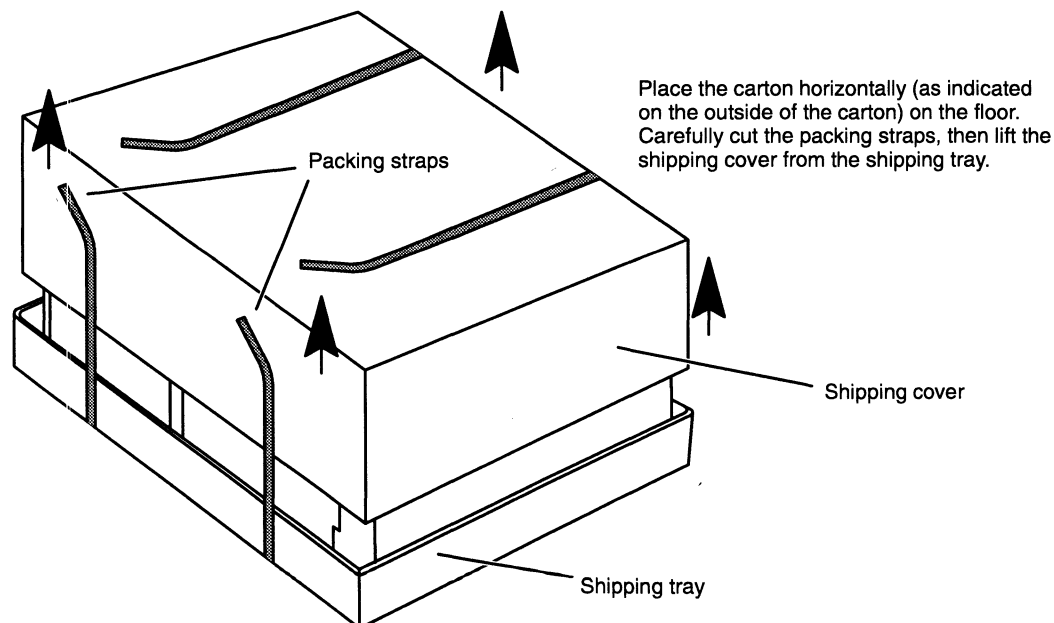

Figure 1–4 Removing the Shipping Cover

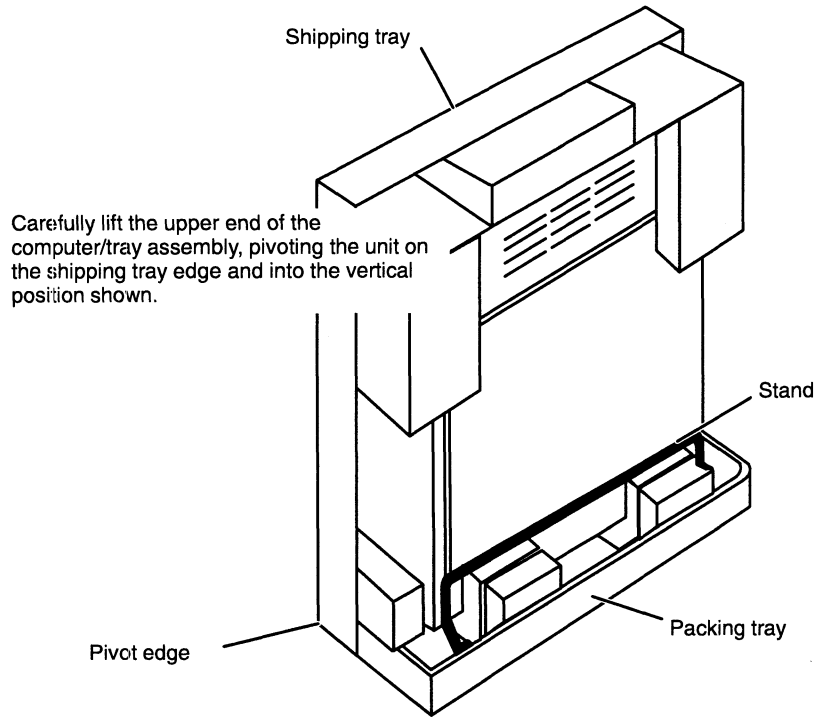

Figure 1-5 Positioning the Computer Unit Upright

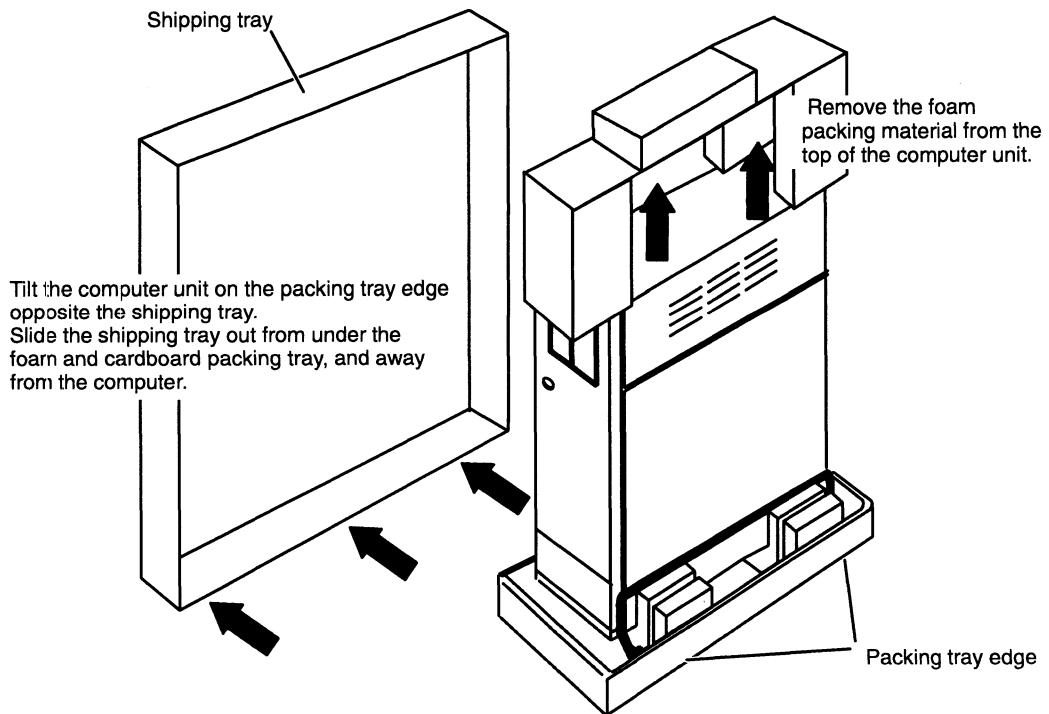

Figure 1-6 Removing the Shipping Tray and Packing Material

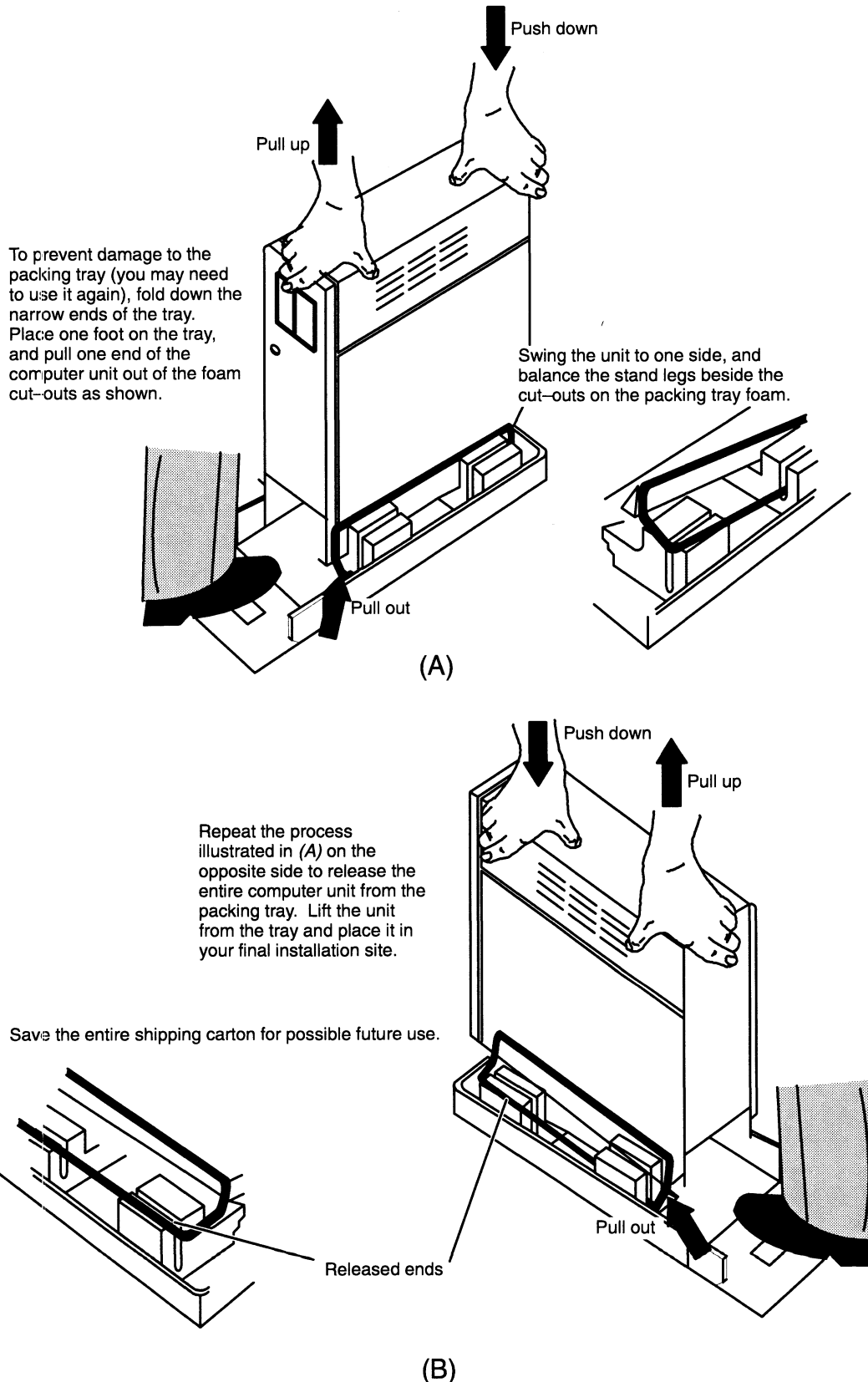

Figure 1-7 Removing the Computer from the Packing Tray

3. Compare the items you received with the items listed on the packing slips. Make sure that the model and/or part numbers on the packing slip match those on your equipment. Open every carton. If you think you received the wrong equipment, contact Data General as described in the Preface.
4. Make sure that you received equipment with the proper voltage and frequency for your site.

You can determine the voltage rating for your power cords (and monitor, for AViiON 530 series computer systems) by examining their model number suffixes. Table 1–1 lists voltage suffixes (by country) for your computer unit power cord and for graphics monitor power cords. Verify that the voltage for both is appropriate for your site.

Table 1–1 Voltage Suffixes

Country	Voltage	Model Number Suffix
U.S./Canada	120	None
U.S./Canada	100	–1
United Kingdom ¹	240	–5
Australia	240	–6
Europe ²	220	–7
Italy	220	–8
Denmark	220	–9
Switzerland	220	–0

¹ Used in Bangladesh, Bermuda, Hong Kong, Nigeria, Pakistan, Singapore, Sri Lanka, and the United Arab Republics.

² Excluding Switzerland, Italy, the United Kingdom, and Denmark.

Verify that the voltage setting for your computer unit power supply is correct for your site. The label shown in Figure 1–8 specifies whether the power supply is set for 100–120 or 200–240 volt operation.

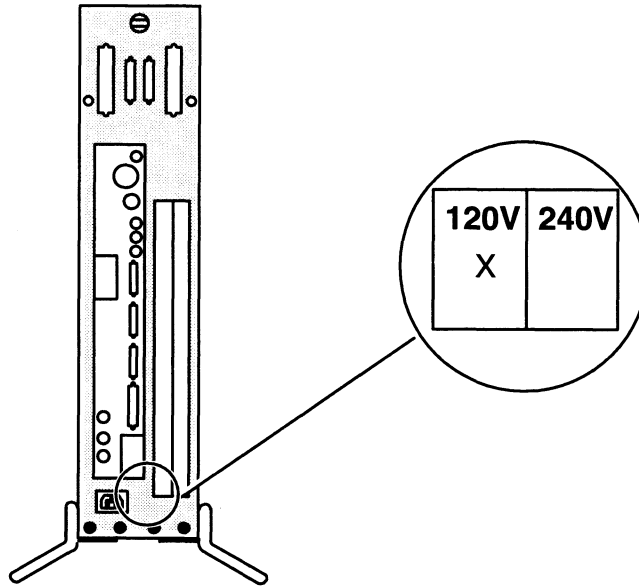

Figure 1-8 Voltage Setting Label

5. Make sure that you have all of the cables listed on your packing slip; the cables may be together in one box or packaged separately with the device. Use Table 1-2 to record the cables you received for integrated system components. (With the exception of the asynchronous adapter cables, you receive only those cables listed in Table 1-2 that were ordered with your computer system.) Refer to *Setting Up and Installing VMEbus Options in AViiON® Systems* to verify the cables for any VMEbus options you received.

Table 1-2 Cable/Cord Inventory Worksheet

<input checked="" type="checkbox"/>	Cable or Cord Type	Part Number	Model Number
	Mouse and Keyboard (AViiON 530 series only)		
<input type="checkbox"/>	5-ft (1.52 m) mouse extension cable	005-008468	15357E005
<input type="checkbox"/>	6-ft (1.83 m) keyboard extension cable	005-008469	15358E006
	Graphics Monitor (AViiON 530 series only)		
<input type="checkbox"/>	Color monitor triple-BNC cable	005-034408	N/A
<input type="checkbox"/>	120-V monitor power cord		109-001253
<input type="checkbox"/>	240-V monitor power cord		109-001544
	Ethernet LAN		
<input type="checkbox"/>	16.4-ft (5 m) IEEE 802.3 plenum	005-033791	1326
<input type="checkbox"/>	65.6-ft (20 m) IEEE 802.3 plenum	005-033787	1326A
<input type="checkbox"/>	16.4-ft (5 m) IEEE 802.3 PVC	005-033766	15274E005
<input type="checkbox"/>	65.6-ft (20 m) IEEE 802.3 PVC	005-031694	15274E020
	External SCSI Mass-Storage		
<input type="checkbox"/>	1.3-ft cable	005-037722	15378E001
<input type="checkbox"/>	3-ft (.91m) cable	005-037725	15378E003
<input type="checkbox"/>	5-ft (1.52 m) cable	005-037723	15378E005
<input type="checkbox"/>	10-ft (3.05 m) cable	005-037724	15378E010
<input type="checkbox"/>	15-ft (4.6 m) cable	005-036625	15378E015
<input type="checkbox"/>	Asynchronous 9- to 25-pin Adapter Cables	005-038420	N/A
	Synchronous Devices		
<input type="checkbox"/>	6-ft (1.83 m) EIA RS-232 cable	005-032917	15290E006
<input type="checkbox"/>	15-ft (4.6 m) EIA RS-232 cable	005-032918	15290E015
<input type="checkbox"/>	25-ft (7.6 m) EIA RS-232 cable	005-032919	15290E025
	Asynchronous Terminals		
<input type="checkbox"/>	10-ft (3.05 m) EIA RS-232 cable	005-034256	15340E010
<input type="checkbox"/>	15-ft (4.6 m) EIA RS-232 cable	005-034990	15340E015
<input type="checkbox"/>	25-ft (7.6 m) EIA RS-232 cable	005-034991	15340E025
	Asynchronous Modems		
<input type="checkbox"/>	10-ft (3.05 m) EIA RS-232 cable	005-036256	15369E010
<input type="checkbox"/>	15-ft (4.6 m) EIA RS-232 cable	005-036257	15369E015
	25-ft (7.6 m) EIA RS-232 cable	005-036258	15369E025
	Parallel Printer		
<input type="checkbox"/>	5-ft (1.5 m) Centronics cable	005-023915	10235
<input type="checkbox"/>	30-ft (9.1 m) Centronics cable	005-033762	15293E030

If you think you received incomplete or incorrect cabling, contact Data General as described in the Preface.

If you are setting up an AViiON 530 series computer system, examine the model number and suffix (the letter following the model number) on the label at the bottom of the keyboard (G6488-x, where x is the the suffix for your keyboard language) to make sure you received the appropriate keyboard. Table 1-3 lists the language suffixes for available keyboards.

Table 1-3 Language Suffixes for Keyboard Part Numbers

Suffix	Keyboard	Suffix	Keyboard
A	U.S. English	I	Italian
B	U.K. English	M	French/Canadian
C	French	N	Swedish/Finnish
D	German	O	Norwegian
G	Spanish	S	Katakana(AX) ¹
H	Danish	Y	Swiss

¹ Japan's AT-compatible keyboard. Supports Katakana and Kanji

If you think you received the wrong keyboard, contact Data General as described in the Preface.

Gathering Documentation and Media

The *Guide to AViiON® and DG/UX™ System Documentation* contains a list and description of all the documentation available for your computer system. The *Installation Roadmap* outlines the path we recommend that you follow through the installation documentation. The Installation Checklist on the following page summarizes the hardware and software installation manuals you may need to set up the computer system and begin software installation.

If you ordered a DG/UX™ operating system package, the files you need to install your operating system are already loaded on the disk, along with AViiON System Diagnostics. Keep the cartridge tapes you received as backup copies of your system software.

Whether or not you ordered the DG/UX operating system, you received AViiON System Diagnostics software on a cartridge tape. You can use these diagnostics to verify your hardware configuration as an optional part of the installation, or use them to test your hardware at a later time. Refer to *Using AViiON® System Diagnostics* for information about using the 15-minute hardware acceptance test and the other diagnostic utilities provided.

Figure 1-9 itemizes what you need to set up and start your computer system for the first time. Your software Release Notices itemize the documentation and media necessary to complete the installation of software packages.

<input checked="" type="checkbox"/>	Check When Completed:
<input type="checkbox"/>	Make sure your installation site satisfies the electrical and environmental requirements listed in Appendix A.
<input type="checkbox"/>	Inspect equipment received for damage.
<input type="checkbox"/>	Compare packing slips with equipment received and equipment ordered.
<input type="checkbox"/>	Determine the ac line current for your site
	<input type="checkbox"/> 100/120 volts
	<input type="checkbox"/> 220/240 volts
<input type="checkbox"/>	Ensure that all of your equipment and cable model numbers reflect the proper site voltage for your site.
<input checked="" type="checkbox"/>	Make Sure You Have These:
<input type="checkbox"/>	Small flat-blade screwdriver (non-magnetic)
<input type="checkbox"/>	Operating system installation documentation. Use <i>Installing the DG/UX™ System</i> to install a basic DG/UX configuration. Most DG/UX installations will also need <i>Customizing the DG/UX™ System</i> .
<input type="checkbox"/>	Software Release Notices, plus cartridge tapes if you did not order preloaded software.
	You May Need These:
<input type="checkbox"/>	<i>Installing and Operating the Model 10565 Peripheral Housing Unit, Installing and Maintaining the CSS2/DC, or Installing the Model 6586/6587 Magnetic Tape Steamer Unit</i> for information about using any of these peripheral options.
<input type="checkbox"/>	<i>Ethernet/IEEE 802.3 Local Area Network Installation Guide</i> for information about installing your integrated LAN(s).
<input type="checkbox"/>	<i>DG/Token Ring Local Area Network Installation Guide</i> for information about installing token-ring network hardware.
<input type="checkbox"/>	<i>Using AViiON® System Diagnostics</i> for information about using the hardware acceptance test or other diagnostic utilities before installing your operating system.
<input type="checkbox"/>	<i>Setting Up and Installing VMEbus Options in AViiON® Systems</i> for information on connecting devices to the VMEbus.
<input type="checkbox"/>	<i>AViiON® Series Systems Automatic Reporting and Remote Assistance User's Guide</i> if your maintenance contract includes this option.

Figure 1-9 Installation Checklist

End of Chapter

Chapter 2

Setting Up Your Computer System

This chapter describes how to connect the computer system console (an asynchronous terminal or a graphics monitor with keyboard and mouse), SCSI bus terminator, and computer unit power cord. It also describes how to connect system options such as a local-area network (LAN) transceiver, a parallel printer, and asynchronous and synchronous devices (serial printers, scanners, plotters, or modems).

NOTE: If your system includes VMEbus distributed controllers, you will need the manual *Setting Up and Installing VMEbus Options in AViiON® Systems* to complete your installation.

Proceed with this chapter to begin your system installation. In many cases, it will describe all the hardware installation procedures you need in order to set up and install your entire system. If your system includes external SCSI-based mass-storage devices, you will need the information in Chapter 4, "Setting Up and Installing a SCSI Bus." For an overview of the computer system hardware components, refer to Chapter 1.

CAUTION: *Do not apply power to the computer unit while setting up your computer system. Refer to Chapter 3 in this manual for powerup instructions.*

Connecting the System Console (AViiON 4600 Series)

Your system console is the keyboard and display device that receives powerup diagnostic test messages from the computer and from which you bring up your operating system. This section describes how to connect an asynchronous terminal to the computer unit rear panel to use as a system console.

NOTE: Any asynchronous terminal with an ANSI-standard character set and an RS-232-C interface can serve as the system console for AViiON 530 and 4600 series computers. However, for full functionality in a UNIX® environment, the terminal has to support the display of the ASCII BS (backspace) character by moving the cursor left one column. Furthermore, you need a terminal that conforms to ANSI standard X3.64 (1977) to support a UNIX-based screen editor. Those terminals that conform to the standard include Data General terminals with ANSI mode, and any terminal that emulates a VT100 or VT220 terminal.

To connect an asynchronous terminal to the system console port of an AViiON 530 or 4600 series system, use the 9- to 25-pin asynchronous adapter cable (female to female), part number 005-38420, and one of the following cables:

Part Number	Model Number	Length (ft.)
005-34256	15340E010	10
005-34990	15340E015	15
005-34991	15340E025	25

To connect a terminal to the system console connector on the computer-unit, complete the following steps.

NOTE: You will need a small flat-head screwdriver to complete these steps.

Refer to Figure 2-1 as you perform the first three steps.

1. Align the holes in the 9-pin end of the asynchronous adapter cable to the pins in the connector labeled "RS232 A" on the computer unit rear panel.

NOTE: Do not use serial ports B or C for the system console.

2. Secure the cable to the connector by tightening the two cable screws with a small flat-head screwdriver.
3. Secure the other (25-pin) end of the adapter cable into one end of the terminal cable.

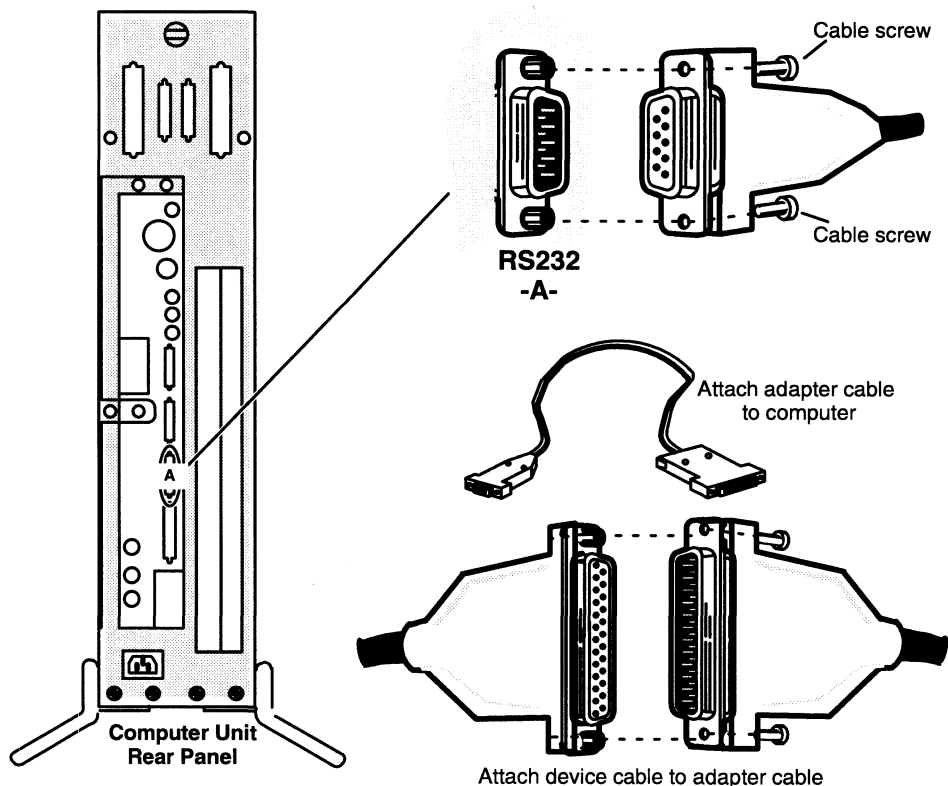

Figure 2-1 Connecting the System Console

4. Secure the other end of the terminal cable to the RS-232 connector on the back of the terminal. Often, the terminal connector is labeled HOST.
5. Initially, both your firmware and the DG/UX operating system require that your system console have the following characteristics:

9600 baud
 8 data bits
 No parity
 ANSI character set
 Enabled flow control

NOTE: If your terminal offers Terminal Configuration menus, use them to further select Unix mode, VT100 emulation, Echo disabled, and New Line disabled.

Set the terminal to select these characteristics. For information on terminal switches and/or menus, see the manual that came with the terminal.

If you have an operating system that supports different terminal characteristics, refer to Chapter 5 for information about changing the console port parameters after your first powerup.

NOTE: SCM menus refer to the port labeled RS232 -A- as the “console port” and to the port labeled RS232 -B- as the “modem port.”

Connecting the Graphics Monitor (AViiON 530 Series)

This section describes how to connect a color graphics monitor to your AViiON 530 series computer unit.

AViiON 530 series systems use the following cables to connect a monitor to the computer unit and to an ac power outlet:

Device	Cable part number	Cable model number
Color monitor (triple BNC)	005-034408	NA
120 volt power cord		109-001253
240 volt power cord		109-001544

1. Place the monitor on top of your work surface. Make sure that the power switches for both the computer unit and the monitor are off, as shown in Figure 2-2.

CAUTION: *The monitor is heavy (approximately 60 pounds); be careful when moving it.*

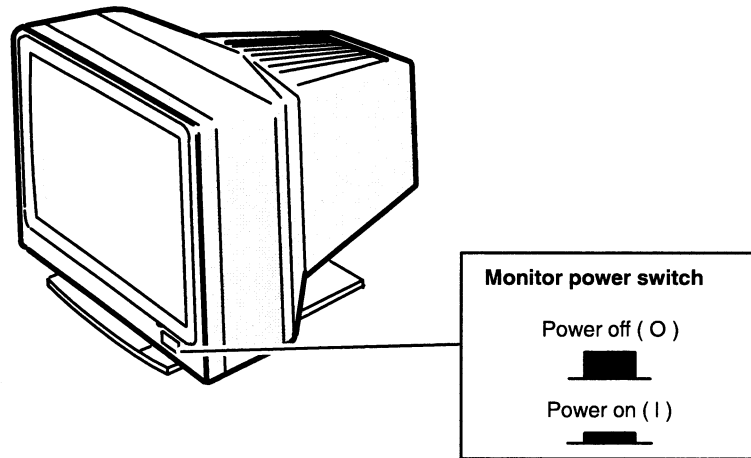

Figure 2-2 Graphic Monitor Power Switch

2. Plug one end of the monitor BNC cable into the connectors on the back of the monitor. The cable is coded with red, green, and blue color strips near the connector ends. Connect the red cable to the R monitor connector, the green cable to the G/MONO connector, and the blue cable to the B connector, as shown in Figure 2-3. Turn the ends of the cables clockwise to lock them in place.

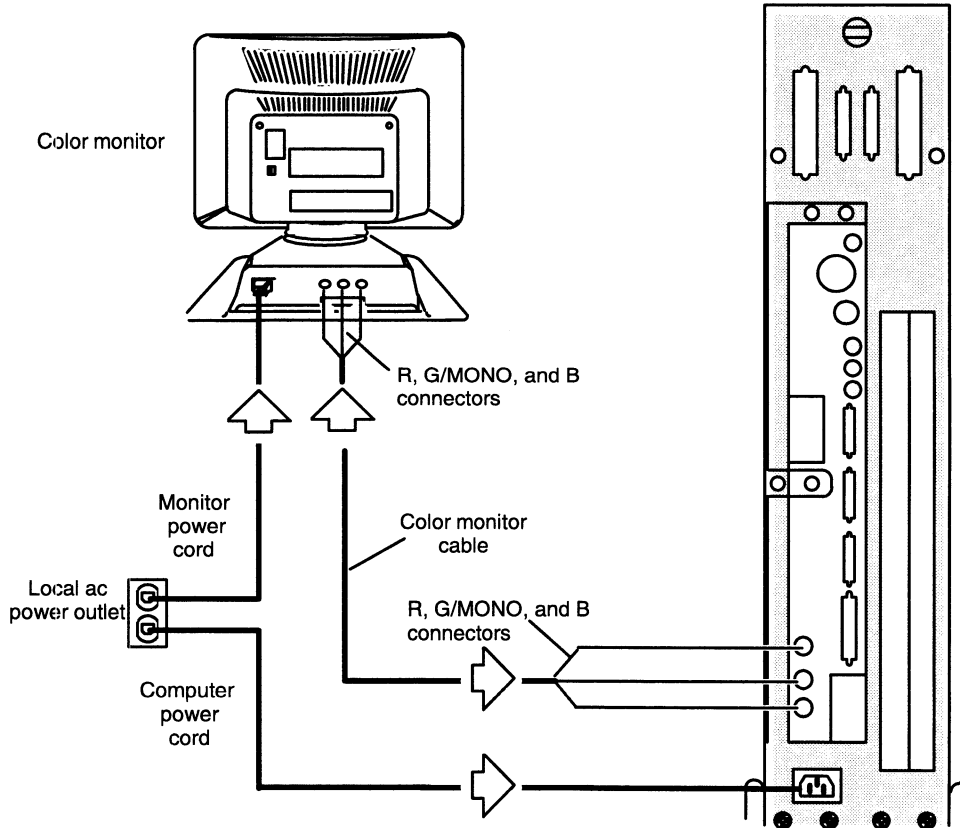

Figure 2-3 Plugging the Cables and Power Cord into the Monitor and Computer Unit

3. Plug the other end of the monitor cable into the connectors on the back of the computer unit. The color monitor cable has color-coded ends which plug into the appropriate R, G/MONO, and B connectors on the back of the computer unit, as shown in Figure 2-3. Turn the ends of the cables clockwise to lock them in place.
4. Plug the female end of the monitor power cord into the ac connector at the back of the monitor. Plug the male end of the monitor power cord into an ac outlet. Figure 2-4 illustrates how to connect the monitor cord.

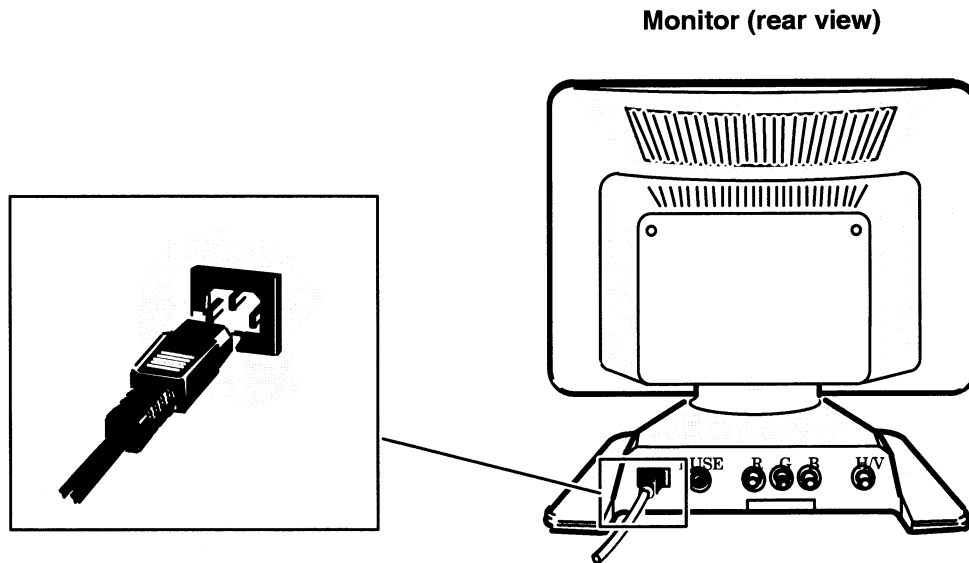

Figure 2-4 Connecting the Color Monitor Power Cord

Connecting the Keyboard (AViiON 530 Series)

Follow these steps to connect the keyboard to the computer unit. Reverse the order of these instructions to remove a faulty keyboard in order to replace it.

CAUTION: Do not try to remove or replace your keyboard while the computer power is on.

AViiON 530 series systems use the following extension cable to connect the keyboard cable to the computer unit:

Cable	part number	model number	length (ft.)
Keyboard (extension)	005-08469	1538E006	6

1. Position the computer unit so that you have access to the rear panel connectors.
2. Place the keyboard on the work surface.

3. Attach the female end of the keyboard extension cable to the end of the keyboard cable; then, plug the other end of the extended keyboard cable into the keyboard connector on the rear panel of the computer unit, as shown in Figure 2-5.

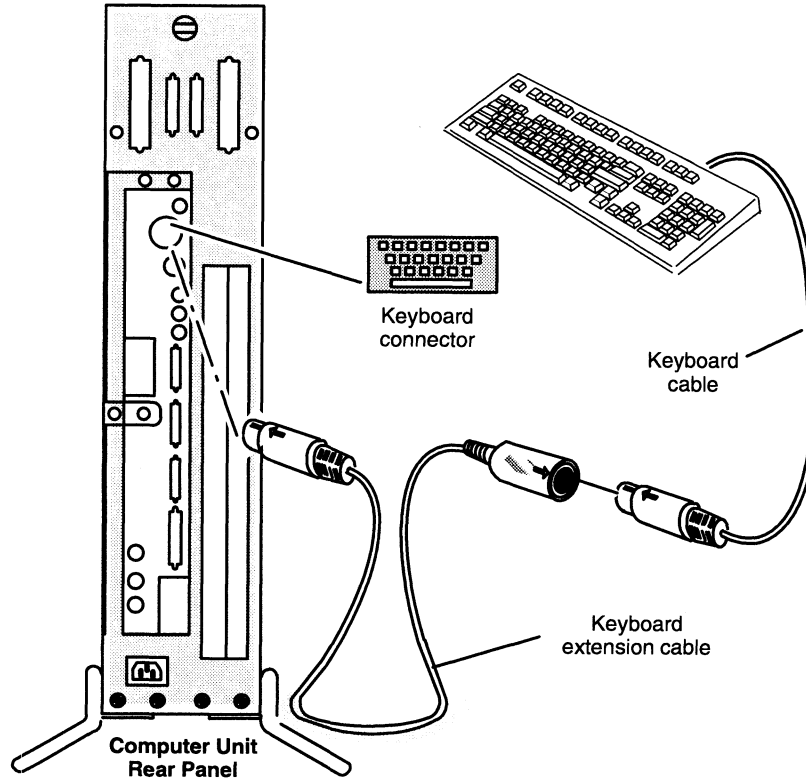

Figure 2-5 Connecting the Graphics Keyboard

Connecting the Mouse (AViiON 530 Series)

Follow these steps to connect the mouse device to the computer unit. Reverse the order of these instructions to remove a faulty mouse in order to replace it.

CAUTION: Do not try to remove or replace your mouse while computer power is on.

AViiON 530 series systems use the following extension cable to connect the mouse cable to the computer unit:

Cable	part number	model number	length (ft.)
Mouse (extension)	005-08468	1537E005	5

1. Position the computer unit so that you have access to the rear panel connectors.
2. Place the mouse and pad on the work surface. Position the mouse pad so that its longer side aligns with the edge of the work surface and place the mouse on the mouse pad.

NOTE: For right-handed use, position the mouse pad just to the right of the keyboard; place it to the left for left-handed use.

3. Attach the female end of the mouse extension cable to the end of the mouse cable; then plug the other end of the extended mouse cable into the rear panel of the computer unit, as shown in Figure 2-6.

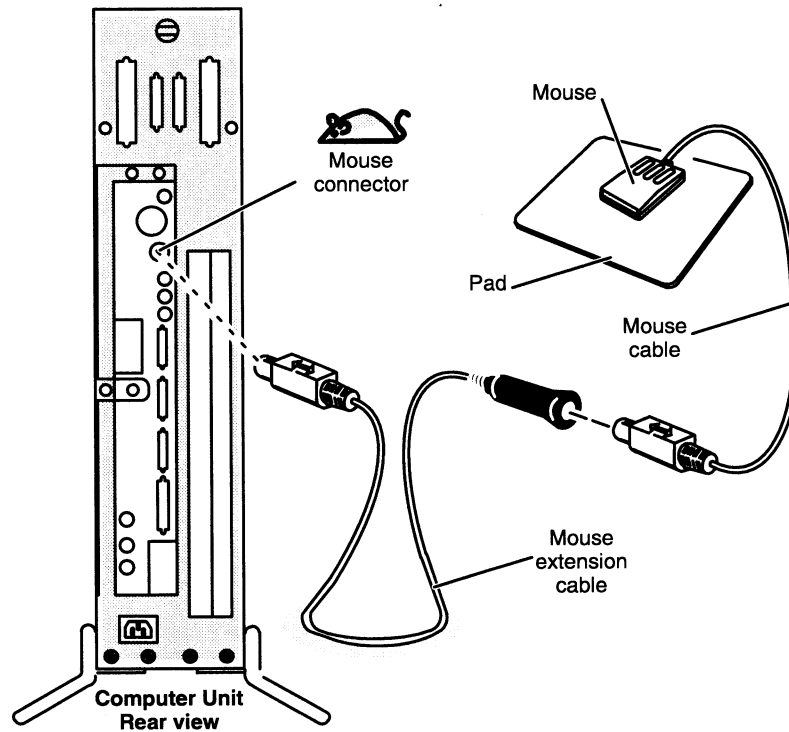

Figure 2-6 Connecting the Mouse

Connecting a Local Area Network Cable

If your computer system will be part of an Ethernet local area network (LAN), you must connect the LAN transceiver cable to the computer unit LAN connector. The steps in this section assume that the LAN drop cable is already installed and the male end of the cable is within reach of your computer unit. Refer to the manual *Ethernet/IEEE 802.3 Local Area Network Installation Guide* (listed in the Preface) for detailed information about installing your Ethernet network.

NOTE: Your AViiON 530 or 4600 series system may include optional VLC, VTC, or VTTC controllers installed in the rear panel VME card cage. Refer to *Setting Up and Installing VMEbus Options in AViiON® Systems* for information about installing VMEbus options.

AViiON 530 or 4600 series systems use the following cables to connect an integrated Ethernet LAN to the rear panel connector(s):

Cable type	Cable		length (ft.)
	part number	model number	
Plenum (Teflon®)	005-33791	1326	16.4
	005-33787	1326A	65.6
PVC	005-33766	15274E005	16.4
	005-31694	15274E020	65.6

To connect a LAN transceiver cable to the computer unit LAN connector, complete the following steps. You will need a flat-blade screwdriver or comparable tool to complete these steps. Reverse the order of these steps to remove a faulty LAN cable in order to replace it.

NOTE: An optional screw converter kit (part number 005-37438) enables you to remove the sliding lock assembly described in these steps and use screw mounts to secure your LAN cable. If you received this option, refer to the instructions that came with the screw converter kit.

1. Align the holes in the transceiver cable with the pins in the computer unit LAN connector, shown in Figure 2-7.

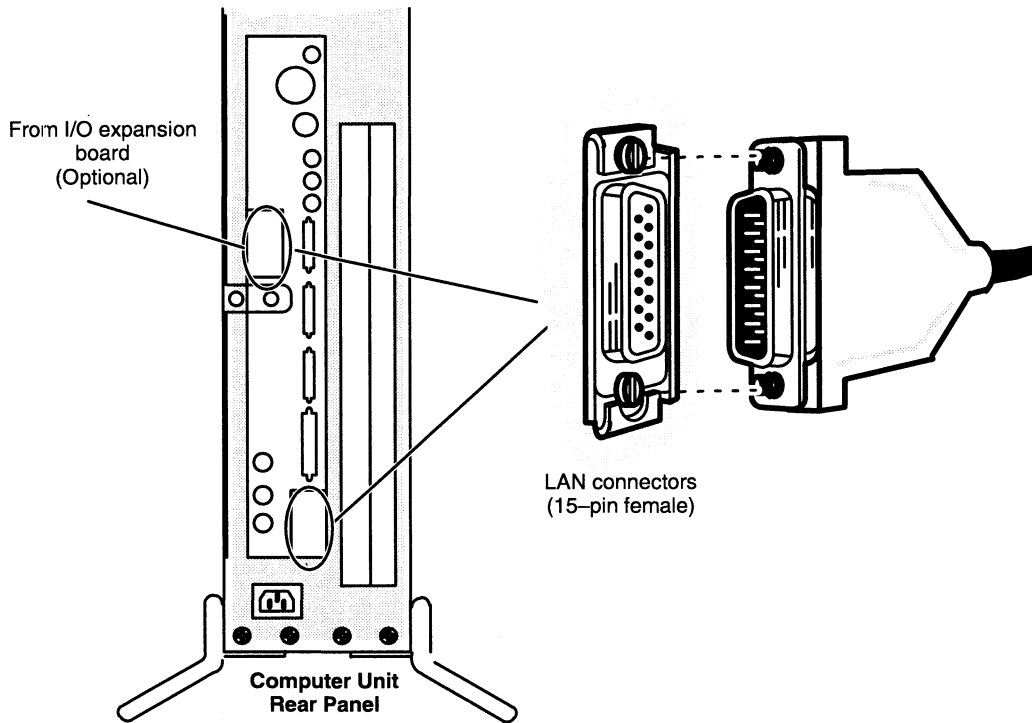

Figure 2-7 Connecting the LAN Transceiver Cable to the Computer Unit

2. As shown in Figure 2-8(A) and (B), line up the slide clip on the computer unit connector so that the slide clip mounts on the cable can pass through; then push the cable firmly into the connector.
3. Once the cable and clip mounts are secured to the connector, slide the clip using your screwdriver or a comparable tool to lock the cable in place, as shown in Figure 2-8(C).

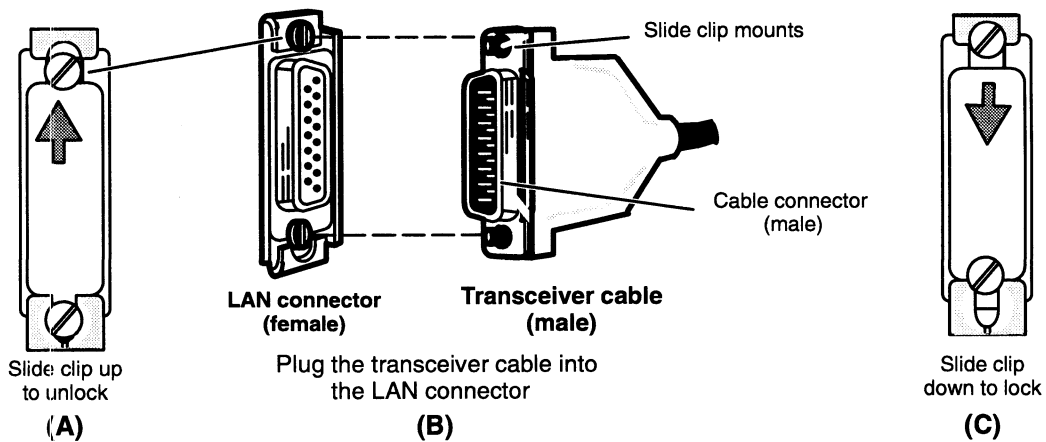

Figure 2-8 Attaching and Securing the LAN Transceiver Cable

Connecting Asynchronous Devices

This section describes how to connect an asynchronous device such as a display terminal, modem, scanner, plotter, or printer to any of the three serial port connectors on the computer unit rear panel.

AViiON 530 or 4600 series systems require a 9- to 25-pin (female-female) asynchronous adapter cable (part number 00538420) to connect asynchronous serial devices to the rear panel connectors. In addition to the adapter cable, each connection requires one of the device cables listed below.

Device	Cable part number	Cable model number	Cable length (ft.)
Terminal or system console	005-34256	15340E010	10
	005-34990	15340E015	15
	005-34991	15340E025	25
Modem	005-36256	15369E010	10
	005-36257	15369E015	15
	005-36258	15369E025	25

Complete the following steps to connect an asynchronous device to your computer system. Reverse these steps to remove or replace an asynchronous device. You will need a nonmagnetic, small flat-blade screwdriver or similar tool to complete these steps. Refer to Figure 2-9 as you perform the first three steps.

1. Plug the 9-pin female end of the asynchronous adapter cable into one of the three male connectors on the back of the computer unit. The connectors are labeled RS232 -A-, RS232 -B-, and RS232-C. Use the RS232 -A- port for the system console.

NOTE: If an asynchronous terminal will serve as a workstation system console instead of a graphics monitor, you must connect the terminal to the RS232 -A- port and disconnect the graphics keyboard from its computer unit connector.

Devices requiring Data Carrier Detect (DCD) signal transmission further require installation of a DCD enabling jumper on the system board. On systems running the DG/UX™ operating system, such devices include all terminals. DCD to the system console serial port connector marked RS232 -A- is factory-enabled; to operate another terminal connected to the B or C ports, you must install an enabling jumper as shown in Figure 10-11.

2. Secure the adapter cable to the connector by aligning and then tightening the two screws on the cable.
3. Plug the other end of the adapter cable into the terminal, modem or printer cable you intend to use.

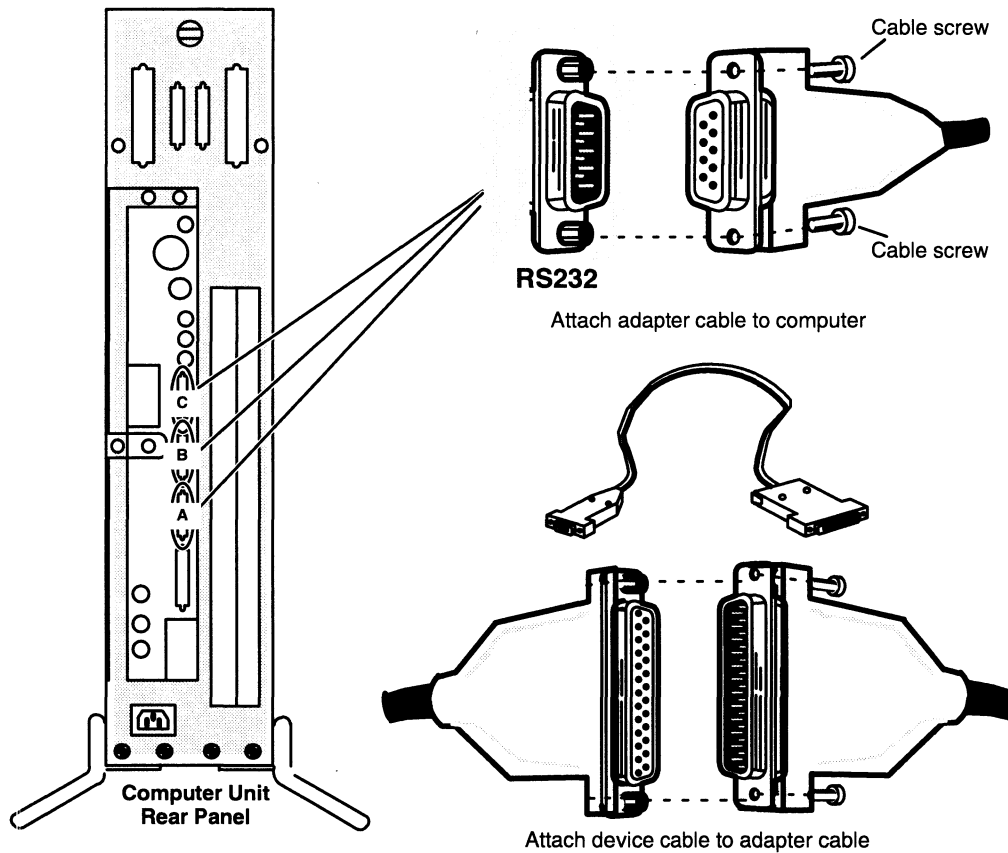

Figure 2-9 Connecting Devices to the Computer Unit Serial Ports

4. Connect the device cable to the RS-232 connector on the back of the terminal, modem, or printer and secure the cable connection.
5. Set the switches on the terminal, modem, or printer to select the appropriate characteristics. Initially, both your firmware and the DG/UX operating system require that the devices connected to ports "RS232 -A-," "RS232 -B-," and "RS232-C" have the following characteristics:

9600 baud 8 data bits
 No parity ANSI character set
 Enabled flow control

NOTE: These default settings are applied to all three asynchronous ports prior to shipment.

Set the switches on the device to select these characteristics. For information on device switches, see the manual that came with the device.

If you need to change these default characteristics, refer to Chapter 5 for information about changing the configuration parameters after your first powerup. SCM menus refer to the serial port labeled RS232 -A- as the "console port" and to the port labeled RS232 -B- as the "modem port." For information on defining characteristics for port RS232-C, refer to *Customizing the DG/UX™ Operating System*.

Connecting Synchronous Devices

This section describes how to connect synchronous devices such as modems to either of the two synchronous communications ports on the computer unit rear panel. Reverse the order of these steps to remove or replace the synchronous device.

AViiON 530 or 4600 series systems use the following 25-pin D male-to-male cables to connect a synchronous modem to the rear panel connectors:

Device	Cable part number	Cable model number	Cable length (ft.)
Synchronous modem	005-032917	15290E006	6
	005-032918	15290E015	15
	005-032919	15290E025	25

1. Plug one end of the synchronous communication cable into the COM A or COM B connector on the back of the computer unit as shown in Figure 2-10. Attach the cable to the connector by tightening the two screws on the cable.

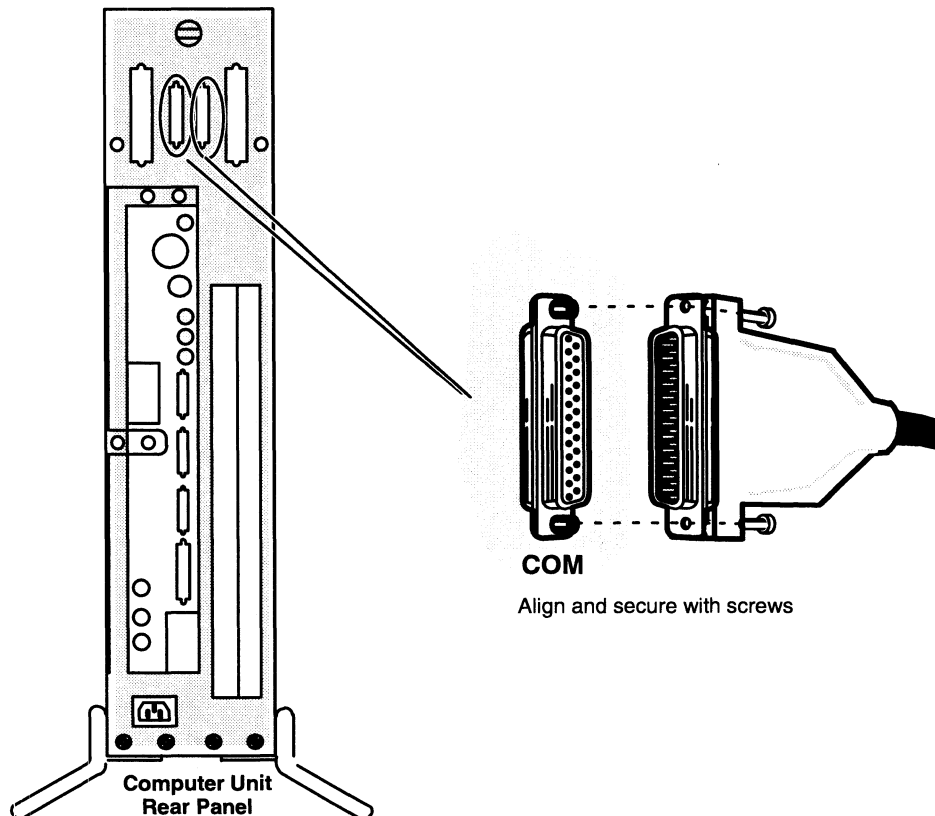

Figure 2-10 Connecting a Synchronous Device to the Computer Unit

2. Plug the other end of the cable into the connector on the synchronous device. See the documentation that came with the device for further instructions.
NOTE: To further set up your device to operate under the DG/UX operating system, refer to *Customizing the DG/UX™ System*.

Connecting a Parallel Printer

This section describes how to connect a parallel printer with a Centronics LPT1 interface. Reverse the order of these steps to remove or replace the printer cable.

AViiON 530 and 4600 series systems use the following 25-pin to 36-position cables to connect a parallel printer to the rear panel connector:

Device	Cable part number	Cable model number	Cable length (ft.)
Parallel printer	005-023915	10235	5
(Centronics LPT1 interface)	005-033762	15293E030	30

1. Plug the 25-pin end of the printer cable into the parallel printer connector on the back of the computer unit as shown in Figure 2-11. Attach the printer cable to the connector by tightening the two screws on the printer cable.

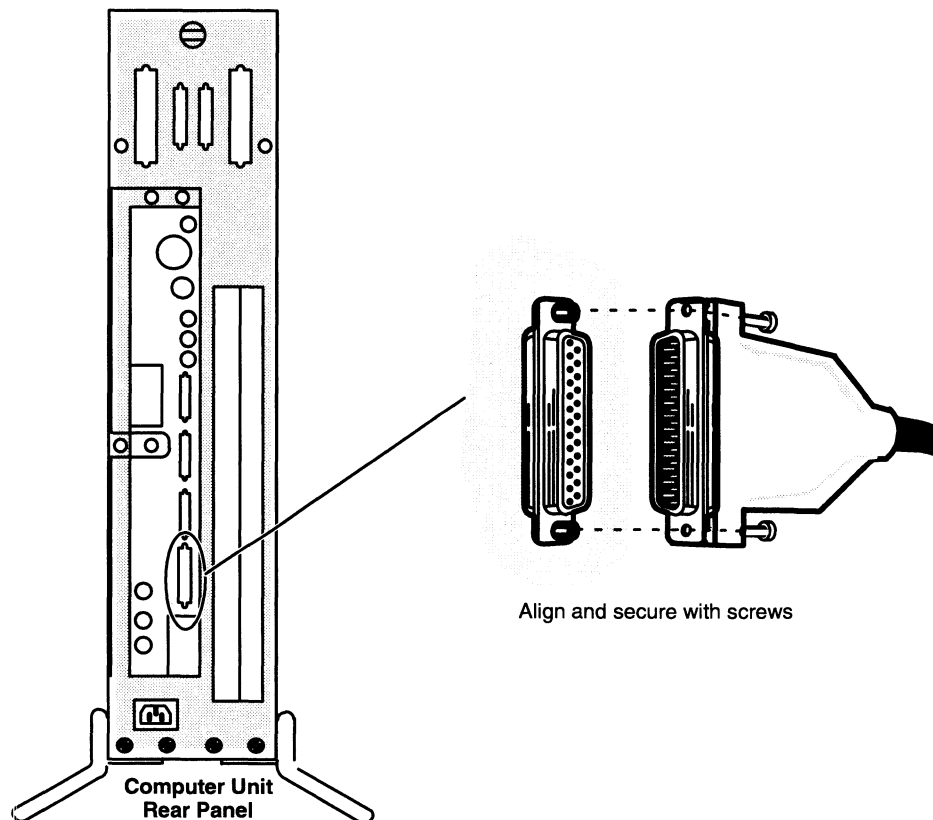

Figure 2-11 Connecting a Parallel Printer to the Computer Unit

2. Plug the other (36-position CHAMP) end of the printer cable into the connector on the parallel printer. See the documentation that came with the printer for further instructions.

NOTE: To further set up your printer to operate under the DG/UX operating system, refer to *Customizing the DG/UX™ System*.

Terminating an Internal SCSI Bus

If your system does not include any *external* mass-storage subsystems or devices, you must terminate the bus that links the Small Computer System Interface (SCSI) controller, your internal SCSI devices, and the SCSI A rear panel connector. Your tape and disk drives will not operate correctly until the SCSI A bus is properly terminated. If your computer includes an I/O expansion card, the slot labeled SCSI B will also contain a SCSI connector. If you do not plan to use this connector for external subsystems or drives, you must also terminate the SCSI B bus.

NOTE: In most cases, your computer unit is shipped with the SCSI bus terminator(s) already installed. If a large black plug occupies the rear panel connector(s) labeled SCSI, and you have no external SCSI devices, you can skip this section and continue with the next section, “Connecting the Computer Unit Power Cord.”

If your system *includes* external SCSI devices (any disk, tape, diskette, CD-ROM, or optical disk drive housed outside the computer unit), skip this section and refer to Chapter 4, “Setting Up and Installing a SCSI Bus.” When you finish setting up and installing your external SCSI bus, return to the last section in this chapter, “Connecting the Computer Unit Power Cord.”

To terminate an internal SCSI bus, follow these steps.

1. Locate the CHAMP terminator plug, Data General number 005033334, and the SCSI rear panel connector shown in Figure 2-12.

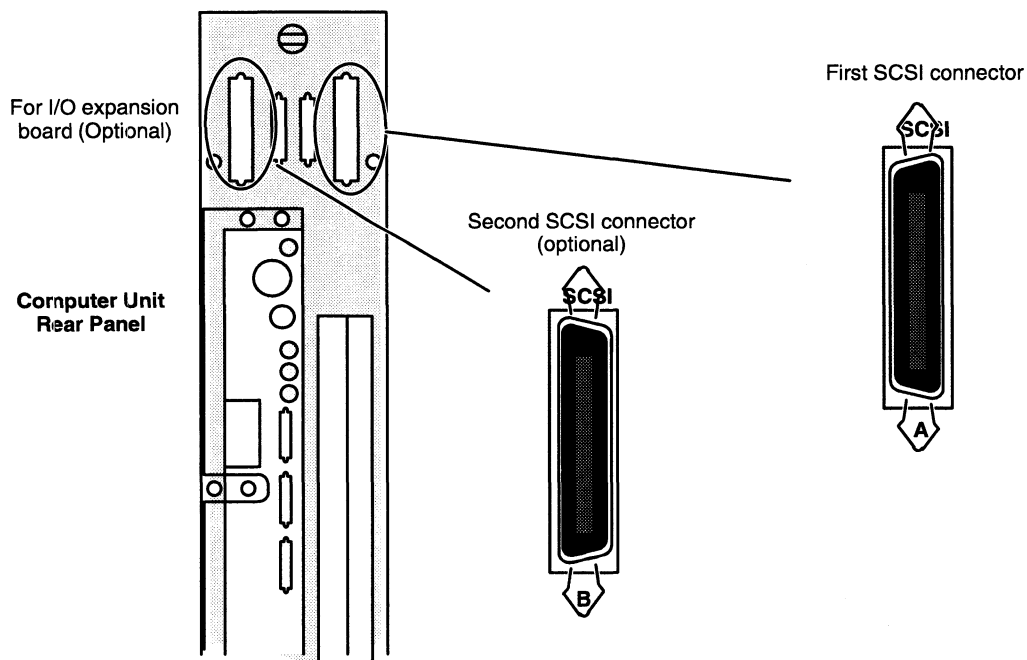

Figure 2-12 AViiON 530 and 4600 Series SCSI Bus Connectors

- Align the connector pin numbers and the D-shaped connector bevels before gently inserting the plug in the SCSI connector, as shown in Figure 2-13.

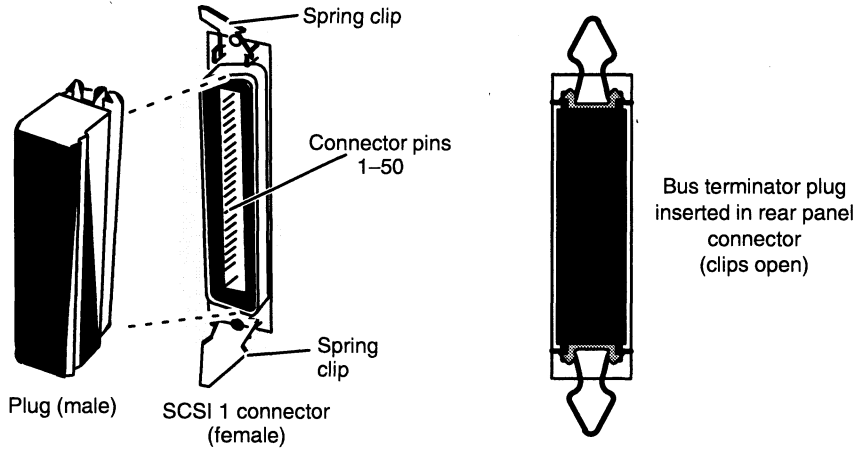

Figure 2-13 Installing the SCSI Bus Terminator Plug

- Push the spring clips attached to the SCSI connector straight down or straight up into the brackets on the terminator plug, as shown in Figure 2-14. Your vertical pressure will push the clips into place; do not squeeze or pull the clips out of shape.
- Push the spring clips attached to the SCSI 1 connector straight down or straight up into the brackets on the terminator plug, as shown in Figure 2-14. Your vertical pressure will push the clips into place; do not squeeze or pull the clips out of shape.

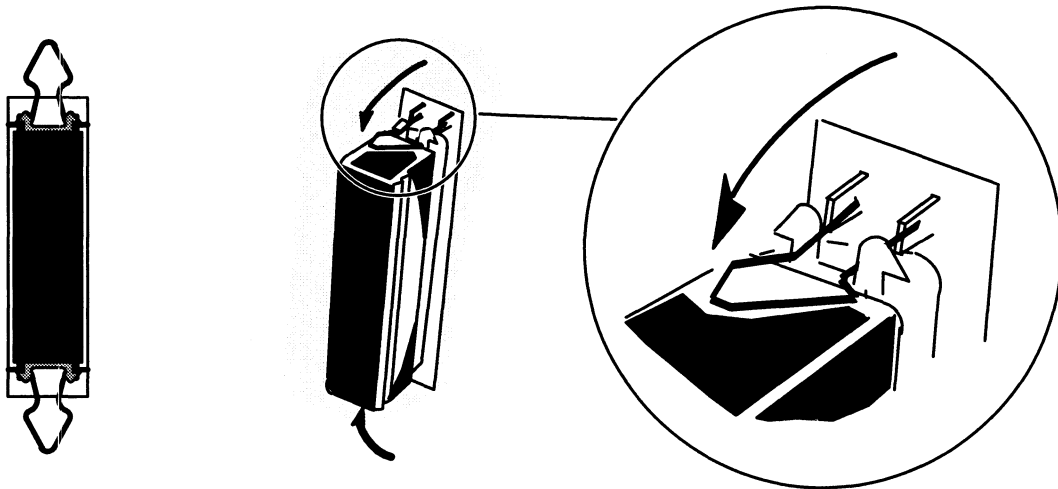

Figure 2-14 Securing a SCSI Bus Terminator

NOTE: To remove a terminator, simply reverse the process illustrated above; pull the clips vertically and gently pull the terminator out of the rear panel connector.

Connecting the Computer Unit Power Cord

After you have assembled your computer system, use these steps to connect the computer unit power cord to an ac outlet and complete your set-up procedures. Reverse the order of these steps to disconnect the computer unit power cord.

CAUTION: *Make sure that the computer unit power switch is off before connecting the power cord.*

1. Locate the computer unit power cord. The correct power cord part number ensures that you are using a proper cord for your site's voltage. AViiON 530 and 4600 series computers use the following power cords:

Cord	part number	model number	Country
120 volt	109-996		US
100 volt	109-996	-1	US/Canada
240 volt	109-813	-5	UK ¹
240 volt	109-809	-6	Australia
220 volt	109-812	-7	Europe ²
220 volt	109-811	-8	Italy
220 volt	109-815	-9	Denmark
220 volt	109-810	-0	Switzerland

¹ Used in Bangladesh, Bermuda, Hong Kong, Nigeria, Pakistan, Singapore, Sri Lanka, and the United Arab Republics.

² Excluding Italy, Switzerland, the United Kingdom, and Denmark.

2. The computer unit is shipped with a yellow and black warning label covering the rear panel ac connector. Examine the computer unit's device rating label to be sure your computer unit's voltage is properly set for your site. If the label indicates proper voltage, remove the warning label and plug the female end of the computer unit power cord into the ac connector as shown in Figure 2-15.

WARNING: **Do not attempt to connect or power up your machine if it is not compatible with your ac power source. If the warning label does not indicate the proper voltage selection for your site, contact Data General before continuing.**

3. Plug the male end of the computer unit power cord into an ac outlet.

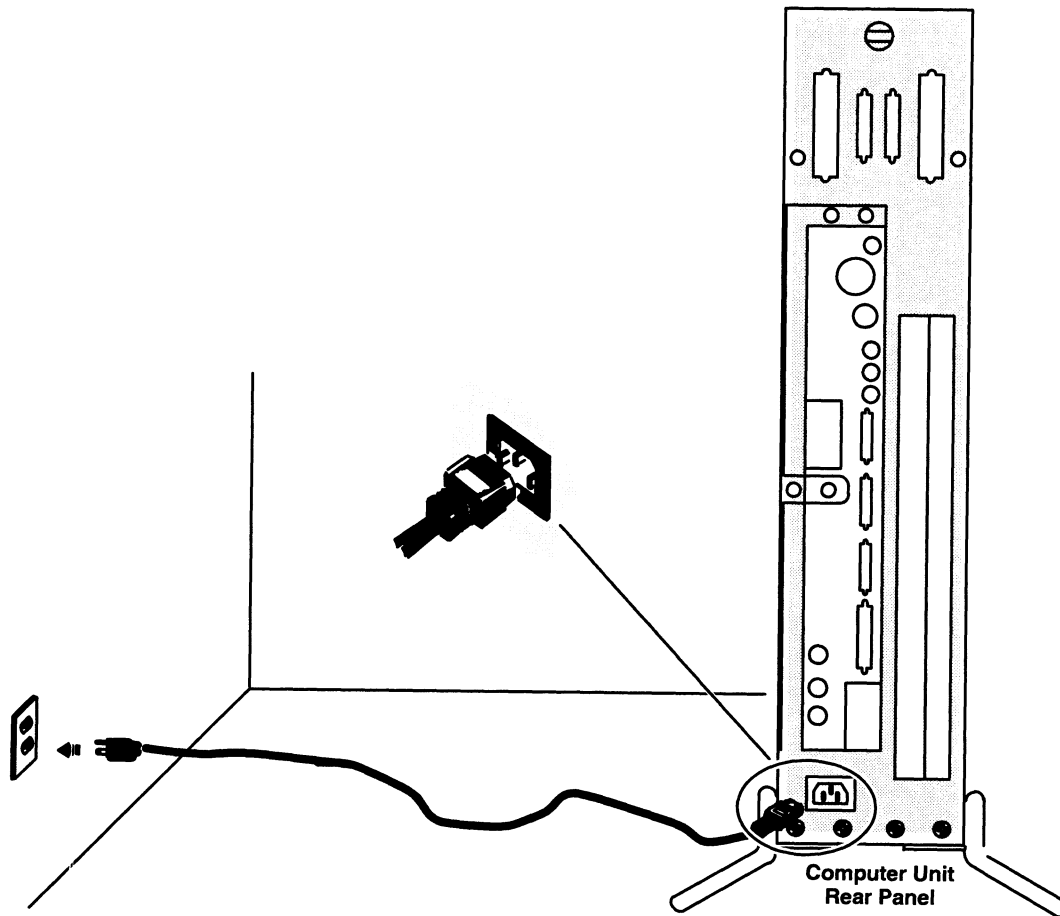

Figure 2-15 Connecting the Computer Unit Power Cord

Now that you have set up the computer system hardware, continue with the steps in Chapter 3 to ensure that the computer system starts properly, to become familiar with powerup procedures, and to verify that the computer system hardware passes all powerup diagnostic tests. When you complete the procedures described in Chapter 3, you can install your operating system and application software.

End of Chapter

Chapter 3

Starting and Stopping Your Computer System

The first section of this chapter describes a normal powerup sequence. After you install your computer system hardware (for the first time, as described in Chapter 2, or after hardware maintenance, as described in Chapter 6), follow the steps in the “Powering Up” section of this chapter to start the computer and boot your operating system. The last section of this chapter explains how to properly power down, reset and restart the computer system.

Starting the Computer System

Each time you apply ac power to your computer system, a series of diagnostic tests in the firmware verify that the hardware is functioning well enough to run your operating system and its applications. Appendix C, “Solving Powerup Problems and Exiting the DG/UX Installer,” describes what you can do if your computer system fails to successfully complete powerup diagnostic tests. The following sections of this chapter describe how to power up your system, and describe what you should do the first time you start up your AViiON 530 or 4600 series computer.

Once you install and customize your operating system, the sequence of events and displays you see after powerup testing will change; refer to your operating system documentation for information on booting installed and customized software.

NOTE: We strongly recommend that you familiarize yourself with your operating system installation procedures and documentation *before* you power up for the first time. You should also determine whether you want to run hardware diagnostics before installing your operating system, and whether you need to alter any hardware configuration parameters from the defaults listed in Chapter 2.

Powering Up

This section describes how to power up your computer system. It is important that you turn power on to the computer unit and peripherals in the proper sequence, and that your computer system completes the powerup testing properly.

CAUTION: *Verify that the computer unit, monitor, peripherals, and all power cords have appropriate ac power voltage for your site before turning on power to your computer system, as described in Chapter 2.*

1. Turn on power to the system console. For graphics workstations, turn on power to the display monitor, as shown in Figure 3-1.

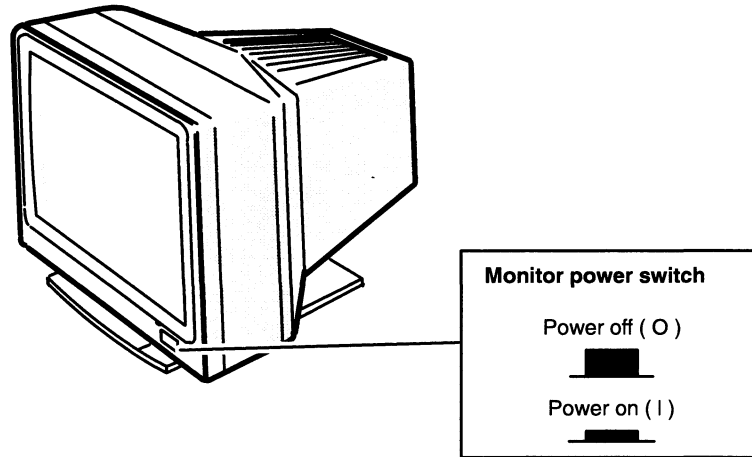

Figure 3-1 Monitor Power Switch

2. If you have a Peripheral Housing Unit (PHU), a combined storage subsystem (CSS2/DC), or another external peripheral unit connected to your computer system, turn on power to that device. Figure 3-2 shows how to turn on power to a PHU or CSS2/DC.

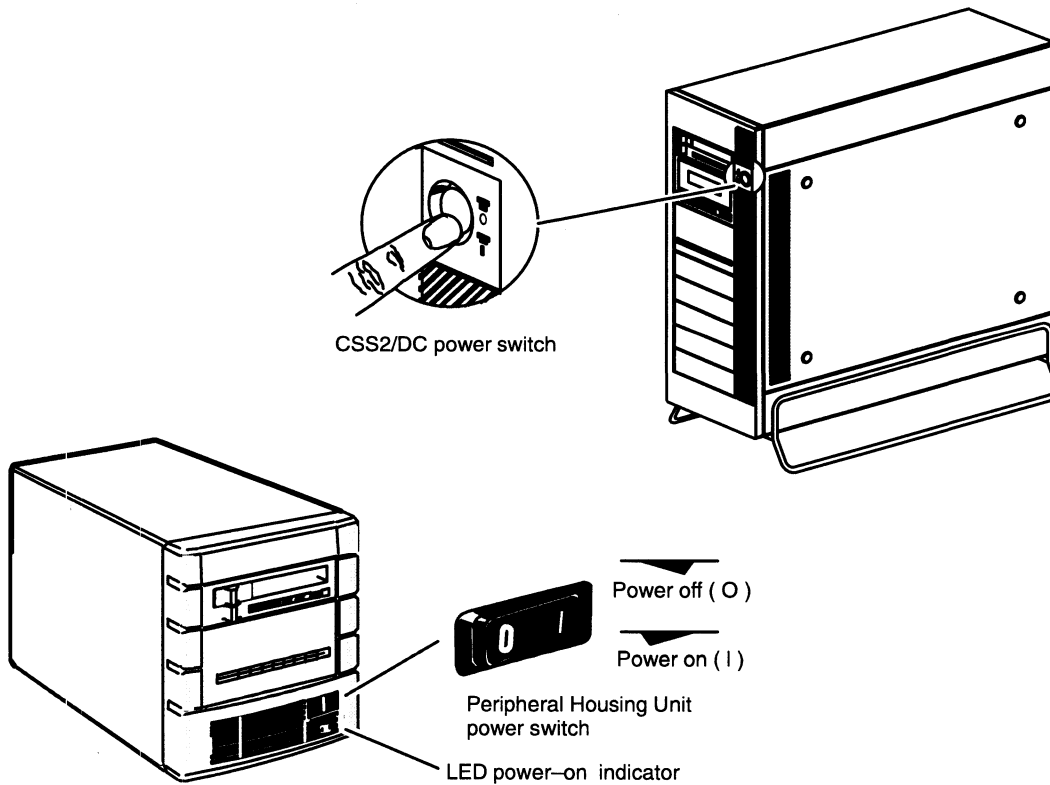

Figure 3-2 Peripheral Subsystem Power Switches

3. If you have a printer or other device connected to your computer system, turn on power and make sure that each is *on line*. For specific information, see the documentation that came with the device.
4. Turn on power to the computer unit by pressing the computer unit's power switch as shown in Figure 3-3.

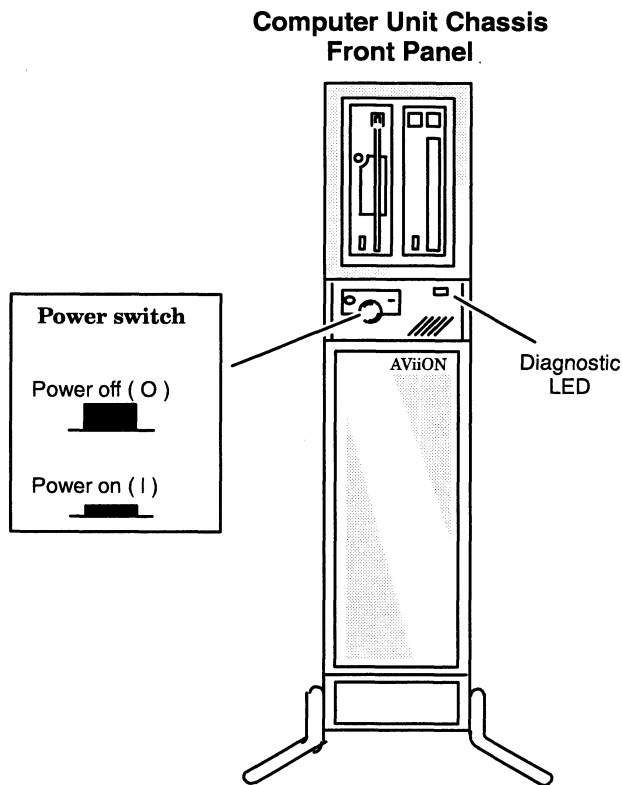
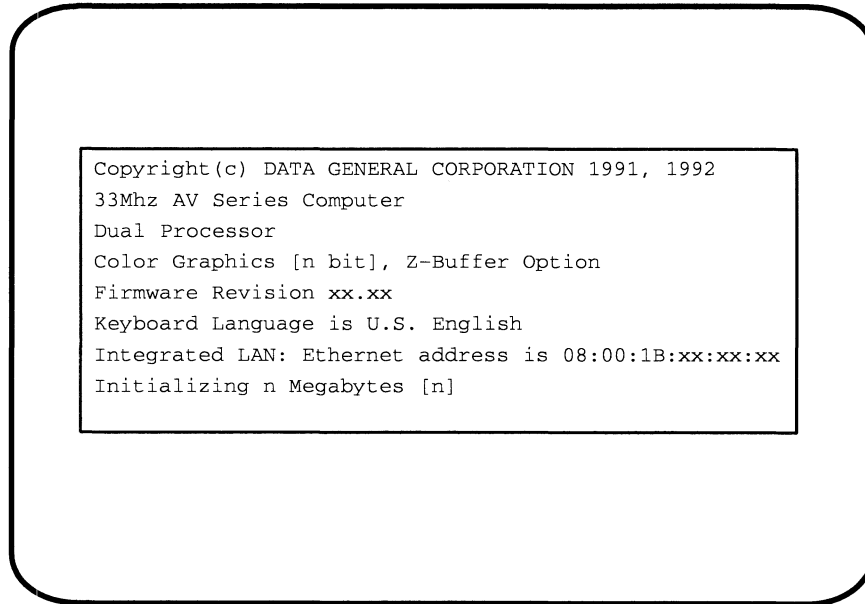

Figure 3-3 Computer Unit Power Switch and LED Power-On Indicator

5. Watch the system console (or graphics display monitor, on an AViiON 530 series system) carefully. You will hear beep tones from the computer unit speaker. After approximately 10 seconds, the screen displays a cursor then initialization messages. Continue with the next step when you see text messages in the powerup window. If the console does not behave in this manner, refer to Appendix C, "Solving Powerup Problems and Exiting the DG/UX Installer."

Your system should display initialization message text similar to the following example:



Where

Dual Processor
Single Processor
n bit
Z-Buffer Option
n Megabytes

Indicates

Second CPU installed
Second CPU option not installed
The type of graphics board installed
Enhanced graphics board installed
The amount of memory installed

NOTE: The display will not specify a keyboard language unless the system includes a graphics controller (AViiON 530 series).

If your display does not appear as described, turn power off to the computer unit, to the graphics or nongraphics console, and to all connected peripherals; wait approximately one minute, and then repeat steps 1 through 4. If the trouble persists, refer to Appendix C, "Solving Powerup Problems and Exiting the DG/UX Installer."

6. Examine the initialization information in your powerup display carefully. Once you have verified that the information is correct, continue with the next step.

NOTE: Write down the computer system Ethernet address for future use.

If any of the initialization messages report inaccurate information, or if your system does not find components that you ordered, contact Data General immediately.

7. After the computer system hardware is initialized, powerup tests begin. As testing progresses, each character in the alphanumeric sequence 0123...ABC...Z appears on the screen, indicating that the hardware has passed a subtest.

Make sure that powerup tests complete. Once the system displays the message `Passed`, continue to the next step. Your console screen appears as follows:

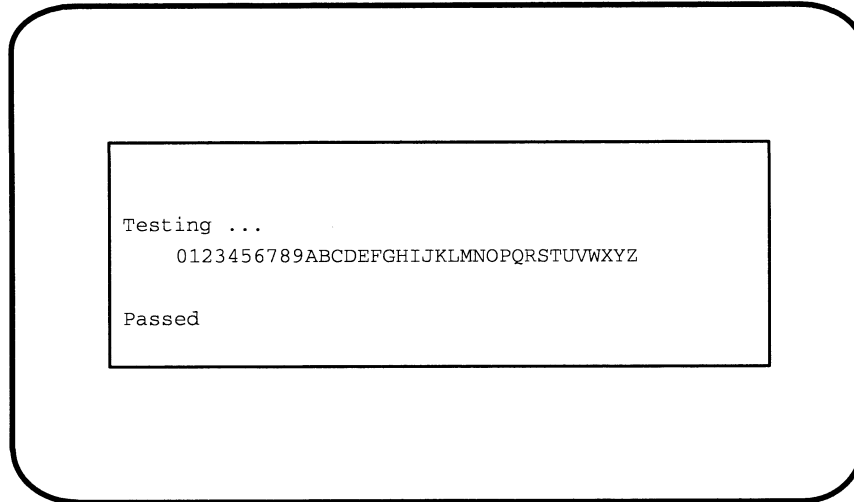

If the test messages are incomplete or include an error message, refer to Appendix C, “Solving Powerup Problems and Exiting the DG/UX Installer.”

8. As long as your computer system retains its original (factory-set) default boot path, it tries to automatically boot the DG/UX installer operating system immediately after powerup testing completes. Your screen display indicates the disk and file that your computer system is attempting to boot, as follows:

```
Booting sd(ncsc(),0)root:/dgux.installer -i
```

What happens next depends on whether you ordered a DG/UX operating system package. The next section describes what your system does in either case.

Your Next Step

If you ordered the DG/UX operating system with your AViiON 530 or 4600 series computer, the system automatically boots the DG/UX installer system. If you did *not* order DG/UX with your computer unit (that is, you intend to run a different operating system, or operate the computer as a client of another operating system server), the automatic boot process will fail. Refer to the following instructions that are appropriate for your specific situation.

Preloaded DG/UX Systems

Once your firmware has successfully booted the installer operating system, the hardware powerup is complete and the booted operating system takes over. The DG/UX Bootstrap program displays initialization and sizing messages, and then enters the DG/UX installer System. Your screen display stops for your input and asks:

```
Do you want to configure any nonstandard devices? [no]
```

You will reach this point each time you power up, until you customize the operating system and reset your automatic boot path as described in *Customizing the DG/UX™ System*.

NOTE: If you ordered a DG/UX operating system package, but the operating system fails to boot automatically, first refer to Appendix C, “Solving Powerup Problems and Exiting the DG/UX Installer,” to verify that the trouble is not due to the way you set up your system hardware. Then try to boot the DG/UX installer operating system manually by typing the following command line at the SCM prompt:

```
SCM> bsd(ncsc(),0)root:/dgux.installer -i
```

If the DG/UX installer operating system fails to boot again, contact Data General as described in the Preface.

In most cases, you should refer now to your DG/UX installation documentation to proceed. We recommend that you follow the step-by-step instructions for installing a standard configuration in *Installing the DG/UX™ System* first, then continue with the more detailed installation information in *Customizing the DG/UX™ System*.

- If you intend to run a 15-minute hardware acceptance test before installing your operating system, refer now to the section “Exiting the Installer System,” in Appendix C.
- If you need to change asynchronous port, display console, mouse, or keyboard configuration parameters before installing your operating system, refer to the section “Exiting the Installer System,” in Appendix C. Once you exit the installer system, refer to Chapter 5, “Using the SCM Configuration Menus.”

Systems Without Preloaded DG/UX

If you did *not* order DG/UX with your computer unit (you intend to run a different operating system, or operate the computer as a client of another operating system server), the automatic boot process will fail.

When the automatic boot sequence fails to boot the DG/UX installer operating system, the System Control Monitor (SCM) displays this message:

```
Unable to load bootfile
sd(ncsc(),0)root:/dgux.installer -i
```

Your system will then display the SCM prompt: SCM>

You have *not* failed the firmware powerup; your system has simply failed to boot the DG/UX installer operating system. Proceed now to your operating system documentation for installation instructions.

For information about the SCM configuration menus, refer to Chapter 5. You can use these menus to change the asynchronous port labeled RS232 -B-, display console, mouse, or keyboard configuration parameters. Once your operating system is installed, you can use an SCM menu to change the default boot path to that of your configured operating system; it will then come up automatically in subsequent powerups.

To run a diagnostics acceptance test, refer to the instructions in the manual *Using AViiON® System Diagnostics*. When you finish running diagnostics, proceed to your operating system documentation for installation instructions.

Shutting Down Your Computer System

Each time you turn off the computer system, you must complete a sequence of shutdown procedures to ensure that data is not lost and that you leave the hardware in the proper state. It is important to bring down your software and turn power off to your computer and peripherals in the correct order.

This section describes the various ways you can shut down your computer system. If your AViiON computer system provides resources for other computers, you probably won't shut it down very often. If you use your computer system as a stand-alone station or as a network client to a server system, however, you are likely to start it at the beginning of each work day and shut it down at the close of the day. Once you become familiar with powerdown, reset, and restart procedures, you won't need to follow the steps in this section to shut down or reset your computer system.

Powering Down

Follow these steps when shutting down the computer system entirely; for instance, at the close of the day, when the computer system won't be used for a long period, or when you plan any kind of hardware maintenance tasks. You may also want to power down if your computer system is experiencing intermittent errors; often the process of restoring hardware components to the powerup state resolves temporary problems, or identifies problems that are not temporary.

CAUTION: *Never turn off power to your computer system before properly shutting down your operating system software. Resetting or cycling power to your computer while the operating system is running may result in lost data.*

1. Shut down your applications and operating system software according to the procedures in your operating system documentation. For a DG/UX system, the sequence to *immediately* shut down the operating system is as follows:

```
# cd / ↵
# shutdown -g0 -y ↵
# halt -q ↵
```
2. Once you see the SCM prompt, you can safely turn off power to the computer unit by pressing the computer unit's power switch.
3. If you have a Peripheral Housing Unit (PHU), Combined Storage Subsystem Deskside Chassis (CSS/DC) or another external storage device connected to your computer system, turn off power to the external unit.
4. If you have a printer or other device connected to your computer system, turn off power. Make sure you turn off power to each device.
5. Turn off power to the monitor or asynchronous terminal.
6. Wait at least a minute before attempting to restart your computer system. Listen for the computer unit fan; do not turn power back on until you hear that the fan has stopped spinning.

Resetting the Computer System

As long as your computer system has completed powerup testing, you can reset the hardware at any time by pressing the Reset/Abort switch on the computer unit rear panel *up*. Figure 3-4 shows the location of the computer unit reset and abort switch.

CAUTION: *Never press the reset switch during powerup testing. If you want to interrupt a powerup sequence, wait until you see the message Passed. Also, remember that resetting or cycling power to your computer while your operating system is running may result in lost data. Always try to shut down your operating system before resetting your computer system.*

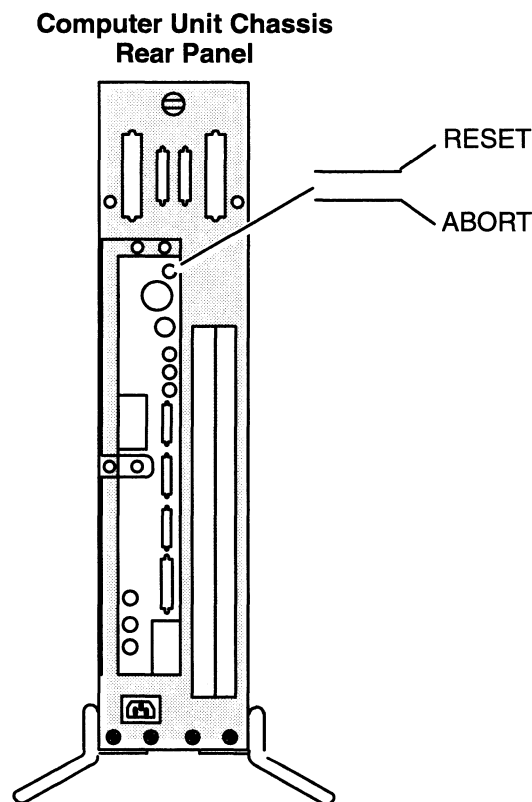

Figure 3-4 Computer Unit Reset and Abort Switch

NOTE: Pressing the Reset/Abort switch *down* (to ABORT) sends an interrupt to the CPU without resetting the system. The effect of this interrupt depends on what operating system or stand-alone software is running at the time of the interrupt; refer to your software documentation to determine the abort switch's use on your system. If, for example, your system includes the DG/UX kernel debugging software, pressing the abort switch brings you to the kernel debugger prompt, described in the manual *Using the DG/UX™ Kernel Debugger*.

You may want to reset the computer system if it seems to be experiencing intermittent errors; often the process of restoring hardware components to the powerup state resolves temporary problems.

Resetting the hardware without cycling power is called a *warm reset*; turning power off and then on again is a *cold reset*. With a cold reset, your system goes through powerup testing and its automatic boot sequence, as described in the “Powering Up” section at the beginning of this chapter. With a warm reset, your computer system restores system board components to their powerup state and displays the System Control Monitor (SCM) command interpreter prompt, but does not proceed through powerup tests or automatically boot your operating system.

You can perform a warm reset without pressing the reset switch by using the SCM **RESET** command while at the SCM prompt, as follows:

```
SCM> r ↵ (or, SCM> reset ↵)
```

Restarting Your System

Each time you turn power on, your system goes through powerup testing and its automatic boot sequence, as described in the “Powering Up” section at the beginning of this chapter. It is not necessary to power down completely in order to restart your operating system, however.

If you shut down your operating system to the SCM prompt or press the reset switch (as described in the previous sections), you can restart your operating system by entering the **BOOT** command at the SCM prompt, as follows:

```
SCM> b ↵ (or, SCM> boot ↵)
```

When you use the **BOOT** command without an argument, the computer system uses its default boot path and boots the same file it uses at every powerup. If you have not set a default boot path, it looks for a bootable file on the first SCSI disk. Refer to Chapter 5 for additional information about the default boot path and the automatic boot sequence; Appendix B contains detailed information about the SCM **BOOT** command and boot syntax.

End of Chapter

Chapter 4

Setting Up and Installing a SCSI Bus

This chapter describes how to plan and configure a Small Computer System Interface (SCSI) bus for AViiON 530 and 4600 series systems. It includes default and recommended SCSI identification numbers, operating parameters for the individual mass-storage drives on the bus, terminating rules, cabling restrictions that apply to your system, and worksheets to help you prepare your SCSI configuration. This chapter also provides instructions for connecting SCSI devices and subsystems to your computer unit.

NOTE: Factory-set SCSI IDs for the internal drives in your system are listed on a label attached to your computer unit's rear panel, above the SCSI connector(s). In most cases, the IDs for factory-installed subsystem devices are listed on a label attached to your PHU or CSS2/DC. Table 4-1 lists the default identification settings and DG/UX device names for AViiON 530 and 4600 series SCSI devices; components purchased together as a system are factory-preconfigured to these defaults.

If your system includes *external* devices (drives or subsystems housed outside the computer unit), you will need the information in the "Connecting an External SCSI Bus to the Computer Unit Rear Panel" section of this chapter to connect those devices to your computer unit. To ensure that your system components work together, you should also fill out the worksheets and make certain that your SCSI bus adheres to the device identification and cable rules described in this chapter. *Before* adding any new internal or external SCSI devices to your system, you should read this chapter to plan your SCSI bus configuration.

NOTE: If your system does *not* include any external SCSI mass-storage subsystems or stand-alone SCSI devices (such as reel-to-reel tape drives), you probably do not need the information in this chapter unless you plan to add more drives. However, you do need to terminate the SCSI bus at the computer unit, as described in Chapter 2.

Planning a SCSI Bus Configuration

You should carefully plan your entire SCSI bus configuration *before* you begin setting up the devices. As you set up your SCSI devices, make sure that your system adheres to the following SCSI device identification, bus cable, and bus termination rules. Use the worksheets in Figure 4-4 along with the information in the following sections to plan and/or verify your configuration.

Your computer unit includes at least one single-ended SCSI bus controller that supports your internal disk, tape, diskette, and CD-ROM drives. This controller is factory-specified as Controller 0 and the bus it supports extends to the external connector labeled SCSI A on your computer's rear panel. An optional second SCSI bus controller (provided on an I/O expansion board) is factory-specified as Controller 1. The second controller supports a bus extending from the connector marked SCSI B on the rear panel. Each SCSI bus in your system can support a total of seven devices housed internally, independently, or within a mass-storage subsystem.

Figure 4-1 shows the location of the SCSI connectors on the rear panel of your computer. (If your system does not include a second SCSI controller, the rear panel slot marked SCSI B will not contain a connector.)

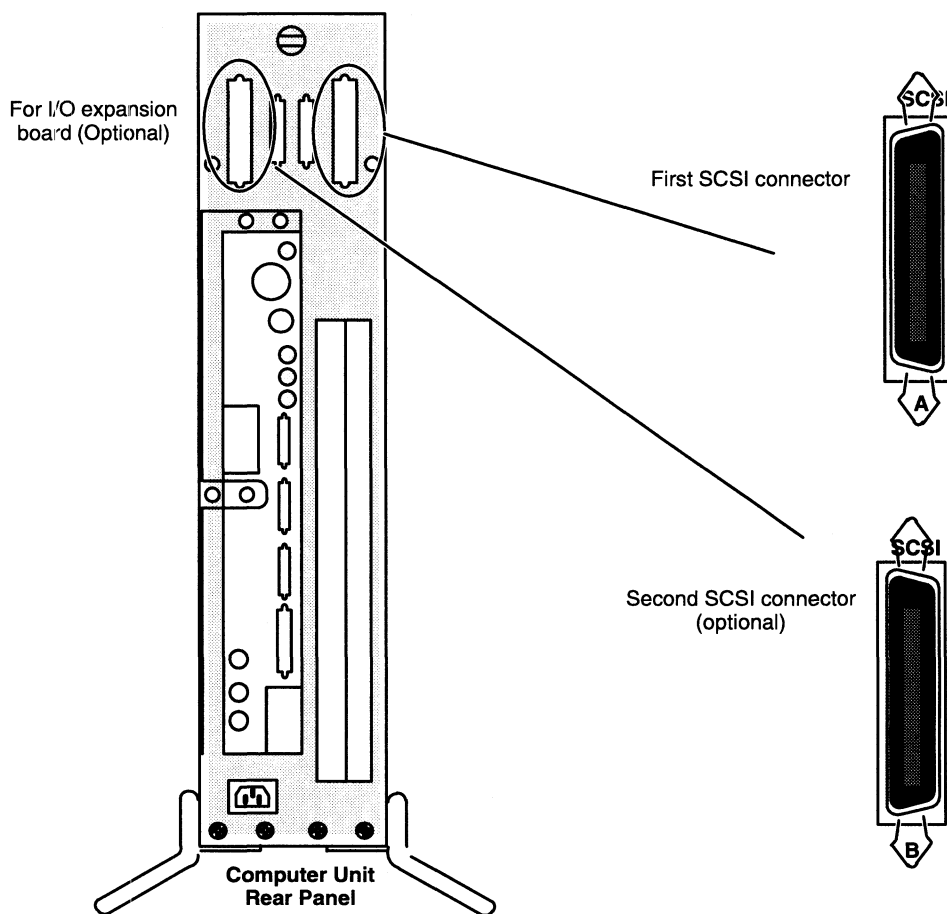

Figure 4-1 AViiON 530 and 4600 Series SCSI Bus Connectors

Identifying SCSI Drives

Each SCSI controller in your computer unit can support a total of seven SCSI devices, *including* internal devices such as tape and disk drives. For example, if your computer includes one tape drive and one SCSI disk on the first bus, you can connect five additional devices to that (Controller 0, SCSI A) bus. If your computer unit includes three internal devices, you can connect only four external devices to the SCSI A bus; the maximum of four internal drives reduces the maximum number of external drives the bus could support to three. Since it does not support internal drives, the second (Controller 1, SCSI B) bus can support seven external SCSI devices. When a single mass-storage subsystem contains multiple drives, each individual drive applies to the seven-device maximum.

Each individual drive on a SCSI bus must have a unique SCSI identification number (also referred to as a *SCSI ID*, *device ID*, or *DID*) with a value from 0 through 6. When you receive preinstalled devices mounted either inside the computer unit or mounted inside a mass-storage housing unit, the SCSI ID numbers are already set. If you add or replace devices anywhere on the SCSI bus, you must set the IDs by positioning drive-select jumpers on the individual device(s).

Table 4-1 lists the default (factory-installed) SCSI device ID numbers for hard disk, diskette, and tape drives. The “DG/UX Device Name” column lists the mnemonic name that the DG/UX operating system and the computer system firmware use to identify a device on the first (controller 0) bus in your system; the mnemonic name includes the SCSI ID of the device.

Table 4-1 Default SCSI Device ID Numbers

Drives	ID Number	DG/UX Device Name
Disk ¹		
First	0	sd(ncsc())
Second	1	sd(ncsc(),1)
Third	2	sd(ncsc(),2)
Fourth	3	sd(ncsc(),3)
Diskette		
First (Diskette LUN 0) ²	1, 2, or 3; determined as next sequential disk (x)	sd(ncsc(),x)0
Second (Diskette LUN 1)		sd(ncsc(),x)1
Cartridge Tape		
First	4	st(ncsc(),4)
Second	5	st(ncsc(),5)
Third	6	st(ncsc(),6)

¹ Includes diskette, optical disk, and CD-ROM drives.

² The SCSI ID of a diskette drive is set on a SCSI adapter board, not on the drive. If you have more than one diskette drive managed by the same SCSI adapter board, the drives have the same SCSI ID number. The LUN (Logical Unit Number) differentiates drives managed by the same SCSI adapter.

A second SCSI bus uses the same recommended device ID assignments as the first. System software recognizes a device on either bus by a combination of the device ID and the controller number (indicated in the () portion of the DG/UX pathname). For example, `sd(ncsc(1)0)` identifies the first hard disk supported by the second SCSI (B) controller. Refer to your DG/UX documentation or Chapter 5 for more information about device specifications.

NOTE: ID assignments do not need to reflect the physical positioning of devices along the SCSI bus; a drive at the physical end of the bus can have a higher or lower device identification number than another drive closer to the SCSI controller in the computer unit.

The DG/UX operating system allows the configuration of any SCSI device at any unique and valid SCSI device ID number. However, other software such as device drivers could limit the use of certain device ID numbers to specific types of devices. Check the drive manual(s), and the documentation for any customized software you plan to run on your system, for further SCSI ID restrictions.

The automatic boot sequence for your computer system looks for a disk at device ID 0 on the first SCSI controller. Therefore, you should assign SCSI device ID 0, Controller 0, to the system (root) disk. Unless you manually change the automatic boot path, this disk will boot automatically when you power up the computer system. You also use the SCSI ID of a device when booting it directly (using the **SCM BOOT** command) or to change the automatic boot path, as described in Chapter 5.

Figure 4-2 shows an example of a valid SCSI ID configuration that follows the pattern of recommended ID assignments.

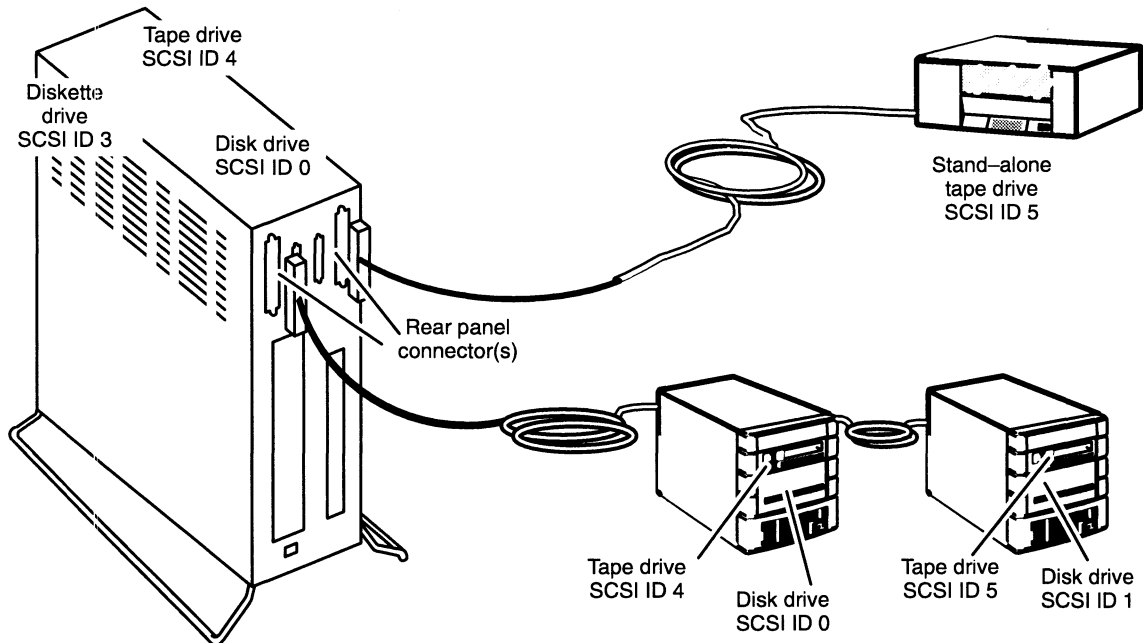

Figure 4-2 Sample SCSI Device Identification Configuration

Labels on the back of your computer unit and subsystem display the device IDs assigned to your mass-storage drives. Before you connect the SCSI bus cable to your computer unit, make certain each device on the bus has a *unique* SCSI ID; if you notice a conflict, you will need to reassign device identifications by changing jumpers on the drive(s).

Examine the configuration labels on the back of your devices or subsystems, and enter the SCSI IDs for each device on the worksheet in Figure 4-4. Verify that each device on a bus has a unique device ID of 0 to 6. If your device ID configuration appears valid, make certain the SCSI bus you plan to install meets the cabling restrictions described in the next section, "SCSI Bus Cabling Rules."

SCSI Bus Cabling Rules

The cabling for a SCSI bus begins inside the computer unit at the SCSI controller and connects the mass-storage devices on the bus in a cabled daisy chain. The maximum length of combined internal and external SCSI bus cabling cannot exceed 19.6 feet per controller. When you calculate the total length of the SCSI bus cabling in your system, consider the following:

- Your system's first connector (SCSI A) supports an external SCSI bus with a cable maximum of 14.85 feet. Of the 19.6-foot cable maximum, 4.75 feet resides within the AViiON 530 or 4600 series computer unit.
- An optional I/O expansion board contains a second SCSI controller and a bus connector (SCSI B) that supports an external SCSI bus with a cable maximum of 18.6 feet. Only 1 foot of the 19.6-foot cable maximum resides within the AViiON 530 or 4600 series computer unit.
- Some peripheral SCSI devices consume internal cable, further reducing the maximum length of your cable configuration. For example:

The Model 10565 PHU uses 2.75 feet of internal SCSI cable.

The CSS2/DC uses 4.83 feet of internal SCSI cable.

The G6587 reel tape drive uses 0.5 feet of internal SCSI cable.

The G6589-A and G6589-TA reel tape drives each use 0.34 feet of internal SCSI cable.

Figure 4-3 illustrates the SCSI bus cable requirements.

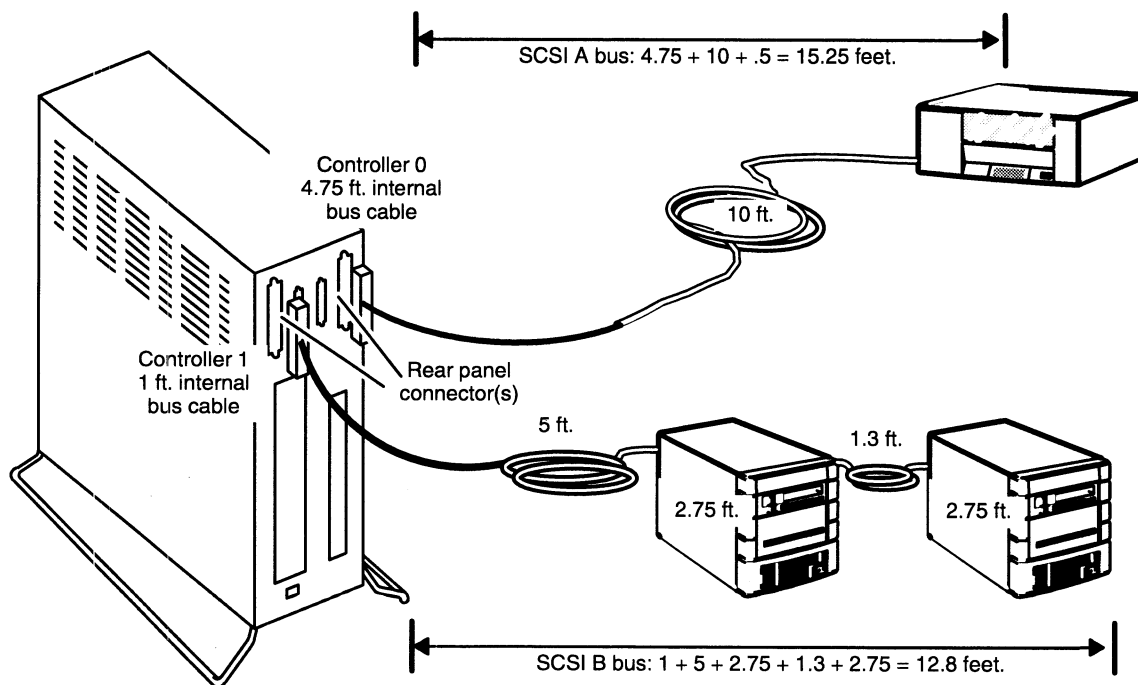

Figure 4-3 Daisy Chain and SCSI Bus Cable Lengths

Configuring Device Operating Parameters

The SCSI devices you received with your system are preconfigured to comply with the operating parameters of the controller and the other drives on the SCSI bus. Before you install an internal or external device on your SCSI bus, you need to set its operating parameters as described in this section. Configure all new or replacement drives as follows:

- Set all disk drives for sequential drive motor start. The drive will then delay starting up its spindle motor a number of seconds (a multiple of the SCSI ID number) when you power up your system.
- Set all drives so that the SCSI bus (host system) provides terminator power rather than the drives themselves. Some devices specify this option as “SCSI pin 26 ON,” or “power from interface cable pin 26.”
- Set any drive that offers these options to *enable* parity checking and arbitration.
- Make sure the bus termination is correct on the new drive:

In an AViiON 530 or 4600 series computer or mass-storage subsystem, *all* drives and SCSI adapter boards must have their SCSI bus terminator resistors *removed*.

Most stand-alone drives employ an external terminator plug to terminate the SCSI bus; if your drive does *not* have an external terminator, and will be physically positioned as the last drive on the SCSI bus, you must install bus termination resistors. Refer to the next section, “Terminating the External SCSI Bus.”

NOTE: For information about setting the SCSI jumpers/switches and removing the terminator resistors, refer to the list of drive installation manuals in the *Guide to AViiON® and DG/UX™ System Documentation*.

Terminating the External SCSI Bus

You must terminate the SCSI bus at the last device or peripheral housing unit on each SCSI bus (SCSI A and SCSI B). Depending on the physical placement and type of SCSI peripherals included in your system, you terminate your bus with one of the following:

- A terminating plug that you install on the unused bulkhead connector on the outside of the unit. On such housings (for example, the Model 10565 Mass Storage Subsystem), *do not terminate any of the SCSI devices within the unit*.
- A terminating resistor pack that you install on an individual drive’s printed-circuit board. Note that devices terminated in this manner must also connect at the physical *end* of any daisy-chain configuration.

To locate the SCSI bus terminators and connectors for each SCSI drive and drive housing in your system, refer to the device-specific manual for that drive or unit.

Internal Drives				
Slot	Drive Type	SCSI ID	Cable Length	
Front	<input type="checkbox"/> half-height left		} 4.75 feet	
	<input type="checkbox"/> half-height right			
	<input type="checkbox"/> full-height			
Back	<input type="checkbox"/> half-height left			
	<input type="checkbox"/> half-height right			
	<input type="checkbox"/> full-height			
<input type="checkbox"/> SCSI Adapter Board				
External Mass-Storage Devices (external connector port A)				
Device	Drive Type	SCSI ID		

Total Cable Length (19.6 feet maximum) _____

External Mass-Storage Devices (external connector port B)			
Device	Drive Type	SCSI ID	Cable Length
			1 foot

Total Cable Length (19.6 feet maximum) _____

Figure 4-4 SCSI Bus Configuration Worksheet

Internal Drives				
Slot		Drive Type	SCSI ID	Cable Length
Front	<input checked="" type="checkbox"/> half-height left	3.5" diskette	(LUN 0)	} 4.75 feet
	<input checked="" type="checkbox"/> half-height right	525-Mbyte QIC tape	4	
	<input type="checkbox"/> full-height			
Back	<input type="checkbox"/> half-height left			
	<input type="checkbox"/> half-height right			
	<input checked="" type="checkbox"/> full-height	662-Mbyte disk	0	
<input type="checkbox"/>	SCSI Adapter Board	for diskette	3	
External Mass-Storage Devices (external connector port A)				
Device		Drive Type	SCSI ID	Cable Length
PHU		1-Gbyte disk	1	} 2.75'
		525-Mbyte QIC tape	5	
				} 5' cable .5'
		Reel tape 6587	6	
Total Cable Length (19.6 feet maximum)				18 feet
External Mass-Storage Devices (external connector port B)				
Device		Drive Type	SCSI ID	Cable Length
CSS2/DC				} 1 foot
		1-Gbyte disk	0	
		1-Gbyte disk	1	} 10' 4.83
		662-Mbyte disk	2	
		2-Gbyte tape	4	
Total Cable Length (19.6 feet maximum)				15.83 feet

Figure 4-5 Sample Configuration Worksheet

Installing a SCSI Bus and SCSI Devices

This section outlines the following steps to physically install a SCSI bus on your system:

- Installing configuration jumpers on each external SCSI tape and/or disk drive
- Connecting the SCSI bus cable in a daisy-chain to the subsystems and stand-alone devices
- Terminating a SCSI bus

To perform each step, you will need the device- and subsystem-specific documentation listed in *Guide to AViON® and DG/UX™ System Documentation* for each bus component.

The next section in this chapter describes how to connect an external SCSI bus to your computer unit.

Before you begin physically installing your SCSI bus and SCSI devices, plan your cabling scheme(s) and assign SCSI ID numbers to each device according to the rules described in the preceding sections of this chapter. Make certain to assign ID numbers compatible with any application software requirements planned for your system.

Figure 4-6 shows a sample AViON 530 and 4600 series SCSI layout that adheres to SCSI bus cable and device identification rules.

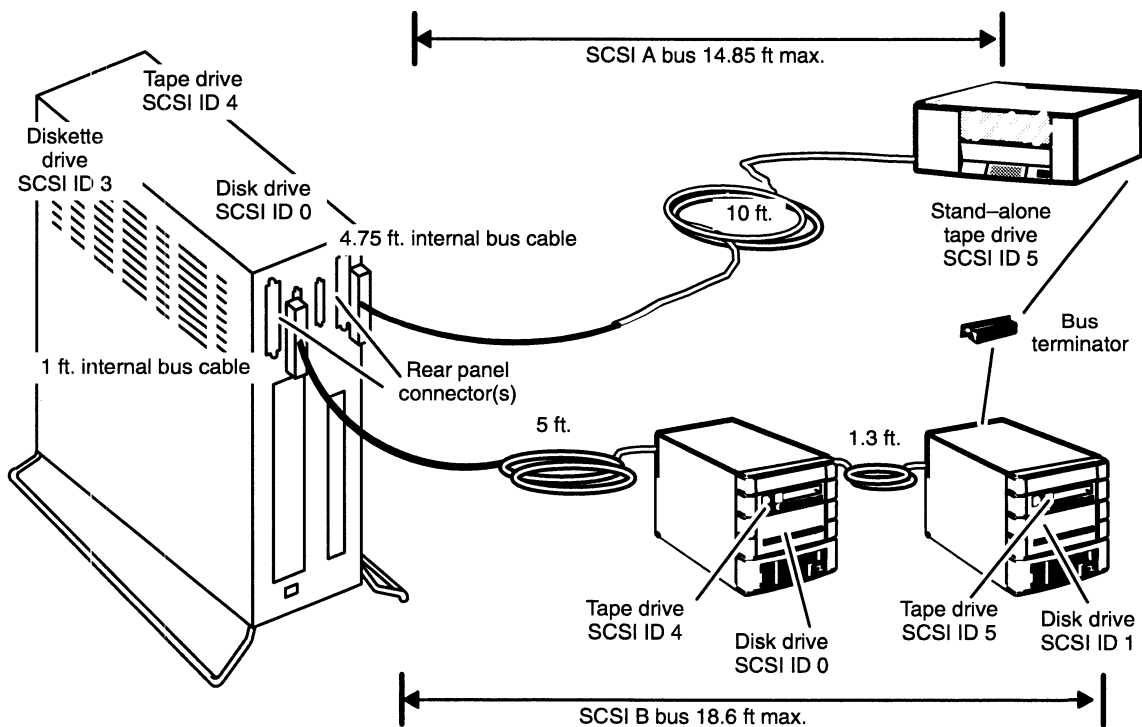

Figure 4-6 SCSI Cable Rules and Sample Device IDs

Installing Configuration Jumpers

The following steps outline how to assign device identifications and operating parameters to your SCSI-based devices. Refer to Chapter 7 in this manual for guidelines on how to handle drives and insert or remove jumpers.

1. Refer to your drive documentation for any stand-alone tape and/or disk drives on your SCSI bus for instructions, and then set the SCSI ID jumpers according to your SCSI bus plan. Make certain the drive's jumper and/or switch settings comply with the operating parameters listed in the previous section, "Configuring Device Operating Parameters."

2. Refer to Chapter 7 in this manual, or the unit manual for any peripheral housing units (such as the Model 10565 Mass Storage Subsystem), for instructions on how to remove any drive whose device ID conflicts with your SCSI bus plan.

NOTE: Each SCSI drive or SCSI adapter board located in a mass storage subsystem must have its own unique ID number.

3. Refer to the device-specific documentation for each drive in the subsystem for instructions, and then set the SCSI ID jumpers according to your SCSI bus plan.
4. Before you replace a drive in your computer unit or subsystem, make certain its jumper and/or switch settings comply with the operating parameters listed in the preceding section, "Configuring Device Operating Parameters."
5. Replace each drive according to Chapter 7, or the peripheral housing unit manual.
6. Modify or attach a label that identifies the SCSI ID numbers assigned to the drive(s) on the outside of the computer unit and each drive or subsystem. Indicate each drive's location in the unit. Document your configuration in the worksheet provided in Figure 4-4.

NOTE: Step 6 is important for those who will operate and maintain your system. Your AViiON system software refers to SCSI drives by identification number and SCSI controller number.

Connecting the SCSI Bus to SCSI Devices

Before you begin connecting your SCSI devices together, locate all of your SCSI bus external cables. Your SCSI bus connects to the computer unit and between devices and subsystems with one of the following 50-pin CHAMP to 50-pin CHAMP cables:

Device	Cable part number	Cable model number	Length (ft.)
SCSI to	005-33003	15325E001	1.3
SCSI	005-33004	15325E005	5
	005-33005	15325E010	10

When you arrange your SCSI drives along the bus, make certain to avoid strain on any part of the SCSI cable.

Refer to your device-specific documentation for instructions, and then install each device along the bus.

Terminating the SCSI Bus

Make certain to properly terminate each SCSI bus on your system at the last drive or subsystem on the bus. If you need to terminate an external SCSI bus, refer to the previous sections “Configuring Device Operating Parameters” and “Terminating an External SCSI Bus.” Chapter 2 describes how to terminate a bus that does not extend outside the computer unit chassis.

Once you have verified your configuration, configured your SCSI drives and devices, connected the devices together, and terminated the last device on the SCSI bus, continue with the directions in the next section, “Connecting an External SCSI Bus to the Computer Unit Rear Panel.”

Connecting an External SCSI Bus to the Computer Unit Rear Panel

Figure 4-7 shows the location of the SCSI connectors on the rear panel of your computer.

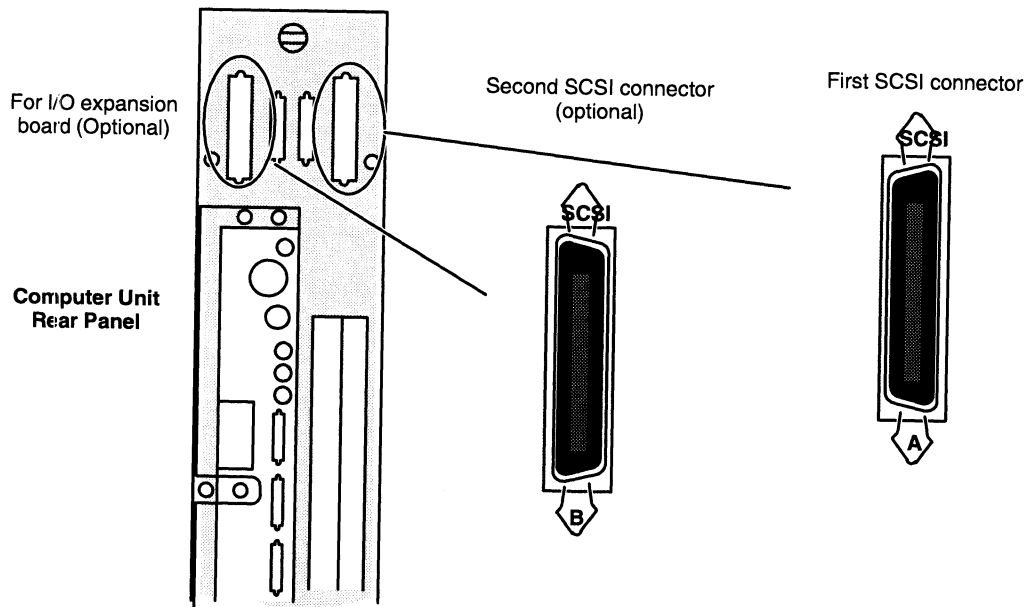

NOTE: If your system does not include an I/O expansion board, the rear panel slot marked "SCSI B" will not contain a connector.

Figure 4-7 AViiON 530 and 4600 Series External SCSI Connectors

After you verify that the cable lengths and SCSI IDs in your configuration adhere to the rules listed earlier in this chapter, follow these steps to connect an external SCSI bus to the rear panel of your computer:

1. Turn off the power to your computer, subsystems, and peripherals before connecting the SCSI bus.
2. If present, remove the SCSI bus terminator plug from the rear panel connector as shown in Figure 4-8. Simply open the spring clips by pushing them vertically, and then pull the plug off.

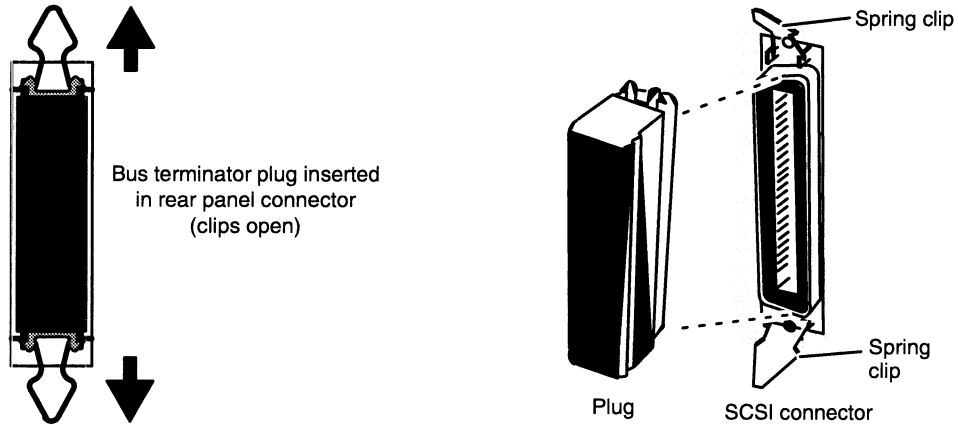

Figure 4-8 Removing the SCSI Bus Terminator Plug

3. Align the cable's D-shaped connector and gently insert the cable in the rear panel connector as shown in Figure 4-9.

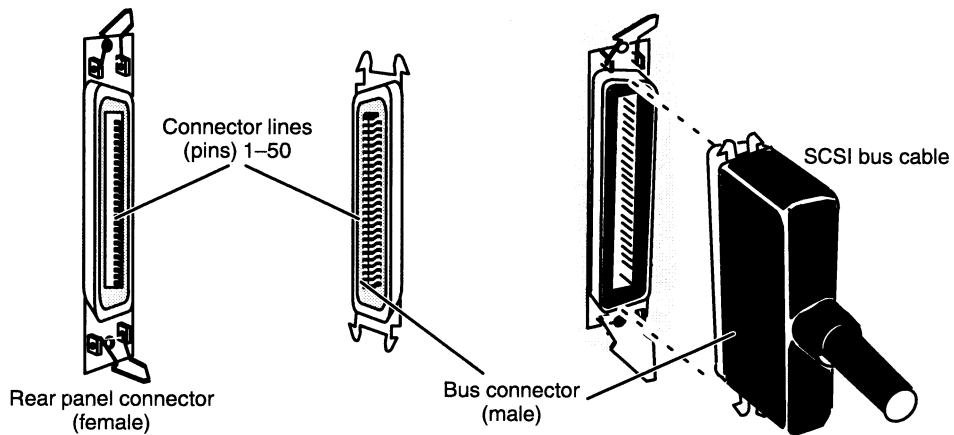

Figure 4-9 Plugging Together SCSI Bus Connectors

4. Push the spring clips attached to the rear panel connector straight down or straight up into the brackets on the cable connector as shown in Figure 4-10.

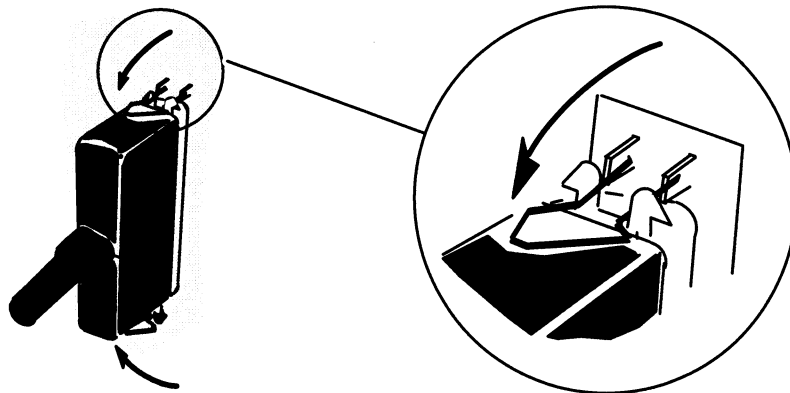

Figure 4-10 Securing a SCSI Cable Connection

If you haven't already connected the remote end of the cable to your first SCSI external device, do so now (refer to the device-specific documentation, if necessary).

If you have just connected your external SCSI bus for the first time, return to Chapter 2, "Setting Up Your Computer System," to complete your installation and connect the ac power cord. Then continue with Chapter 3, "Starting and Stopping Your Computer System," for instructions on powering up a system with external peripherals.

If you just reconnected your cable(s) after adding or replacing a SCSI device, we recommend that you test the device after your next powerup to ensure that the drive is operating correctly in your system configuration. Refer to *Using AViiON® System Diagnostics* to run a diagnostic acceptance test and tests on individual drives.

End of Chapter

Chapter 5

Using the SCM Configuration Menu

This chapter describes the menus you can use to view or change system configuration parameters while in the System Control Monitor (SCM). Use these menus to set configuration parameters before you install your operating system, or to alter an existing configuration.

You must be at the SCM prompt to display the primary SCM menu, View or Change System Configuration. From there, you access all other SCM menus. Refer to the “Powering Up” section of Chapter 3 for information about entering the SCM during your first powerup; Appendix B describes other means of getting to the SCM prompt.

The following section contains a summary of SCM menus and information about using them. The rest of this chapter describes how to use menu items to accomplish common tasks.

Summary of Menus and Menu Conventions

You access all SCM menus from the View or Change System Configuration menu. From this primary menu you can display or modify several system configuration parameters.

To display the View or Change System Configuration menu, use the **FORMAT** command. Enter the following command line at the SCM prompt :

```
SCM> F ↵
```

The system displays the View or Change System Configuration menu, as follows:

```
View or Change System Configuration
1  Change default system boot path
2  Change console parameters
3  Change modem port parameters
4  Change mouse parameters
5  View system configuration
6  Change VME A24 configuration
7  Return to previous screen

Enter choice->
```

Figure 5–1 summarizes the submenus you can access from the View or Change System Configuration menu.

Summary of SCM Menus

*The SCM displays the View or Change System Configuration menu when you enter the **FORMAT** command at the prompt.*

SCM> F ↓

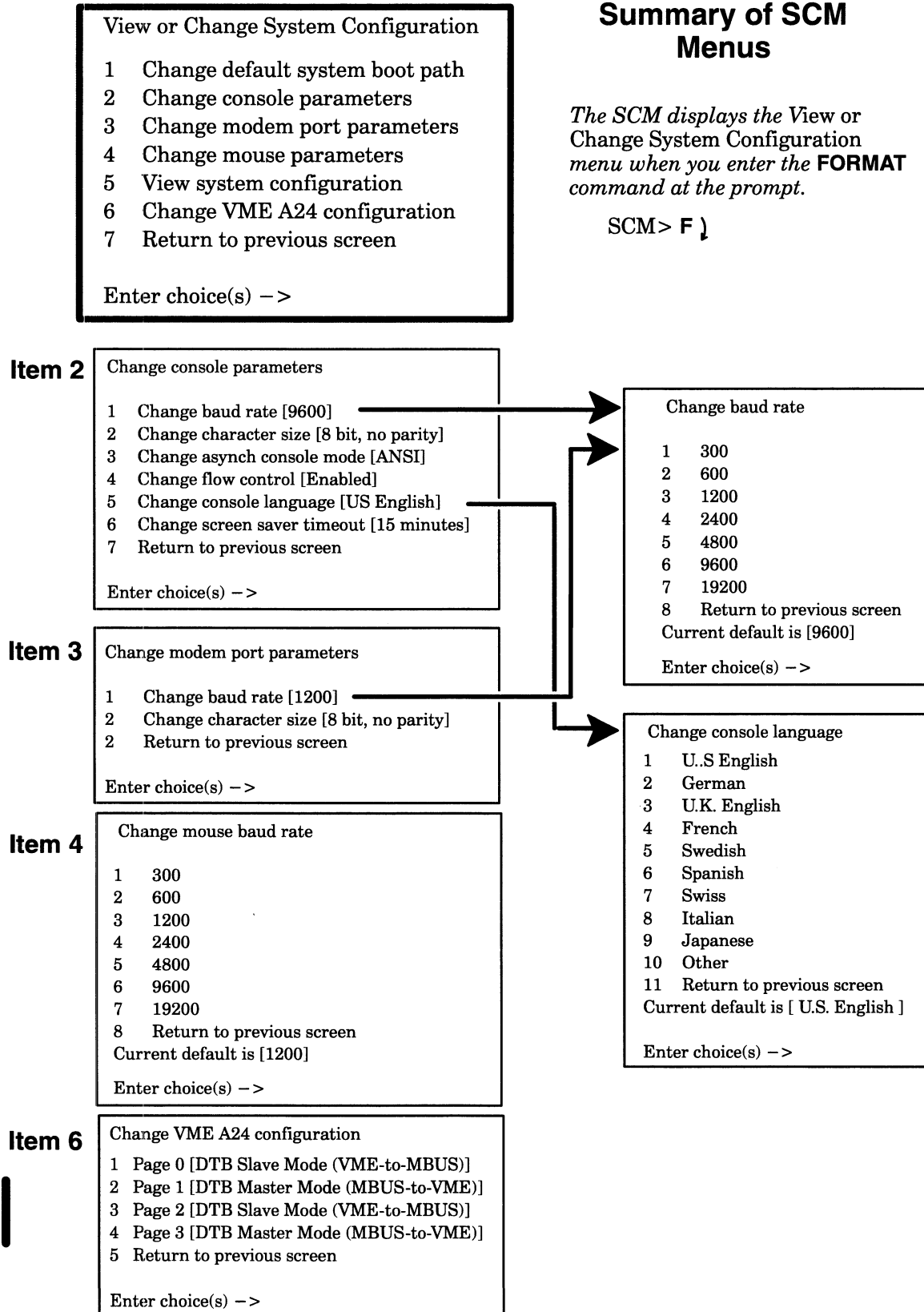

Figure 5-1 SCM Menus

NOTE: With some Data General hardware maintenance and remote assistance agreements, you will see menu items not shown in Figure 5–1. For descriptions of contract–dependent features, refer to the remote assistance and maintenance user’s guide(s) you received with your system.

Changes you make while using SCM menus become effective the next time you power up or reset the computer. You can reset the computer by using the **RESET** command at the SCM prompt or by cycling power to the system. See Chapter 3 for information about operator switches and the powerup process.

You can exit from any menu by selecting the last item on the menu or by pressing New Line at the prompt to select the default. You return to the previous menu, *except* when you leave the View or Change System Configuration menu; when you exit from the View or Change System Configuration menu you return to the SCM prompt.

You can select multiple items to view or change at the Enter choice(s)-> prompt on each menu. The SCM executes the items in sequence before returning to the menu screen. Use a space or a comma to separate item numbers.

The rest of this chapter contains sections that describe how to use menu items accessible from the View or Change System Configuration menu.

Changing the Default System Boot Path

Whenever you start your system, the SCM begins an automatic boot sequence after powerup testing completes. The SCM uses the default system boot path to find the automatic boot device. It uses this same default system boot path whenever you use the **BOOT** command without an argument. The default system boot path is usually your operating system.

If you do not set a valid default system boot path (or if you leave the boot path empty), the default boot path is not initialized. When you power on the computer without an initialized boot path, the SCM uses a hardwired sequence to attempt a boot from the first SCSI disk. If it cannot boot from disk, it enters the System Control Monitor and displays the SCM prompt.

NOTE: If you purchased a preloaded operating system from Data General, the default system boot path was initialized at the factory to boot the DG/UX Starter operating system.

Specifying Boot Devices

This section briefly describes the device specifications for booting your computer from disk or tape or across a LAN. You use this information as a *boot path* argument to the SCM **BOOT** command or as an entry for your system’s *default* boot path in the View or Change System Configuration menu. Refer to Appendix B for details about the **BOOT** command, or for general information about accessing the SCM.

Because the boot process is very flexible, it can sometimes be complex. Therefore, this section provides only a quick reference. Appendix B contains a detailed description of boot path specifications. You may need to refer to Appendix B if you have any nonstandard devices configured with your computer.

About the Bootstrap Process

To identify any peripheral device to the system, you must provide a *device specification*, a software descriptor that uniquely identifies that device. The *boot path* is a device specification for a bootable hardware device and, optionally, a second software descriptor that points to an executable image on the booted media called the *file path*. The SCM passes the file path to the booted program after loading the first stage bootstrap from the boot device.

Together, the boot device specification and the optional file path represent a first and second stage boot process; they comprise a full boot path. Figure 5–2 shows their combined formats. A full boot path contains a maximum of 80 characters.

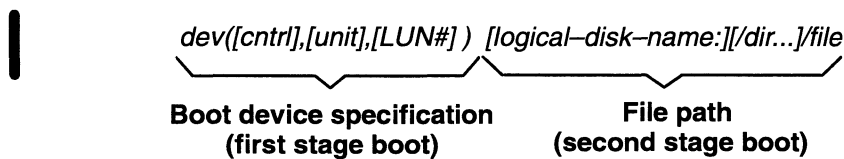

Figure 5–2 Full Boot Path Format

NOTE: The syntax for booting over a LAN is slightly different; refer to the section “Booting Over a Local Area Network.”

The following sections provide first– and second–stage boot path examples for disk, tape, and LAN boot devices.

Booting from Disk or Tape

This section provides first–stage boot path specifications for disk and tape devices installed in a mass–storage subsystem that is connected to the extended SCSI bus. Refer to Chapter 2 for information about connecting a SCSI–based mass–storage device to the rear panel SCSI bus connector. Refer to the “Booting Over a Local Area Network” section for information about booting your computer from a LAN server. Refer to Appendix B for a detailed description of device specification syntax.

Table 5–1 lists the device specification you use when your drives, either internal or external, are installed on the first SCSI bus (controller 0).

Table 5–1 Boot Specifications for Disk and Tape Drives

Device	Specification
First disk drive	sd(ncsc(0),0)
Second disk drive	sd(ncsc(0),1)
Third disk drive	sd(ncsc(0),2)
Fourth disk drive	sd(ncsc(0),3)
First tape drive	st(ncsc(0),4)
Second tape drive	st(ncsc(0),5)
Third tape drive	st(ncsc(0),6)

NOTE: These specifications assume that drive jumpers are set according to their factory configuration.

Your system applies a default value of 0 to an unspecified LUN field. ■

Specifying a Second–Stage Boot File

Typically, the first–stage boot brings up the operating system second–stage bootstrap, which uses any text it finds after the device specification in the boot path to bring up and properly initialize your operating system. You can use this second stage, or *file path*, argument to specify any executable file or program parameter (such as run level). Refer to Appendix B for details.

For example, the file path **usr:/stand/diags** refers to the AViiON System Diagnostics program file, called **diags**, located in the directory **stand** on the logical disk **usr**. To boot **diags** from the disk at SCSI ID 0, use the following full boot path:

sd(ncsc(),0)usr:/stand/diags

You can also specify a tape file number using the file path argument. For example, if **diags** is the third file on a tape defined as SCSI ID 4, the full boot path is **st(ncsc(),4)2**.

Booting Over a Local Area Network

This section provides boot path specifications for LAN devices currently available for use with AViiON 530 and 4600 series systems. Refer to Appendix B for a detailed description of device specification syntax.

Table 5–2 lists the specifications for LAN controllers you may have in your system configuration.

Table 5–2 Specifications for LAN Devices

Device	Specification
First AMD integrated Ethernet LAN	dgen(0)
Second AMD integrated Ethernet LAN	dgen(1)
First VME (Interphase Hawk) Ethernet LAN	hken(0)
Second VME (Interphase Hawk) Ethernet LAN	hken(1)
First VME Token Ring LAN	vitr(0)
Second VME Token Ring LAN	vitr(1)

NOTE: You *cannot* boot over a token ring LAN. The device specifications in Table 5–2 include all LAN devices supported by AViON 530 and 4600 series systems.

When you boot over an Ethernet LAN, the boot device is your computer's LAN controller. In the second-stage bootstrap argument, you optionally specify the Internet address of the server system. For example, the following boot path specifies the server at Internet address **128.111.2.3** on the integrated Ethernet LAN:

dgen(0)128.111.2.3:

Examples of Valid Boot Paths

NOTE: These examples show boot path arguments to the **BOOT** command. Use the boot path text only (not the **b**) if you are using the boot path as a default system boot path entry in the View or Change System Configuration menu.

1. Boot the default system boot path.

```
SCM> b ↵
```

2. Boot from file 0 on the first QIC tape drive in the system.

```
SCM> b st(ncsc(),4) ↵
```

(Default parameters and second stage boot: specifies **st(ncsc(0),4,0)0**)

3. On a multiprocessor computer, boot from the third file on the tape in the second tape drive (SCSI ID 5).

```
Jp#0/SCM> b st(ncsc(),5)2 ↵
```

4. Boot your DG/UX operating system kernel to run level 3.

```
SCM> b sd(ncsc())root:/dgux -3 ↵
```

5. *Using a Danish keyboard*, boot the DG/UX system from the system disk.
SCM> **b sd)ncsc)=,0=rootAE-dgux.file +1 ↵**
6. *Using a Norwegian keyboard*, boot the DG/UX system from the system disk.
SCM> **b sd)ncsc)=,0=rootO-dgux.file +1 ↵**
7. Boot AViiON System Diagnostics (the program file **diags** located in the directory called **stand** on the logical disk **usr**) from the default system disk.
SCM> **b sd(ncsc(),0)usr:/stand/diags ↵**
8. Boot the executable file called **bootfile** in the root directory on the second SCSI disk (SCSI ID 1).
SCM> **b sd(ncsc(),1)root:/bootfile ↵**
9. Boot from the first host that responds on the Ethernet LAN (your computer is connected to only one network).
SCM> **b dgen() ↵**
10. Boot from the host at Internet address 128.111.5.6 on an alternate Ethernet LAN (you are connected to two different LANs, managed by an integrated and a VME Ethernet controller).
SCM> **b hken()128.111.5.6: ↵**

Using the Change Default System Boot Path Menu

To view, initialize, change, and optionally boot the default boot device, follow these steps:

1. While in the View or Change System Configuration menu, type **1** and press New Line to select item 1, "Change default system boot path."
2. The system displays the current system boot path [inside square brackets] with a prompt asking if you want to change the current default boot path, as follows:

```
System boot path = [ ]
Do you want to modify the default boot path? Y/[N]
```

NOTE: The boot path is *not initialized* when the brackets are empty.

To keep the existing boot path, press New Line at the prompt, and then skip to step 5.

```
Do you want to modify the default boot path? [N] ↵
```

To set or change the system boot path, type **y** and press New Line at the prompt.

```
Do you want to modify the default boot path? [N] y ↵
```

The system displays the following prompt.

```
Enter new system boot path ->
```

3. Type a valid boot path (*device specification*) and press New Line. Refer to the last section of this chapter, “Specifying Boot Devices” for valid entries.

For example, to boot the DG/UX operating system from the first SCSI disk — boot path **sd(ncsc(),0)** and file path **root:/dgux** — type the following:

```
Enter new default boot path -> sd(ncsc(),0)root:/dgux ↵
```

The SCM will now automatically boot DG/UX from this disk at every powerup.

4. After you specify a new default boot path, the SCM displays your entry in brackets, followed by a prompt giving you a chance to make further changes, as follows:

```
System boot path = [sd(ncsc(),0)root:/dgux]
Do you want to modify the default boot path? [N]
```

Press New Line to accept the new boot path. Enter **y** and repeat step 3 to change the boot path again.

5. The system prompts you to boot from the new default boot path.

```
Do you want to boot? [N]
```

To return to the View or Change System Configuration menu without rebooting, press New Line. The next time you do reboot, the SCM will use the new default system boot path.

6. To boot, type **Y** and press New Line .

```
Do you want to boot? [N] y ↵
```

The next message you see is from the program you booted.

Changing Console Parameters

Items on the Change Console Parameters menu allow you to set the operating parameters for a device connected to the system console port (or to view the default values for these parameters). The following subsections describe how to view or change console parameters.

The *system console* refers to the keyboard and display device that receive powerup diagnostic test messages and from which you bring up your operating system. In most cases, the system console communicates directly with the computer’s system board.

The system console port is the *first* RS–232 port on the computer unit rear panel (labeled A); refer to Chapter 2 for information about its rear panel location and about connecting an asynchronous terminal.

A computer’s system console consists of either an asynchronous terminal or a graphics monitor and keyboard. You can use items 4, 5, and 6 on the Change Console Parameters menu if you have a graphics monitor rather than an asynchronous terminal as system console. Items 1, 2, and 3 are only useful if you connect an asynchronous terminal for use as a system console.

NOTE: If you connect a terminal for use as a system console, make sure that the characteristics settings on the terminal correspond to the parameter settings for the system console port.

Power down the computer before connecting a new terminal or changing the terminal characteristics via external switch settings.

If you have a workstation, you *must* disconnect the graphics monitor and keyboard before powering up using a terminal as system console.

You can use a keyboard control sequence (Ctrl-I) to restore the parameters for the system console port to the following factory defaults: 9600 baud, 8 data bits, no parity, ANSI character set, enabled flow control, U.S. English keyboard language. Refer to Appendix B for a description of keyboard control sequences.

Changing the System Console Baud Rate

While in the View or Change System Configuration menu, type **2** and press New Line to select item 2, “Change console parameters.” The system displays the Change Console Parameters menu, with the current baud rate shown in brackets next to item 1, “Change baud rate.” Use item 1 to change the baud rate for the system console port. The default baud rate is 9600 baud.

NOTE: Item 1 applies only if you are using an asynchronous terminal as system console; this parameter does not apply to a graphics monitor.

```

Change console parameters
1  Change baud rate [9600]
2  Change character length [8 bit, no parity]
3  Change asynch console mode [ANSI]
4  Change flow control [Enabled]
5  Change console language [US English]
6  Change screen saver timeout [15 minutes]
7  Return to previous screen

Enter choice(s) ->

```

Type **1** and press New Line to select item 1, “Change baud rate.” The system displays the Change Baud Rate menu.

```
Change baud rate

1      300
2      600
3      1200
4      2400
5      4800
6      9600
7      19200
8      Return to previous screen
Current baud rate [9600]

Enter choice(s)->
```

Type the item number of the baud rate you want and press New Line. You return to the Change Console Parameters menu. The baud rate you select will be the default for your system console port the next time you power up or reset the system.

Changing the System Console Character Length

While in the View or Change System Configuration menu, type **2** and press New Line to select item 2 “Change console parameters.” The system displays the Change Console Parameters menu, with the current value in brackets next to item 2, “Change character length”. Use item 2 to change the default character size for your system console port. The default value is 8 data bits, no parity.

NOTE: Item 2 applies only if you are using an asynchronous terminal as system console; this parameter does not apply to a graphics monitor.

```
Change console parameters

1      Change baud rate [9600]
2      Change character length [8 bits, no parity]
3      Change asynch console mode [ANSI]
4      Change flow control [Enabled]
5      Change console language [US English]
6      Change screen saver timeout [15 minutes]
7      Return to previous screen

Enter choice(s) ->
```

Type **2** and press New Line to select item 2, “Change character length.” The system displays the Change Character Size menu.

```

Change character size

1      8 bit, no parity
2      7 bit, even parity
3      7 bit, odd parity
4      7 bit, mark parity
5      7 bit, no parity
6      Return to previous screen

Current character size is [8 bit, no parity]

Enter choice(s)->

```

Type the item number of the character size you want and press New Line. You return to the Change Console Parameters menu. The character size you selected will be the default for your system console port the next time you power up or reset the system.

Changing the System Console Mode

While in the View or Change System Configuration menu, type **2** and press New Line to select item 2 “Change console parameters.” The system displays the current value in brackets next to item 3 on the Change Console Parameters menu. Use item 3, “Change async console mode” to change the default character code setting for the system console port. The default character mode is ANSI. The alternate is DG mode. Refer to the documentation that came with the terminal for information about supported character modes.

NOTE: Item 3 applies only if you are using an asynchronous terminal as system console; this parameter does not apply to a graphics monitor.

```

Change console parameters

1      Change baud rate [9600]
2      Change character size [8 bit, no parity]
3      Change async console mode [ANSI]
4      Change flow control [Enabled]
5      Change console language [US English]
6      Change screen saver timeout [15 minutes]
7      Return to previous screen

Enter choice(s) ->

```

CAUTION: *The console character code set must be ANSI if you use the DG/UX operating system.*

Type **3** and press New Line to select item 3, “Change asynch console mode.” If the character set is currently ANSI, you will change the specification to DG mode. If the character set is currently DG mode, you will change it to ANSI. You return to the Change Console Parameters menu without further screen display. Select item 3 again to toggle it to its previous setting. The character mode selected when you exit from the Change Console Parameters menu will be the default for your system console port the next time you power up or reset the system.

Enabling or Disabling Flow Control

With flow control (XON/XOFF protocol) enabled, you can use the Ctrl–S sequence to suspend screen output and Ctrl–Q to resume screen display while in the SCM. Flow control is enabled within the SCM by default.

While in the View or Change System Configuration menu, type **2** and press New Line to select item 2 “Change console parameters.” From there, you can use item 4, “Change flow control” to enable or disable the default flow control setting (while in the SCM).

The system displays the current value in brackets on the Change Console Parameters menu.

```
Change console parameters

1      Change baud rate [9600]
2      Change character size [8 bit, no parity]
3      Change asynch console mode [ANSI]
4      Change flow control [Enabled]
5      Change console language [US English]
6      Change screen saver timeout [15 minutes]
7      Return to previous screen

Enter choice(s) ->
```

If flow control is currently enabled, selecting item 4 will disable it; if flow control is currently disabled, the selection will enable it.

NOTE: Your selection at this menu does not affect flow control for your operating system or stand–alone programs.

Changing the Keyboard Language

To select an international font to match your keyboard, use item 5, “Change console language” on the Change Console Parameters menu. U.S. English is the default language in the SCM. The system displays the current value in brackets on the Change Console Parameters menu, and in your powerup initialization display. To change the current keyboard language, complete the following steps.

1. While in the View or Change System Configuration menu, type **2** and press New Line to select item 2 "Change console parameters." The system displays the Change Console Parameters menu, as follows:

```
Change console parameters

1      Change baud rate [9600]
2      Change character size [8 bit, no parity]
3      Change asynch console mode [ANSI]
4      Change flow control [Enabled]
5      Change console language [U.S. English]
6      Change screen saver timeout [15 minutes]
7      Return to previous screen

Enter choice(s) ->
```

2. Type **5** and press New Line to select item 5, "Change console language." The system displays the Change Console Language menu, as follows:

```
Change console language

1      U.S. English
2      German
3      U.K. English
4      French
5      Swedish
6      Spanish
7      Swiss
8      Italian
9      Japanese
10     Other
11     Return to previous screen

Current language is [U.S. English]

Enter choice(s)->
```

3. Proceed to the next step if your keyboard language does not appear on the Change Console Language menu.

If the language that is compatible with your keyboard and system software *does* appear on the menu, select the corresponding item number and press New Line. You will return to the Change Console Parameters menu. The next time you reset or restart your computer, the system will use the new console language.

4. If your keyboard language is *not* listed in items 1 through 9 but *is* listed in Table 5–3, you initialize your language type by selecting item 10, “Other.” The system prompts you for the numeric code for your keyboard type. The item number of the current type appears in brackets next to the prompt, as follows:

```
Enter language type [1]:
```

NOTE: Type 1 is the U.S. English keyboard.

Enter the code for your keyboard type and press New Line, as follows.

```
Enter language type [1]: 11 ↵
```

You return to the Change Console Language menu, where your new selection appears in brackets, for example [type 11]. You will need to reset or restart your computer before booting the operating system to use the new console language.

Table 5–3 Alternate Keyboard Codes

Alternate Keyboard Language	Keyboard Type Code
Danish	10
Norwegian	11
Portuguese	12

NOTE: When you initialize a keyboard language using item 10, “Other,” the console language remains U.S. English *within the SCM*; however, the SCM passes the alternate language type to your operating system or other system software. You will need to use special keyboard characters in order to use your keyboard while you are in the SCM. Refer to step 5. and step 6. in the “Examples of Valid Boot Paths” section for alternate boot command syntax.

Changing the Screen–Saver Timeout

To increase or decrease the amount of time your computer monitor remains inactive before implementing the screen saver function, select item 6, “Change screen saver timeout” on the Change Console Parameters menu. The default is 15 minutes. The system displays the current value in brackets on the Change Console Parameters menu.

While in the View or Change System Configuration menu, type **2** and press New Line to select item 2 “Change console parameters.” From there, type **6** and press New Line to select item 6, “Change screen saver timeout.”

```

Change console parameters

1      Change baud rate [9600]
2      Change character size [8 bit, no parity]
3      Change asynch console mode [ANSI]
4      Change flow control [Enabled]
5      Change console language [US English]
6      Change screen saver timeout [15 minutes]
7      Return to previous screen

Enter choice(s) ->

```

The system displays the current screen saver timeout value along with a prompt asking whether or not you want to change the timeout, as follows:

```

Screen saver timeout = 15 minutes
Do you want to change this (y/[n])?

```

To keep the timeout, press New Line. You return to the Change Console Parameters menu.

To change the timeout, type **y** and press New Line at the prompt.

```

Screen saver timeout = 15 minutes
Do you want to change this (y/[n])? y ↵

```

The system displays a new prompt, where you enter the number of minutes you want the monitor screen to remain on before it goes blank.

```

Enter new timeout value -> 5 ↵

```

You return to the Change Console Parameters menu, with the new default displayed.

Changing Modem Port Parameters

Use the Change Modem Port Parameters menu to specify the proper configuration for the modem port.

The modem port is the second RS-232 port on the computer unit rear panel, labeled B; Chapter 2 describes its rear panel location. When you change modem port parameters, you change the characteristics of this second serial port. If you do not have a modem, you can use the modem port for any asynchronous device. Make sure that characteristic settings on the device you have connected to that port correspond to the parameters set with this menu.

NOTE: The SCM will not specify parameters for the third asynchronous port (labeled RS232-C) on AViiON 530 or 4600 systems. Set parameters for the “C” port through your operating system as an open user dev/tty terminal node.

While in the View or Change System Configuration menu, type **3** and press New Line to select item 3, "Change modem port parameters." The system displays the Change Modem Port Parameters menu (with current default values in brackets), as follows:

```
Change modem port parameters

1      Change baud rate [1200]
2      Change character size [8 bit, no parity]
3      Return to previous screen

Enter choice(s)->
```

Select the item you want to change (baud rate or character length) by entering the item number and pressing New Line. The system prompts you with a menu. Proceed with the instructions in the appropriate section below.

Changing the Modem Port Baud Rate

The default baud rate for the modem port is 1200 baud. The system displays the current baud rate in brackets. Refer to the documentation that came with your modem for information about the correct baud rate.

To change the baud rate of your modem port, follow these steps:

While in the Change Modem Port Parameters menu, type **1** and press New Line to select Item 1, "Change baud rate." The system displays the Change Baud Rate menu.

```
Change baud rate

1      300
2      600
3      1200
4      2400
5      4800
6      9600
7      19200
8      Return to previous screen
Current baud rate [9600]

Enter choice(s)->
```

Type the item number of the baud rate you want, and press New Line. The baud rate you select will be the default baud rate for your modem port the next time you reset or restart the computer.

Changing the Modem Port Character Size

Use item 2, “Change character size” to toggle the default character size setting for your modem port. The default value is 8 data bits, no parity. Refer to the documentation that came with your modem for information about setting the correct character length and parity.

While in the Change Modem Port Parameters menu, type **2**, and press New Line to select item 2, “Change character size.” The system displays the following menu:

```
Change character size

1      8 bit, no parity
2      7 bit, even parity
3      7 bit, odd parity
4      7 bit, mark parity
5      7 bit, no parity
6      Return to previous screen

Current character size is [8 bit, no parity]

Enter choice(s)->
```

The next time you reset or restart your computer, the system will conform to the character size last set.

Changing the Mouse Baud Rate

Use the Change Mouse Baud Rate menu to specify the proper configuration for your computer’s mouse, or to view the current default values (Current baud rate).

While in the View or Change System Configuration menu, type **4** and press New Line to select item 4, “Change mouse baud rate.” The system displays the following menu:

```
Change mouse baud rate

1      300
2      600
3      1200
4      2400
5      4800
6      9600
7      19200
8      Return to previous screen
Current baud rate [1200]

Enter choice(s)->
```

Type the item number of the baud rate you want and press New Line. Refer to the documentation that came with your mouse for information about supported baud rates. The next time you reset or restart your computer, the system will use the baud rate you set.

Viewing the System Configuration

While in the View or Change System Configuration menu, type **5**, and press New Line to select item 5, "View system configuration." The system displays the same information you see in the powerup initialization messages.

The display indicates what revision of PROM software is installed in your system, how many processors are installed, the type (if any) of graphics controller, and the keyboard language for a graphics console. It shows memory module numbers for each available slot and lists whether the slot contains a memory module or not. The following example shows the memory configuration display for a computer with one pair of 16-Mbyte memory modules. Refer to Chapter 8 for configuration limitations and instructions for removing and installing memory modules.

```
Firmware Revision xx.xx
Single Processor
Color Graphics [none/8-bit/24-bit]
Current Keyboard language is [U.S. English

Memory size is 32 Mbytes
Top of memory = 1FFFFFFC hex
Top of memory for use = 1FDFFFC hex
Memory module 0 contains 16 Mbytes
Memory module 1 contains 16 Mbytes

Integrated SCSI:
  ID 0: MAXTOR Disk Drive, Boot specification - sd(ncsc(0),0)
  ID 1: MAXTOR Disk Drive, Boot specification - sd(ncsc(0),1)
  ID 4: ARCHIVE Tape Drive, Boot specification - st(ncsc(0),4)
  ID 5: ARCHIVE Tape Drive, Boot specification - st(ncsc(0),5)

Integrated LAN: Ethernet Address is 08:00:1B:xx:xx:xx
                : Boot specification - dgen(0)

Press any key to continue....
```

Changing the VME A24 Configuration

It is very unlikely that you will ever need to complete the steps in this section. The Change VME A24 Configuration menu allows you to alter the way default system address mapping allows access to VME A24 space. *You do not need to reconfigure A24 space if you purchased VME controllers from Data General.*

CAUTION: *Do not make changes in the VME A24 configuration menu unless you have one or more A24-type controllers **and** you are familiar with VME programming and configuration concepts.*

Logic within the system board controls access to portions of system address space. Address decoders, in conjunction with programmable address maps, regulate accesses to and from the system board. The Mbus Address Decoder (MAD) enables Mbus access, and the VMEbus Address Decoder (VAD) enables access from a VME controller to a location or resource in system memory. MAD and VAD mapping determine, in part, how the system accesses the 16 megabytes of A24 address space. At powerup, PROM code loads and verifies the MAD and VAD to default values. The “Change VME A24 configuration” menu allows you to change this default A24 space mapping.

An A24 board that directs data transfers between itself and other VMEbus boards contains a *MASTER module*. If the same board contains memory accessible from the VMEbus, it also contains a *SLAVE module*. When a VME A24 Location Module is in SLAVE mode, it detects Data Transfer Bus (DTB) cycles initiated by a MASTER and can transfer data between itself and the MASTER. When A24 is in MASTER mode, it initiates DTB cycles in order to transfer data between itself and a SLAVE module. Since A24 space is partitioned into four 4-megabyte pages, you can specify which pages of A24 Address space function in SLAVE mode and which are in MASTER mode using this menu.

The combination, type, and use of VME A24 controllers in your system determine how you should configure A24 address space.

Refer to your *Programming System Control and I/O Registers* manual for more information about memory maps and address decoding.

To change the default VME A24 configuration, type **6** and press New Line while in the View or Change System Configuration menu to select item 6, “Change VME A24 configuration.” The system displays the following menu:

```
Change VME A24 configuration
```

```
1 VME A24 Page 0 [(DTB Slave Mode (VME-to-MBUS))]  
2 VME A24 Page 1 [(DTB Master Mode (MBUS-to-VME))]  
3 VME A24 Page 2 [(DTB Slave Mode (VME-to-MBUS))]  
4 VME A24 Page 3 [(DTB Master Mode (MBUS-to-VME))]  
5 Return to previous screen
```

```
Enter choice(s)->
```

The system displays the current value in brackets next to the item for each page of VME A24 space. The screen above shows the default configuration. If an A24 page is currently configured in **SLAVE** mode, you will change the default to **MASTER** mode by selecting the corresponding item number; if the page is currently in **MASTER** mode, you will change it to **SLAVE**.

Type the item numbers of pages you want to toggle, and press New Line. The next time you reset or restart your computer, the system will conform to the new configuration parameters.

End of Chapter

Chapter 6

Expanding and Maintaining Your Computer System

This chapter contains procedures you should perform each time you replace a failed system component or add new components to your system. It also describes some procedures you might need to perform, such as installing configuration jumpers or calculating power requirements, in the course of installing a new or replacement device.

The first major section in this chapter, “Maintaining Your System,” outlines what you should do if a problem occurs with your system hardware. The second major section, “Reviewing System Specifications,” contains important instructions and worksheets to help you plan the addition of any new system components. You need to follow the directions in the third major section of this chapter, “Avoiding Electrostatic Discharge (ESD) Damage,” each time you open your computer unit or unpack a new component. Since installing a new or replacement device often requires that you set configuration jumpers and switches on the device, the section “Installing Board Jumpers and Setting Switches” provides basic instructions for this procedure. The last sections of this chapter explain how to open and close the computer unit.

NOTE: For information on the periodic maintenance of individual system components such as tape, disk, and diskette drives, refer to the device-specific manual for operating each drive listed in *Guide to AViiON® and DG/UX™ System Documentation*.

Maintaining Your System

In general, you maintain your AViiON 530 or 4600 series system by simply replacing any component that has failed. We refer to the subassemblies that you can easily remove and install as *customer replaceable units*, or simply *CRUs*.

The graphics and nongraphics consoles, cables, and other devices listed in Chapter 2, “Setting Up Your Computer System,” are *external* CRUs. You replace an external CRU by simply disconnecting and reconnecting one or more cables. Refer to Chapter 2 for the procedures for adding or replacing external CRUs.

Internal CRUs reside within your computer unit and include mass-storage devices, the power supply, the fan assembly, memory modules, a CPU complex board, a Z-buffer board, graphics boards, the system board, and an I/O expansion board. To add or replace an internal CRU, you must remove the cover of the computer unit.

Chapter 4 “Setting Up and Installing a SCSI Bus” describes how to add or replace drives and subsystems connected to the SCSI A and SCSI B connectors on the rear of your computer unit.

If a Computer System Problem Occurs

If you have a problem with your computer system, first read Appendix C, “Solving Powerup Problems and Exiting the DG/UX Installer.” It lists problems that could occur during powerup and provides suggestions that you can use to solve these problems.

If your computer passes powerup testing but still indicates a hardware problem, you might want to run a diagnostic test on the system or a particular component. Refer to *Using AViiON® System Diagnostics* for a description of the diagnostics available for your system, and instructions on how to run them.

If you cannot resolve the problem yourself, contact Data General as described in the Preface. If, after calling the Data General Service Center, you determine that a CRU needs replacement, refer to Chapter 2 if the CRU is external. Follow the procedures for removing and installing an internal CRU in subsequent chapters of this manual *after* you have reviewed the appropriate sections of this chapter. Refer to Chapter 4 if the CRU is an external SCSI device.

CAUTION: *Before attempting to replace or add a CRU, read the section in this chapter on “Avoiding Electrostatic Discharge (ESD) Damage” so that you do not damage the replacement or add-on CRU.*

NOTE: If you have determined that the problem is in the peripheral housing unit (PHU), refer also to the manual *Installing and Operating the Model 10565 Peripheral Housing Unit*. If you have determined that the problem is in the combined storage subsystem deskside chassis (CSS2/DC), you will need the manual *Installing and Maintaining the CSS2/DC*.

Reviewing System Specifications

This section contains information you should know before removing or installing any hardware equipment in your computer system. It specifically covers the following procedures you should perform before unpacking or installing a new internal option:

- Review your system specifications to ensure hardware and software support for any planned additions to your computer system.
- Calculate your system’s power requirements to ensure that the configuration you plan doesn’t exceed the limits of your power supply.

Verifying Support for Your Configuration

This section outlines factors you should consider as you plan and review the type, number, and arrangement of the various hardware and software elements that make up your computer system. We refer to these combined factors as your system *configuration*.

- Review the options listed in Chapter 1 and Appendix A to determine whether your system supports the configuration you want.

- Review your system software documentation, Release Notice(s), Updates, and application documentation. These books can provide valuable information you should know *before* you install any new system components. A review of your system documentation might, for example, reveal an incompatibility between your current configuration and a proposed hardware addition.
- Carefully consider site requirements, whether or not your system needs additional drivers for the planned expansion, cable and cable-length restrictions, and any other hardware or software configuration restraints.
- If you intend to add or replace a mass-storage device on a system SCSI bus, make certain your new drive complies with the parameters described in Chapter 4 “Setting Up and Installing a SCSI Bus.”

If your proposed expansion appears acceptable, continue with the next section to ensure that the power supply for your computer system can support the entire new configuration.

Calculating Power Requirements

The combination of boards, drives, and other devices powered by your computer unit cannot consume more electrical power than the computer’s power supply can provide. Before you begin installing options, you should calculate the electric current and power requirements of the proposed configuration, and then compare those totals with your power supply’s maximum output. If the new configuration exceeds system power limits you will need to eliminate some part of the proposed system.

This section explains how to calculate and compare the necessary power information; it also contains a calculation form and completed sample form. The procedures may appear complicated; they actually require only that you perform some simple addition, and then compare the results.

To calculate the current totals and total wattage of the planned configuration, follow the steps below. Use the Current and Power Calculation Form in Figure 6-2 and the example of Figure 6-1 as you proceed; you might want to copy these forms for future use.

1. Refer to Table A–1 in Appendix A of this manual for the current requirements of every device in your planned configuration that will draw power from your computer power supply. Enter each value on your calculation form.

NOTE: Be certain to include all devices that draw current power from the computer unit’s power supply, but not those that draw power from another source. For example, your calculations must include keyboards for graphics monitors and mouse devices, but monitors, most keyboards, and mass-storage subsystems do not draw current from the system power supply. Do *not* list the fan assembly, which has exclusive use of the +9-volt dc power supply output.

If your configuration includes devices not listed in this manual or *Setting Up and Installing VMEbus Options in AViiON® Systems*, refer to the device-specific technical manuals to determine *current draw* (the amount of electric current the device draws from your power supply).

Enter each memory module at the “average” current draw listed in Table A–1. This incorporates “active,” “peak,” and “passive” current draws into a single calculated value.

2. Calculate the total amount of current needed by your system devices by adding the values in each column. Enter the totals on your calculation form in the “Calculated Totals” column of the Power Supply/Amperage section.
3. Compare the current limits with your current totals from step 2.

If any current draw total exceeds the limit for that power source, your proposed configuration will not work; recalculate your current requirements and/or plan another system configuration.

If the current draws are within the maximum provided by each power source, continue verifying your power requirements by calculating the wattage total for the planned system.

4. Multiply the number of volts from each dc power source (5, 12, and 12) by the corresponding amperage totals you calculated in step 2. Enter the results on your calculation form in the “Calculated Totals” column of the Power Supply/Wattage section.
5. Add the wattage values for each voltage source and enter the total in the lower right corner of your form as “Total wattage.”
6. Compare the maximum wattage supplied by your power supply with the total wattage of all sources from step 5.

If the total wattage consumed by the devices in your proposed configuration exceeds the capabilities of your computer unit’s power supply, the configuration will not work; recalculate your current requirements and/or plan another system configuration.

Figure 6-1 shows a completed calculation form for a possible AViiON 530 or 4600 series computer.

Device	Current (Amperes)		
	+5 V dc	+12 V dc	-12 V dc
0 AViiON 530/4600 SYSTEM BOARD	17	1.0	.5
1 CPU complex	2.5	0	0
2 2nd CPU complex	2.5	0	0
3 4 Mbyte Memory; 2 @ +5 .1 = .2	.2	NA	NA
4 16 Mbyte memory; 2@ .15 = .3	.3	NA	NA
5 662 Mbyte hard disk	2.0	4.0	NA
6 525 Mbyte QIC tape drive	1.5	1.5	NA
7 3.5" diskette	0.51	1.0	NA
8 VME options:			
9 slot 1 - VSC/3 sync controller	3.4	.07	.07
10 slot 2 - VAC/16 async controller	4.5	.25	.25
11 SCSI adapter board (for Diskette)	.07		
12			
13			
14			

SAMPLE
SAMPLE
SAMPLE

Power Supply

	Limits	must exceed	Calculated Totals		
Amperage:	↓	↓	↓	↓	↓
+ 5 V Total (amperes max. 37) > ?		<u>34.48</u>	<u>7.82</u>	<u>.82</u>	
+12 V Total (amperes max. 10) > ?					
-12 V Total (amperes max. 1.0) > ?					
Wattage (volts x amperes drawn):		↓	↓	↓	↓
+5 V wattage total 5 x		<u>34.48A</u>	<u>7.82A</u>	<u>.82 A</u>	= <u>172.40 W</u>
+12 V wattage total 12 x					= <u>93.84 W</u>
-12 V wattage total 12 x					= <u>9.84 W</u>
Power supply output <u>326</u> watts > ?			Total wattage=		<u>276.08 W</u>

Device	Current (Amperes)		
	+5 V dc	+12 V dc	-12 V dc
0 <u>AViiON 530/4600 SYSTEM BOARD</u>	<u>17</u>	<u>1.0</u>	<u>.5</u>
1 <u>CPU complex (AV 4625)</u>	<u>3.5</u>	<u>0</u>	<u>0</u>
2 <u>2nd CPU complex (AV4625)</u>	<u>3.5</u>	<u>0</u>	<u>0</u>
3 <u>4 Mbyte Memory; 2 @ +5 .1 = .2</u>	<u>.2</u>	<u>NA</u>	<u>NA</u>
4 <u>16 Mbyte memory; 2@ .15 = .3</u>	<u>.3</u>	<u>NA</u>	<u>NA</u>
5 <u>662 Mbyte hard disk</u>	<u>2.0</u>	<u>4.0</u>	<u>NA</u>
6 <u>525 Mbyte QIC tape drive</u>	<u>1.5</u>	<u>1.5</u>	<u>NA</u>
7 <u>3.5" diskette</u>	<u>0.51</u>	<u>1.0</u>	<u>NA</u>
8 <u>VME options:</u>			
9 <u>slot 1 - VSC/3 sync controller</u>	<u>3.4</u>	<u>.07</u>	<u>.07</u>
10 <u>slot 2 - VAC/16 async controller</u>	<u>4.5</u>	<u>.25</u>	<u>.25</u>
11 <u>SCSI adapter board (for Drive)</u>	<u>.07</u>		
12 _____			
13 _____			
14 _____			

**SAMPLE
SAMPLE
SAMPLE**

Power Supply

	Limits	must exceed	Calculated Totals		
Amperage:	↓	↓	↓	↓	↓
+ 5 V Total (amperes max. <u>.37</u>) > ?		<u>36.48</u>	<u>7.82</u>	<u>.82</u>	
+12 V Total (amperes max. <u>1.0</u>) > ?					
-12 V Total (amperes max. <u>1.0</u>) > ?					
Wattage (volts x amperes drawn):		↓	↓	↓	↓
+5 V wattage total 5 x		<u>36.48A</u>	<u>7.82A</u>	<u>.82 A</u>	= <u>182.40 W</u>
+12 V wattage total 12 x					= <u>93.84 W</u>
-12 V wattage total 12 x					= <u>9.84 W</u>
Power supply output <u>326</u> watts > ?			Total wattage=		<u>286.08 W</u>

Figure 6-1 Sample Current and Power Calculation Form

Device	Current (Amperes)		
	+5 V dc	+12 V dc	-12 V dc
0 AViON 530/4600 SYSTEM BOARD	17.0	1.0	0.5
1 CPU complex board		0	0
2			
3			
4			
5			
6			
7			
8			
9			
10			
11			
12			
13			
14			

Power Supply

Limits must exceed Calculated Totals

Amperage:

+ 5 V Total (amperes max. 37) > ?

+12 V Total (amperes max. 10) > ?

-12 V Total (amperes max. 1.0) > ?

Wattage (volts x amperes drawn):

+5 V wattage total 5 x = _____ W

+12 V wattage total 12 x = _____ W

-12 V wattage total 12 x = _____ W

Power supply output 326 watts > ? Total wattage = _____ W

Figure 6-2 Current and Power Calculation Form

If your proposed new configuration meets all the power requirements described in this section, you can install the new system component(s). Continue with the next section *before* opening your computer unit.

Avoiding Electrostatic Discharge (ESD) Damage

When your computer unit top and side panels are installed, they protect the electronic circuits inside the computer unit from electrostatic discharge (ESD) damage. However, when you remove the panels from the computer unit to install a subassembly, you can inadvertently damage the electronic circuits in the computer unit by simply touching them and discharging any electrostatic charge that has accumulated on your body. This section contains procedures that you must follow to prevent ESD damage to the computer unit.

- Provide enough room to work on the equipment. Clear the work site of any unnecessary materials or materials that naturally build up electrostatic charge. These include plastic foam packaging materials and cups, cellophane wrappers, and similar materials.
- Do not remove a subassembly from its antistatic packaging until the exact moment that you are ready to install it.
- Gather all the tools, manuals, an ESD kit (an ESD wrist strap shipped with your computer system), and other materials you will need before you remove covers and panels from the equipment. The chapters on adding or replacing a subassembly list required tools and materials at the beginning of the procedures. After you remove a cover or panel, you should avoid moving away from the work site; otherwise, you may build up an electrostatic charge.
- Use an ESD kit when handling a subassembly or when touching the electronic circuits inside the equipment. (The section on “Opening the Computer Unit” in this chapter tells you how to attach this wrist strap.) If you lose your ESD strap, you can order an ESD kit from Data General. If an emergency arises and an ESD kit is not available, follow the procedures in the section “Emergency Procedures (without an ESD kit).”
- Replace the cover(s) or panels(s) on the equipment as soon as possible so that the electronic circuits are protected.

Emergency Procedures (without an ESD kit)

In an *emergency* when an ESD kit is not available, use the following procedures to reduce the possibility of an electrostatic discharge by ensuring that your body and the subassembly are at the same electrostatic potential.

CAUTION: *These procedures are not a substitute for the use of an ESD kit. Follow them in the event of an emergency.*

- Before touching any electronic circuits or boards inside the equipment, firmly touch a bare (unpainted) surface of the equipment.

- Before removing any replacement or upgrade subassembly from its antistatic bag, place one hand firmly on an unpainted surface of the chassis, and at the same time, pick up the replacement or upgrade subassembly while it is still sealed in the antistatic bag. Once you have done this, *do not* move around the room or contact other furnishings, personnel, or surfaces until you have installed and *secured* the subassembly in the equipment.
- Remove the subassembly from the antistatic bag, handling printed-circuit boards by the edges. Avoid touching components and circuits on a printed-circuit board.
- If you must move around the room or touch other surfaces before securing the subassembly in the equipment, first place the subassembly back in the antistatic bag. When you are ready again to install the subassembly repeat these procedures.
- Order an ESD kit for the next time you need to add or remove a cover or panel. You can order an ESD kit from Data General.

Installing Board Jumpers and Setting Switches

When you install new or replacement devices in your system, you often need to specify configuration parameters by setting jumpers and/or switches on the individual devices. This section explains how to physically change the jumper and switch settings on boards and drives. These guidelines apply to SCSI device configuration as described in Chapters 4 and 7, and at various points throughout the succeeding chapters of this manual.

Before you begin configuring a device, you will need the following:

- A thorough understanding of the section “Avoiding Electrostatic Discharge (ESD) Damage” in this chapter
- The device-specific technical manual for your option that shows the location of the jumpers and switches
- Nonmagnetic needlenose pliers
- Nonmagnetic jeweler’s screwdriver or another small-pointed device (such as a ball point pen or paper clip end) to push DIP switches.

Installing Jumpers

Jumpers, or jumper plugs, are small removable plastic posts that contain wire circuit connectors. *Jumper pins* are rows of small metal posts sticking out from the board surface. Figure 6-3 shows a row of jumpered and unjumpered jumper pins.

CAUTION: *You can ruin the entire device by bending or breaking these delicate pins; exercise extreme care when installing or removing jumper plugs.*

To install or remove jumpers from a device, follow these steps after setting up an ESD kit:

1. Remove the device from its antistatic bag and place it, component-side up, on a static-free surface. Do not touch the electronic components on the boards; handle printed-circuit boards by the edges only.
2. Refer to your device-specific technical manual to determine the location of the jumper(s) you need to change.
3. Use needlenose pliers to carefully pull the proper jumper(s) *straight up* and off the pin. Do not pull the plug from side to side, twist it, or otherwise risk bending or breaking the pins.

Use needlenose pliers to carefully align and start pushing jumpers *straight* onto the proper pins; then push the jumper completely onto the pins with your finger, if necessary. You should not need to force a jumper into place if you install the proper jumper in the right location.

Figure 6-3 shows how to install and remove jumpers from a typical row of pins.

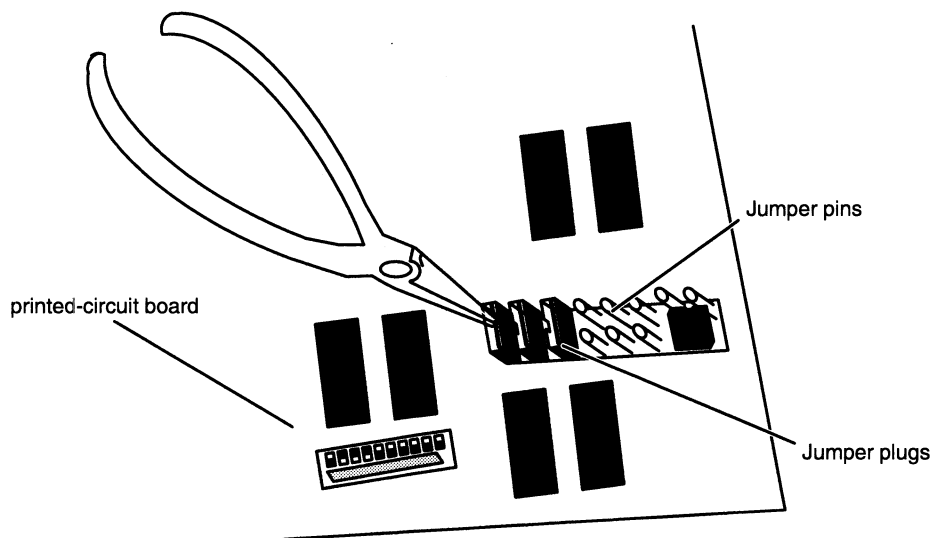

Figure 6-3 Removing or Installing Jumper Plugs

Setting Switches

Some boards use DIP switches to determine certain settings. To alter switch settings on a printed-circuit board, follow these steps *after* setting up an ESD kit:

1. Remove the device from its antistatic bag and place it, component-side up, on a static-free surface. Do not touch the electrical components on the board; handle printed-circuit boards by the edges only.
2. Refer to your device-specific technical manual to determine the location and in/out position of the switches you need to change.

- Use a nonmagnetic pointed device to carefully push the proper switch(es) to the in or out position, as required. Figure 6-4 shows a typical row of DIP switches.

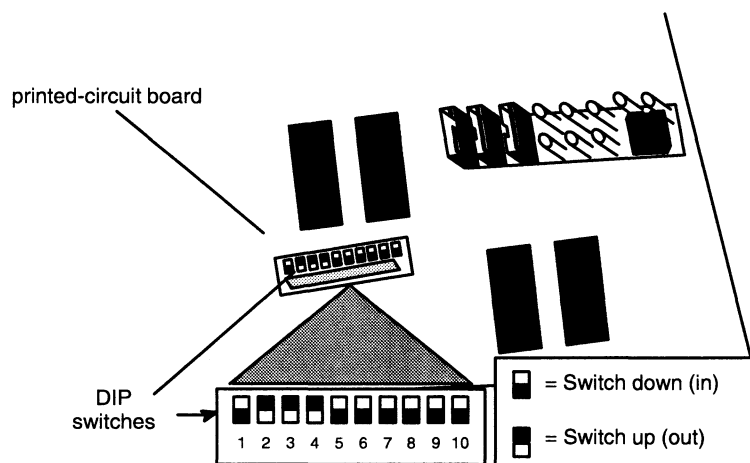

Figure 6-4 DIP Switches on Printed-Circuit Boards

Opening the Computer Unit

To remove or install a device inside the computer, you must remove the top and or side cover(s) from the housing. Make sure you have read and understand the “Avoiding Electrostatic Discharge (ESD) Damage” section of this chapter before you open the computer unit. You will need a coin or large flat-blade screwdriver to open the computer unit.

The following steps tell you how to remove the side and top covers from the computer unit’s housing.

Removing the Side Covers

- Power down the computer system. Refer to the “Shutting Down Your Computer System” section of Chapter 3 for the proper procedure to power down the computer system.

WARNING: To avoid electrical shock or equipment damage, always power down the computer unit and unplug the power cord from the ac power outlet and from the receptacle on the back of the computer unit before removing the covers from the computer unit.

- Reposition the computer system, if necessary, so you can gain access to the left or right side. As you reposition the computer system, be careful not to strain the cables or jar the computer system.
- Using a coin or screwdriver, loosen each fastener by turning it one-quarter turn counterclockwise as shown in Figure 6-5.

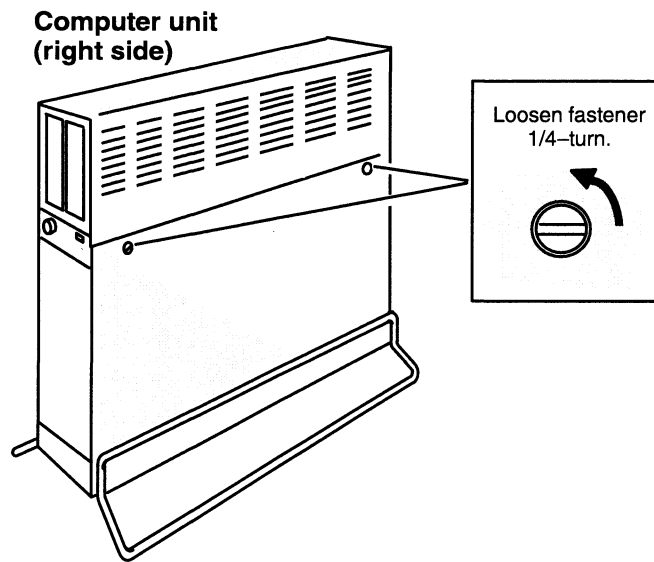

Figure 6-5 Loosening the Side Cover Fasteners

4. While supporting the side cover, lift it up and away from the computer unit as shown in Figure 6-6.

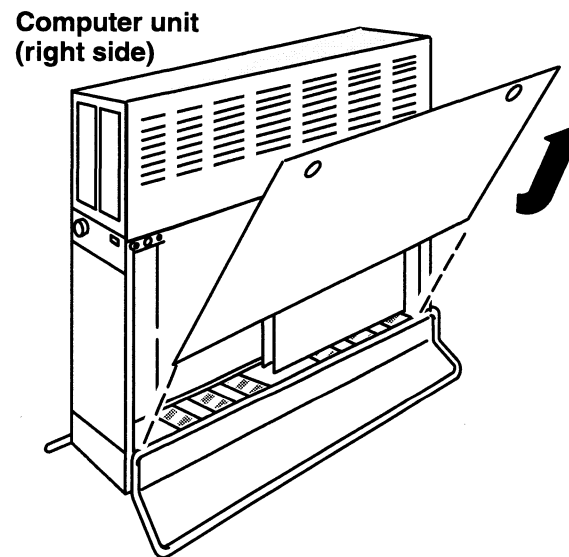

Figure 6-6 Removing the Side Covers

5. Put on the ESD wrist strap and attach the ESD clip to any unpainted metal surface of the chassis as shown in Figure 6-7.

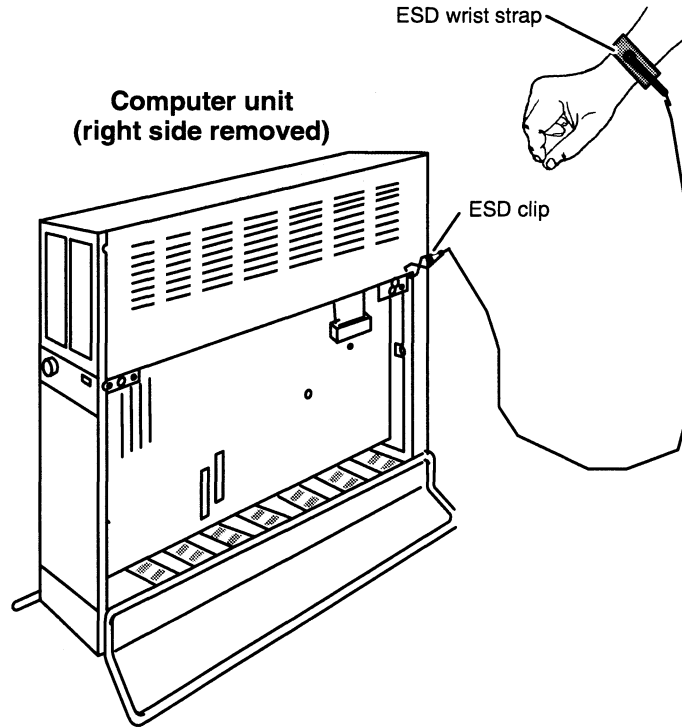

Figure 6-7 Attaching the ESD Wrist Strap and Clip

Removing the Top Cover

1. Power down the computer system. Refer to the “Shutting Down Your Computer System” section of Chapter 3 for the proper procedure to power down the computer system.

WARNING: To avoid electrical shock or equipment damage, always power down the computer unit and unplug the power cord from the ac power outlet and from the receptacle on the back of the computer unit *before* removing the covers from the computer unit.

2. Using a coin or screwdriver, loosen the fastener by turning it one-quarter turn counterclockwise as shown in Figure 6-8.

3. Push the top cover toward the back of the computer unit and remove the cover as shown in Figure 6-8.

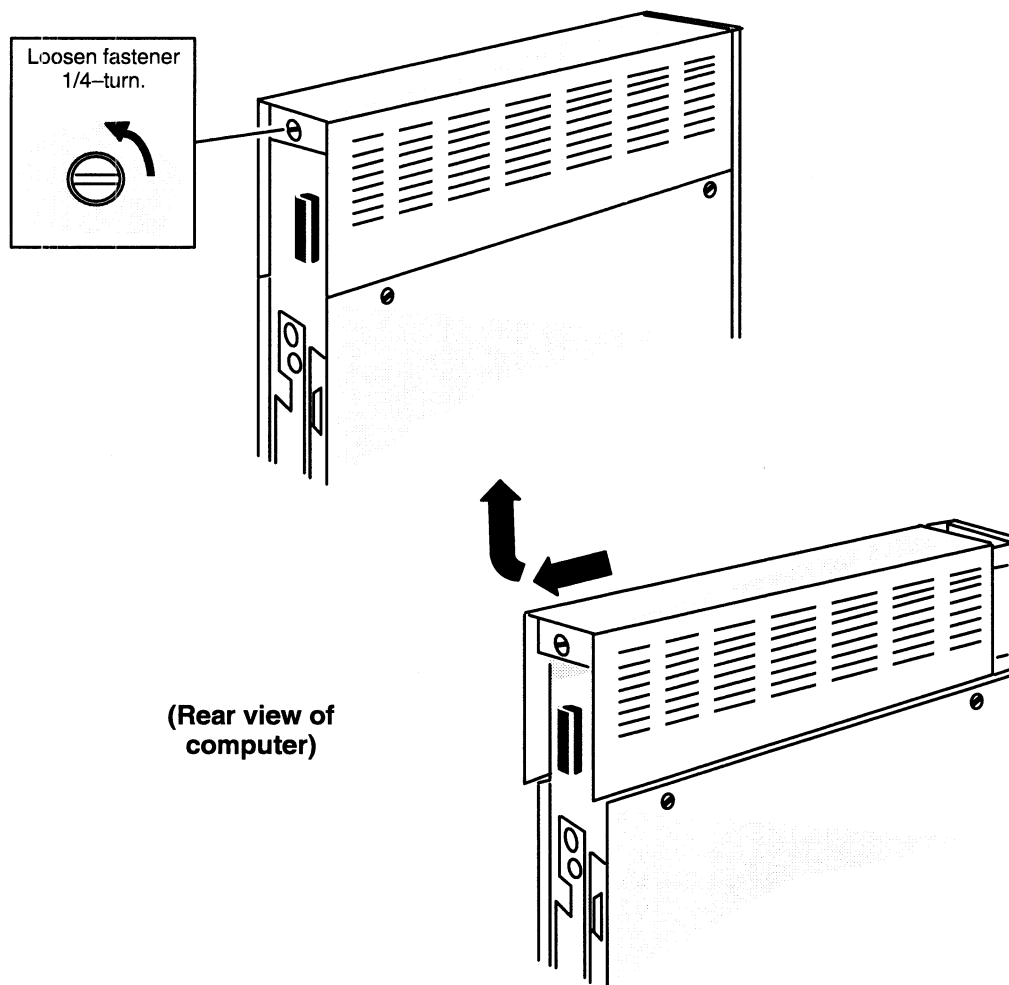

Figure 6-8 Removing the Top Cover

Closing the Computer Unit

This section tells how to reinstall the computer unit's top and side covers. You must install the top cover before you install the side covers.

Installing the Top Cover

To reinstall the top cover, follow the steps below. You will need a coin or a large flat-blade screwdriver.

1. Remove the ESD clip from the computer unit and take off the ESD wrist strap. Store the wrist strap in a safe place for future use.
2. Place the top cover on top of the computer unit.

3. Push the top cover toward the front of the computer unit, as shown in Figure 6-9 until the front edge of the top cover is flush with the front edge of computer unit.
4. Using a coin or screwdriver, tighten the fastener by turning it one-quarter turn clockwise as shown in Figure 6-9.

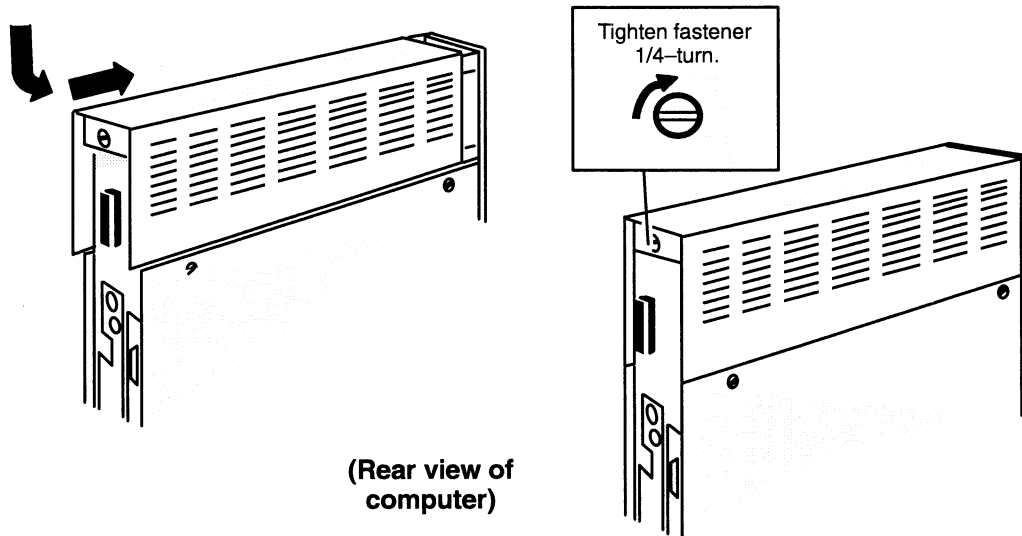

Figure 6-9 Installing the Top Cover

Installing the Side Covers

After installing the top cover, follow the steps below to reinstall one or both side covers. You will need a coin or a large flat-blade screwdriver.

1. If you have not done so already, remove the ESD clip from the computer unit and take off the ESD wrist strap. Store the wrist strap in a safe place for future use.
2. Insert the three tabs on the cover's bottom edge into the slots at the base of the computer unit as shown in Figure 6-10.

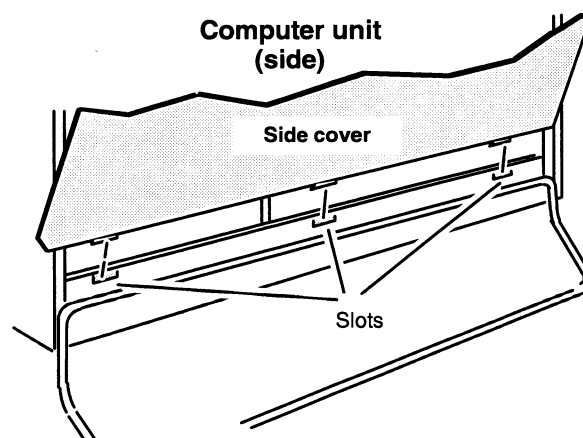

Figure 6-10 Inserting the Cover Tabs into the Computer Unit Slots

3. Rotate the cover as shown in Figure 6-11 so that it is against the side of the computer unit.

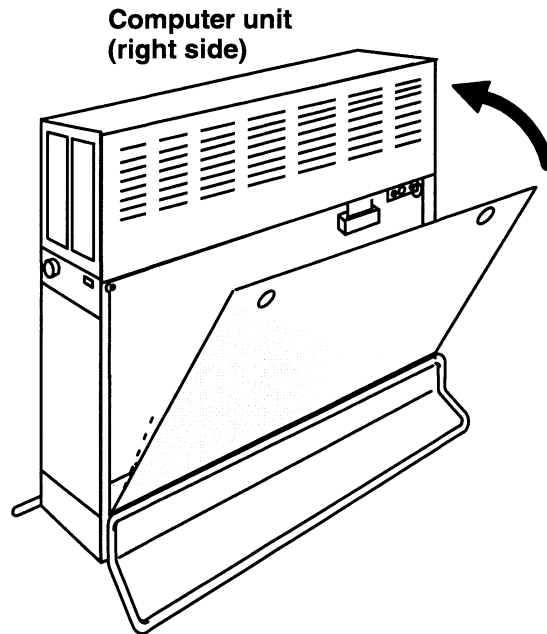

Figure 6-11 Installing the Side Covers

4. Using a coin or screwdriver, turn the two fasteners one-quarter turn clockwise as shown in Figure 6-12 to lock the cover in place.

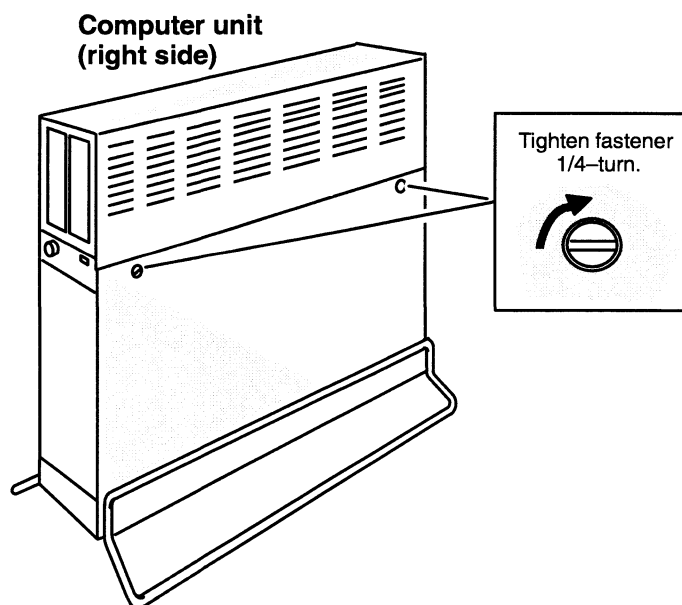

Figure 6-12 Tightening the Side Cover Fasteners

5. If you moved the computer, return it to its original position being careful not to strain the cables or jar the computer.

6. Plug the power cord into the receptacle on the back of the computer unit as shown in Figure 6-13.

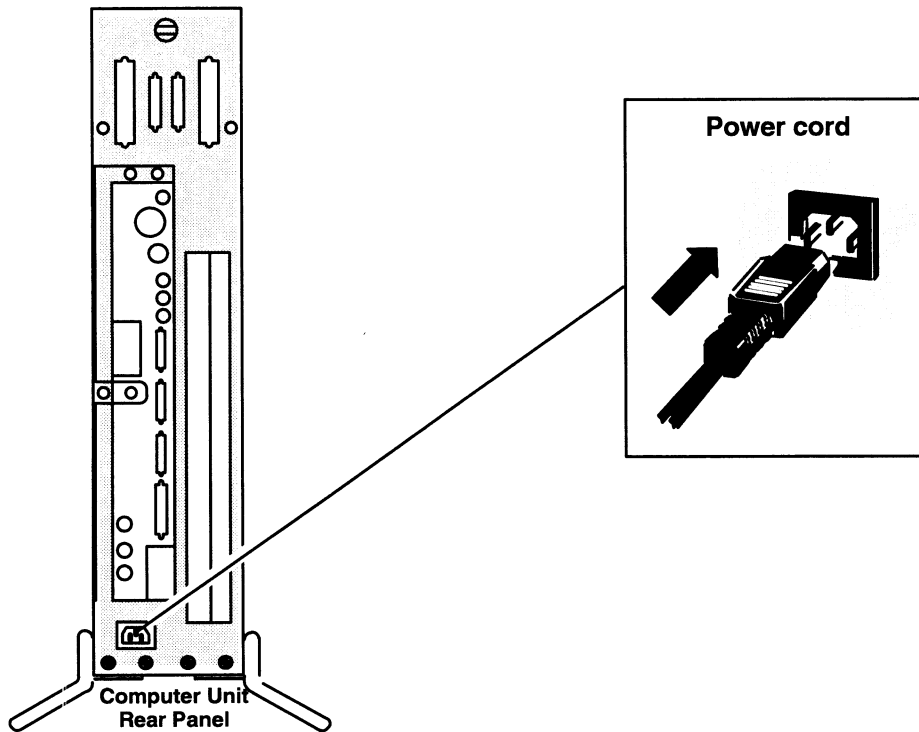

Figure 6-13 Connecting the Computer Unit's Power Cord

7. Plug the other end of the power cord into the installation site's ac power outlet.

End of Chapter

Chapter 7

Adding or Replacing Internal Mass–Storage Devices

This chapter describes how to install new mass–storage drive options such as Winchester disks, tape drives, diskette drives, or CD-ROM drives inside your AViiON 530 or 4600 computer unit. It also provides directions for replacing failed internal mass–storage devices. For information on installing external devices to your system, refer to the documentation that accompanied the external subsystem or independent device.

To install or replace a drive, you will need device–specific information not provided in this manual. Make certain you have the appropriate documentation to set jumpers and operating parameters on each individual drive you need to configure or reconfigure. *Guide to AViiON® and DG/UX™ System Documentation* lists the manuals that support the mass storage devices available in AViiON 530 and 4600 series systems.

NOTE: *Before* you add or replace any mass storage device, refer to Chapter 4, “Setting Up and Installing a SCSI Bus,” and Chapter 6, “Expanding and Maintaining Your Computer System,” to plan or verify your configuration.

Supported Mass–Storage Devices

An integrated Small Computer Systems Interface (SCSI) bus controller supports all the mass–storage devices housed inside your computer unit. Each SCSI controller in your system can support up to seven devices or adapters, but a maximum of four devices will fit inside an AViiON 530 or 4600 series computer unit chassis. Since tape, diskette, and CD-ROM drives require access from the front, only two of the internal drives can use removable media. Disk drives can occupy all four internal mass–storage spaces.

Table 7-1 lists the internal mass–storage devices supported by AViiON 530 and 4600 series systems.

Table 7-1 AViiON 530 and 4600 Series Internal Mass-Storage Drives

Drives	Model	Size
Disks		
332-Mbyte Winchester	6662	Half-height ¹
520-Mbyte Winchester	6796	Half-height ¹
662-Mbyte Winchester	6554	Full-height
1-Gbyte Winchester	6685	Full-height
1.4-Gbyte Winchester	6716	Full-height
Removable Media		
2-Gbyte tape	6590	Full-height
525-Mbyte QIC tape	6677	Half-height
150-Mbyte QIC tape	6577	Half-height
1.44-Mbyte diskette	6562	Half-height
1.2-Mbyte diskette	6563	Half-height
CD-ROM	6629	Half-height
Digital audio tape	6762	Half-height

¹ Some versions include 3 1/2- to 5 1/4-inch conversion brackets

Mass-Storage Device Locations

Your computer unit has the two slots for internal SCSI drives as shown in Figure 7-1. Each slot can hold one drive assembly that contains two brackets and either one full-height drive or two half-height drives.

NOTE: Drives are mounted vertically in the computer unit. A full-height drive mounted vertically is 3.25 inches wide, and a half-height drive mounted vertically is 1.75 inches wide.

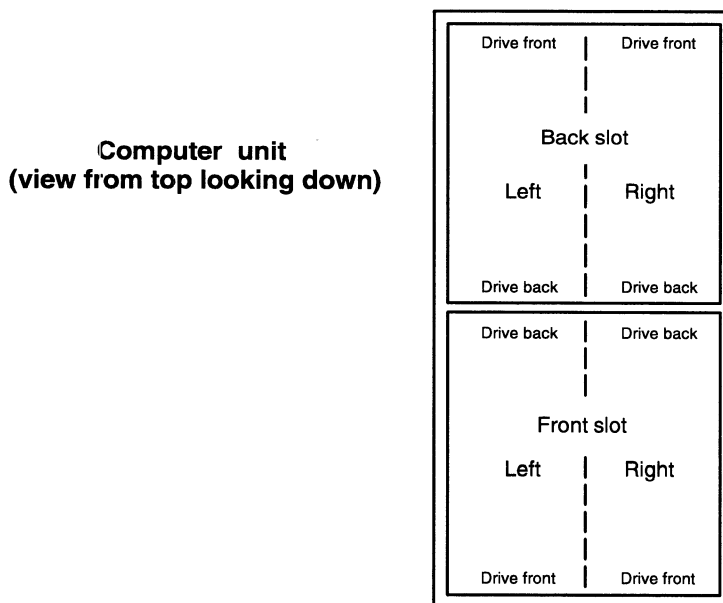

Figure 7-1 Internal Drive Slots

Either drive slot can hold one drive assembly containing either one full-height drive or one or two half-height drives.

- If you are adding a removable media drive you must assign it to an available space in the front slot.
- If you are adding a disk drive, assign it to an available space in the back slot. If there is no available space in the back slot, then assign it to a space in the front slot.

To add a new internal drive option, you need to perform the following tasks:

1. Identify where to install the drive.
2. If you are adding the drive to an existing drive assembly (drive and two brackets), remove the drive assembly from the computer unit.
3. Configure the new drive.
4. Attach the brackets to the new drive.
5. (Re)install the drive assembly in the computer unit.

To replace a failed internal drive, you need to perform the following tasks:

1. Remove the drive assembly containing the failed drive from the computer unit.
2. Remove the brackets from the failed drive.
3. Configure the replacement drive.
4. Attach the brackets to the replacement drive.
5. Reinstall the drive assembly in the computer unit.

Removing a Drive Assembly

Before you can remove a drive assembly, you should remove the computer unit's top and side covers and attach the ESD wrist strap as described in Chapter 6, "Expanding and Maintaining Your Computer System."

CAUTION: *Unless you are properly grounded, you can discharge static electricity and damage components in the system.*

To remove the drive assembly from the computer unit, follow the steps below. A drive assembly consists of two drive brackets and one or two drives. You will need a medium (#2) Phillips screwdriver.

1. Unplug the power and SCSI bus cables from the drive. If the drive assembly contains two half-height drives, unplug the cables from each drive. Figure 7-2 shows the internal drive ribbon cable and power connectors.
2. If you are removing a diskette drive, unplug the I/O bus cable from the diskette drive you are removing as shown in Figure 7-3.
3. Next unplug the power adapter cable from the diskette drive you are removing as shown in Figure 7-4.

For more information on cable connections, refer to the manual listed in *Guide to AViiON® and DG/UX™ Systems Documentation* for installing the drive.

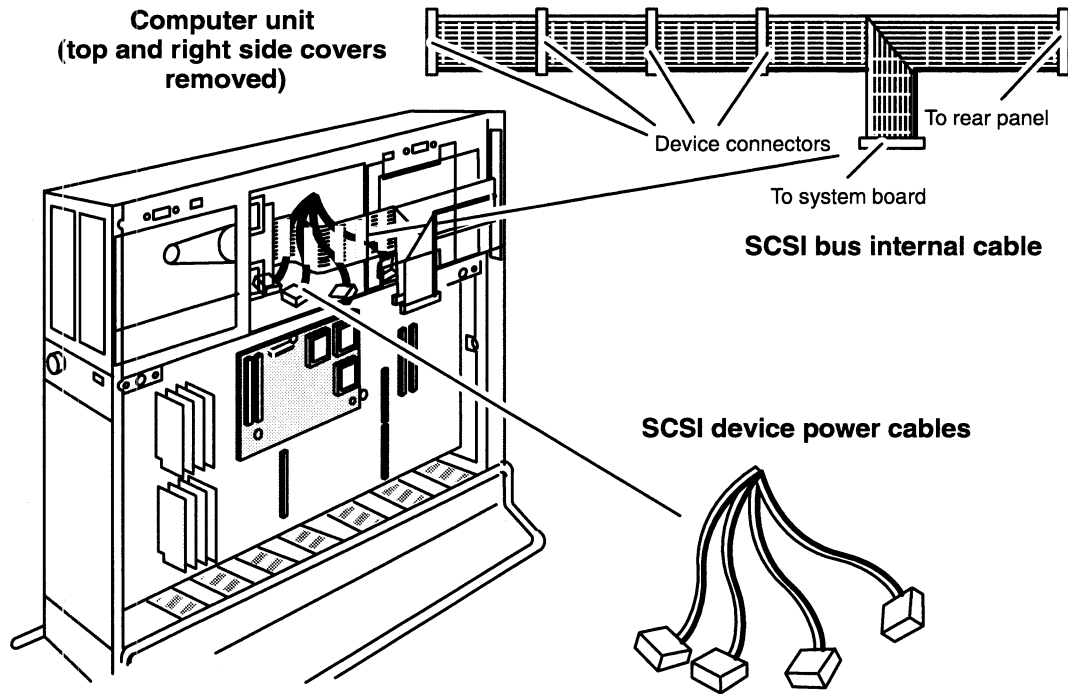

Figure 7-2 SCSI Bus Ribbon Cable and Device Power Connectors

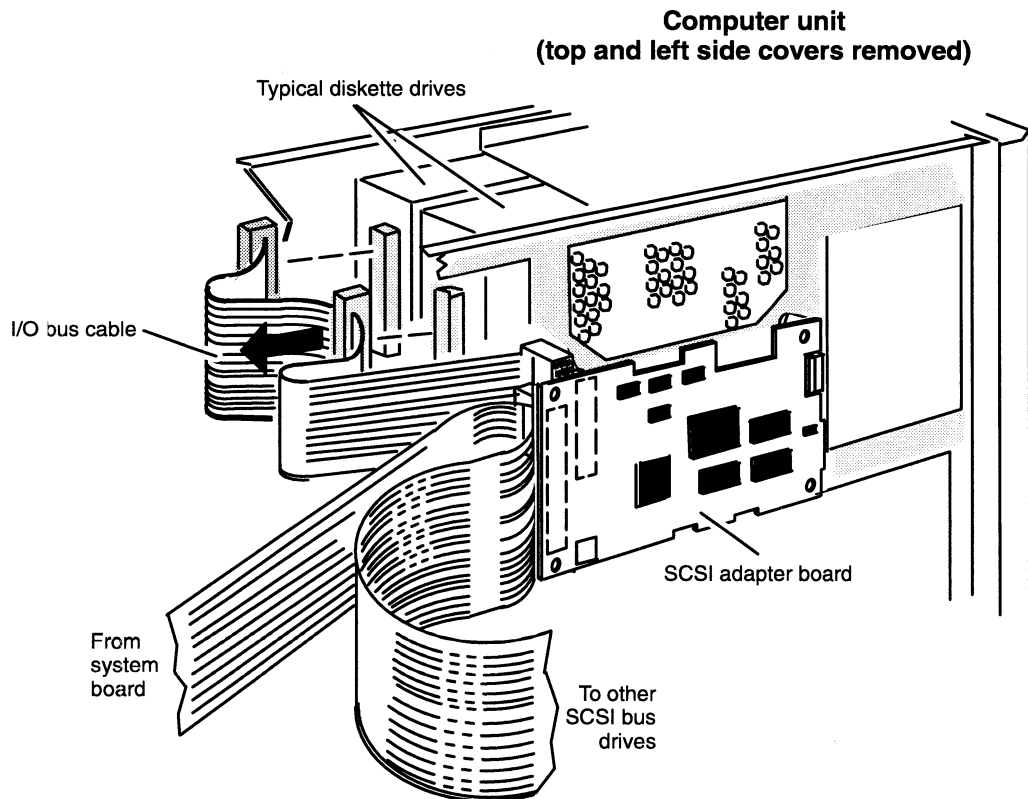

Figure 7-3 Unplugging the I/O Bus Cable from a Diskette Drive

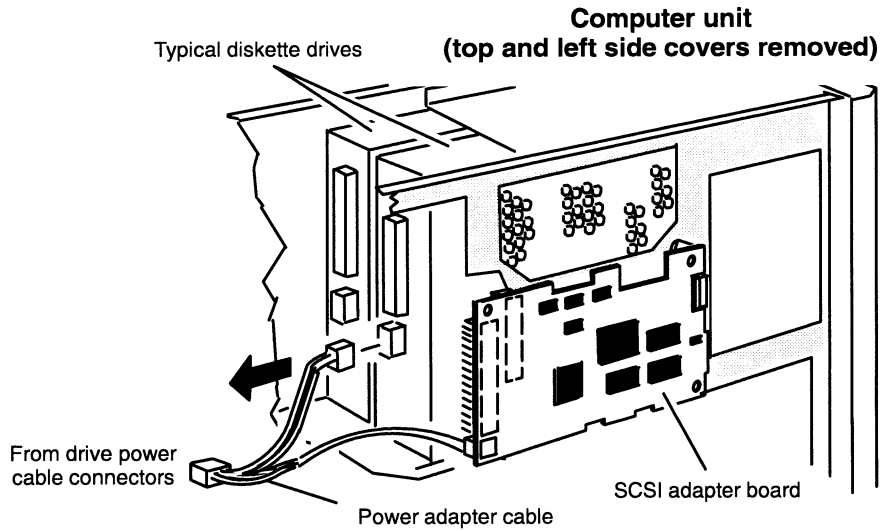

Figure 7-4 Unplugging the Power Adapter Cable from a Diskette Drive

4. Remove the eight screws and washers securing the drive assembly to the computer unit as shown in Figure 7-5.

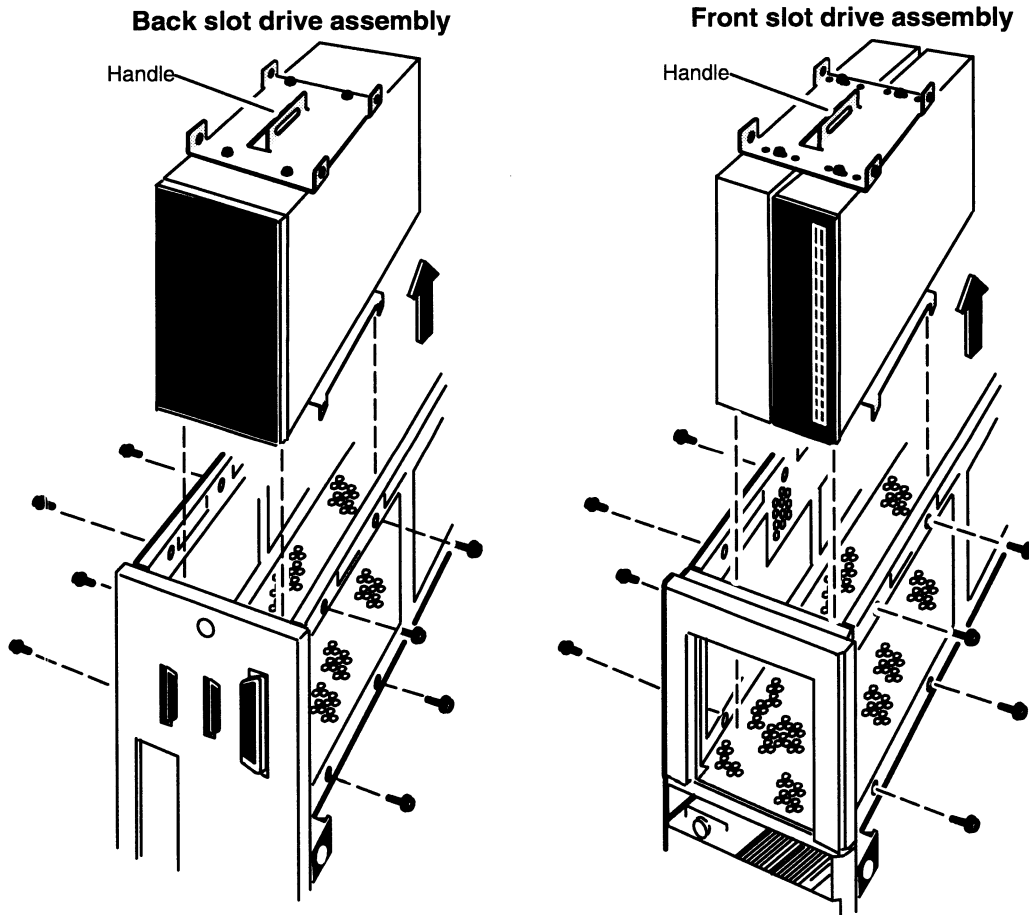

Figure 7-5 Removing a Drive Assembly from the Computer Unit

5. Use the handle on the drive assembly to lift the drive assembly out of the computer unit. If you are removing a drive assembly from the front slot, slide the assembly toward the center of the computer unit first; then lift it out of the computer unit.

If you are removing a drive from the drive assembly, go to the next section. If you are adding a drive to the drive assembly, go to the “Configuring New or Replacement Drives” section.

Removing Brackets from a Drive

To remove the brackets from the drive you are replacing, follow the steps below. You will need a medium (#2) Phillips screwdriver.

1. Remove the eight screws and washers (four for each bracket) that secure the drive to the brackets.

If the drive assembly contains two half-height drives and you want to detach just one half-height drive from the brackets, remove only the four screws and washers that attach that drive to the brackets. There is no need to detach the other half-height drive from the brackets. Figure 7-6 shows how to remove the brackets from full-height and half-height drives.

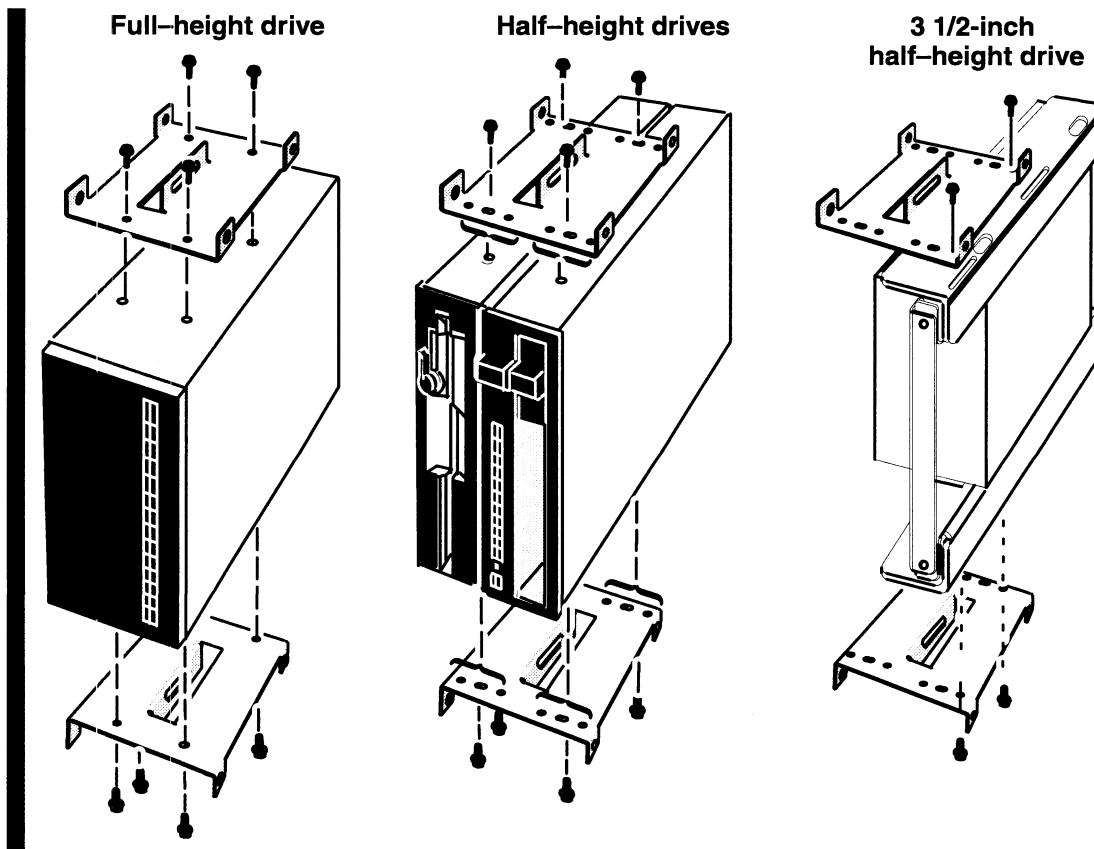

Figure 7-6 Removing Brackets from Drives

2. Grasping the drive by its edges, gently place the drive and brackets on a work surface.

If you removed a failed drive, insert it in an antistatic bag and return it to Data General. Contact Data General, as described in the Preface, for information on returning the faulty part.

To install a replacement drive, go to the next section, “Configuring New or Replacement Drives ”

Configuring New or Replacement Drives

Before you install a new or replacement drive in your system, you must *configure* the drive to cooperate with your other system components. In particular, you need to set the operating parameters for your SCSI drives to function properly with other devices on the SCSI bus. Once you have confirmed (after referring to Chapters 6 and 4 in this manual) that your new drive adheres to the SCSI and power rules for your entire system, you must set the appropriate jumpers and/or switches on the new or replacement drives as described in this section.

NOTE: For information on how to access the SCSI jumpers/switches and the terminator resistors, refer to the manual on installing the drive listed in *Guide to AViiON® and DG/UX™ Systems Documentation*.

Configure the new or replacement drive as follows:

- On the disks, set the spindle control option jumpers or switches for sequential drive motor start. The drive will then delay starting up its spindle motor a number of seconds (a multiple of the SCSI ID number) when you power up your system.
- Set the appropriate jumpers or switches for the SCSI bus (host system) to provide terminator power rather than the drive itself. Some devices specify this option as “SCSI pin 26 ON,” or “power from interface cable pin 26.”
- Set the jumpers or switches to *enable* parity checking and arbitration if the drive offers these options.
- Make sure the bus termination is correct on the new drive. In an AViiON 530 or 4600 series computer, *all* the internal drives and SCSI adapter boards must have their SCSI bus terminator resistors *removed*.
- Set the SCSI ID jumpers or switches on the new drive or SCSI adapter board to the device ID you assigned it when you planned your SCSI bus. Table 7-2 reviews the device identification sequence we recommend; Figure 7-7 shows an example of a valid SCSI bus configuration.

NOTE: You should review or complete the SCSI Bus Configuration Worksheet in Chapter 4 to see if any external SCSI drive or SCSI adapter board on the first (connector “A”) bus has the same SCSI ID as the internal drive or SCSI adapter board you intend to add. If any external device on the bus has the same SCSI ID as an internal drive or SCSI adapter board, you must reassign your SCSI IDs for one of the devices.

Table 7-2 SCSI Device Identification Numbers

Drives ¹	ID Number	LUN
Disk Drives		
First drive	0	
Second drive	1	
Third drive	2	
Diskette Drives		
Adapter board	3 ²	
First drive		0
Second drive		1
Tape Drives		
First drive	4	
Second drive	5	
Third drive	6	

¹ A CD-ROM drive can have any SCSI ID except 0 or 4.

■ ² Or as the next "disk" in sequence.

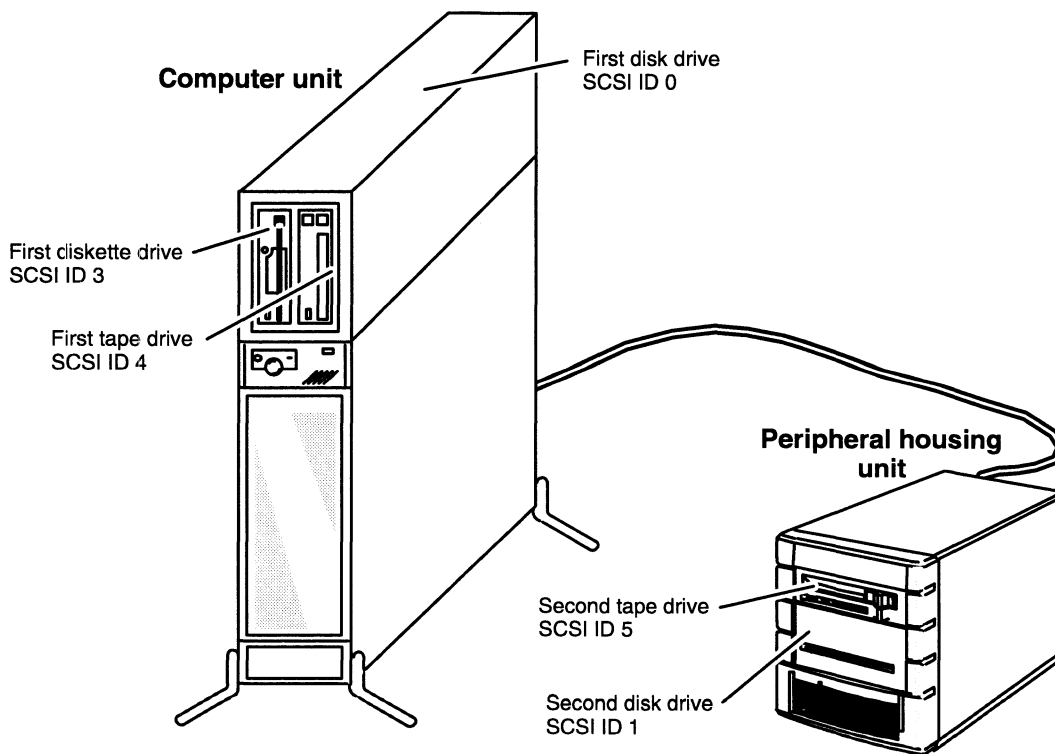

Figure 7-7 Example of Recommended SCSI ID Settings

Continue with the next section to install your properly configured drive in the computer chassis.

Installing a Drive Assembly

After you configure your new or replacement drive, you can attach the brackets to form a drive assembly, and then (re)install the assembly into your computer chassis.

Attaching Brackets to a Drive

To attach the brackets to the new drive, follow the steps below. You will need a medium (#2) Phillips screwdriver.

1. Grasping the new drive by its edges, align the appropriate mounting holes in the bracket with the holes in the side of the drive. A half-height drive fills half of the bracket. Figure 7-8 shows the mounting holes for for each type of drive.

Drive mounting bracket

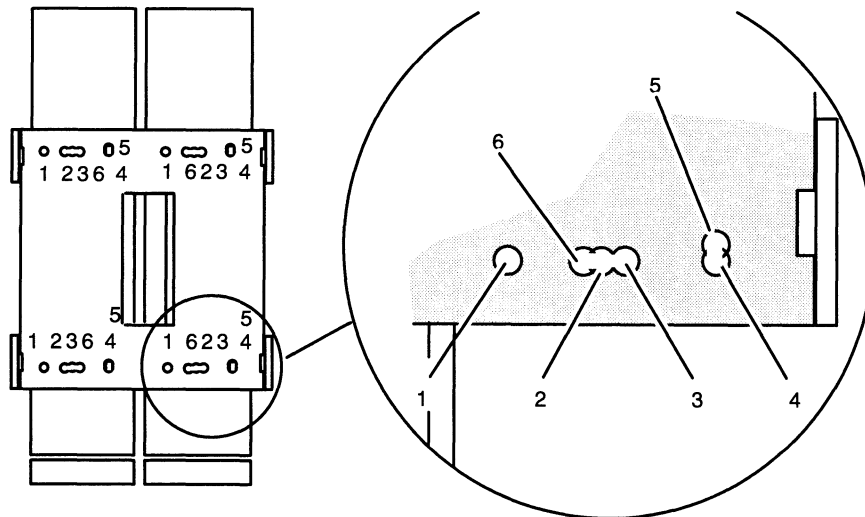

Half-Height Drives	Mounting Hole Numbers
332-Mbyte disk	2 or 4 ¹
520-Mbyte disk	4 ¹
600-Mbyte CD-ROM	2
150-Mbyte QIC cartridge tape	1
525-Mbyte QIC cartridge tape	5
1.2-Mbyte diskette	2
1.44-Mbyte diskette	4
Digital audio tape	4
Full-height Drives	Mounting Hole Numbers
2-Gbyte tape	6
1-Gbyte disk	6
1.4-Gbyte disk	6
662-Mbyte disk	6

¹ Mounts to 3 1/2- to 5 1/4-inch conversion brackets

Figure 7-8 Bracket Mounting Holes for Drives

2. Attach the two brackets to the new drive with the eight mounting screws and washers (four for each bracket) as shown in Figure 7-9. If you are adding only one half-height drive to the brackets, you need to use only four screws and washers (two for each bracket).

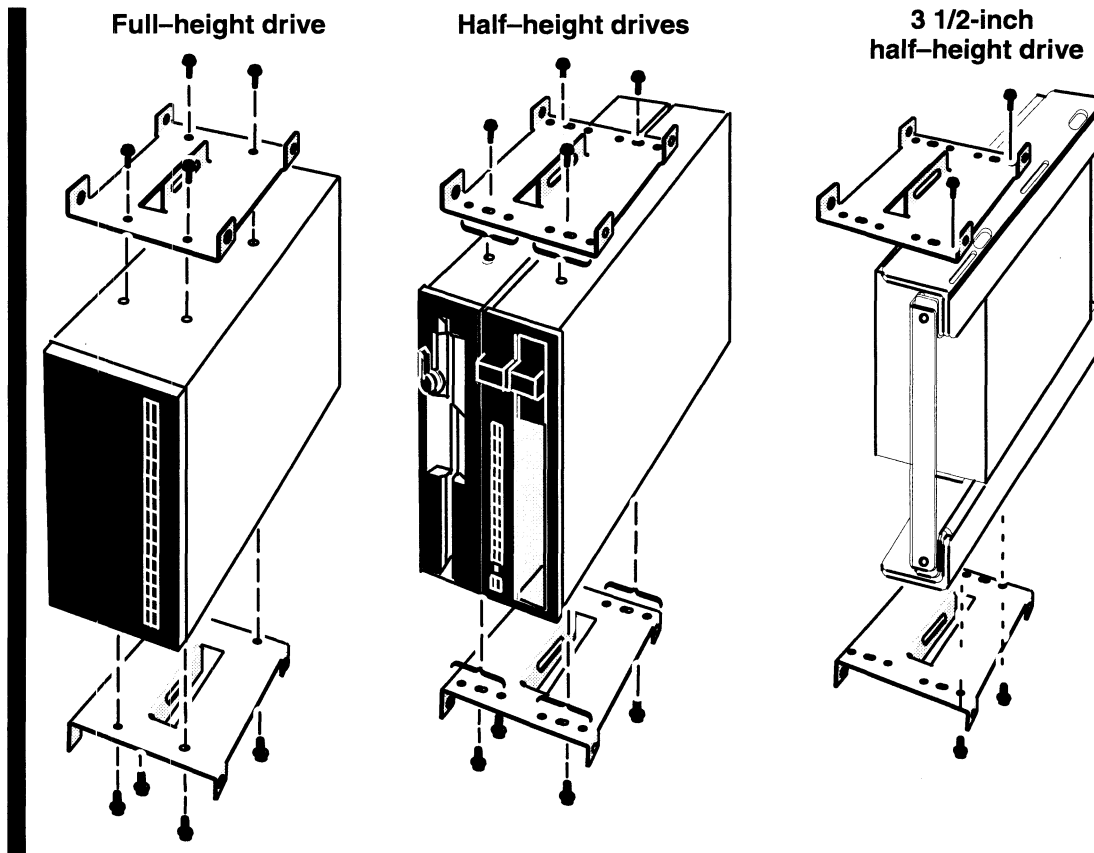

Figure 7-9 Attaching Brackets to Drives

Now go to the next section, “Completing the Drive Assembly Installation,” to complete the installation of the drive.

Completing the Drive Assembly Installation

To complete the installation of the drive, follow the steps below. You will need a medium (#2) Phillips screwdriver, and in some cases, a small flat-blade screwdriver. If you are installing a removable media drive, start with Step 1; otherwise, start with Step 2.

1. If you are installing a removable media drive, look at the computer unit’s front panel. If the slot where you are installing the drive has a plastic filler panel, you must remove the panel as described below. Figure 7-10 shows a filler panel covering the right front slot.

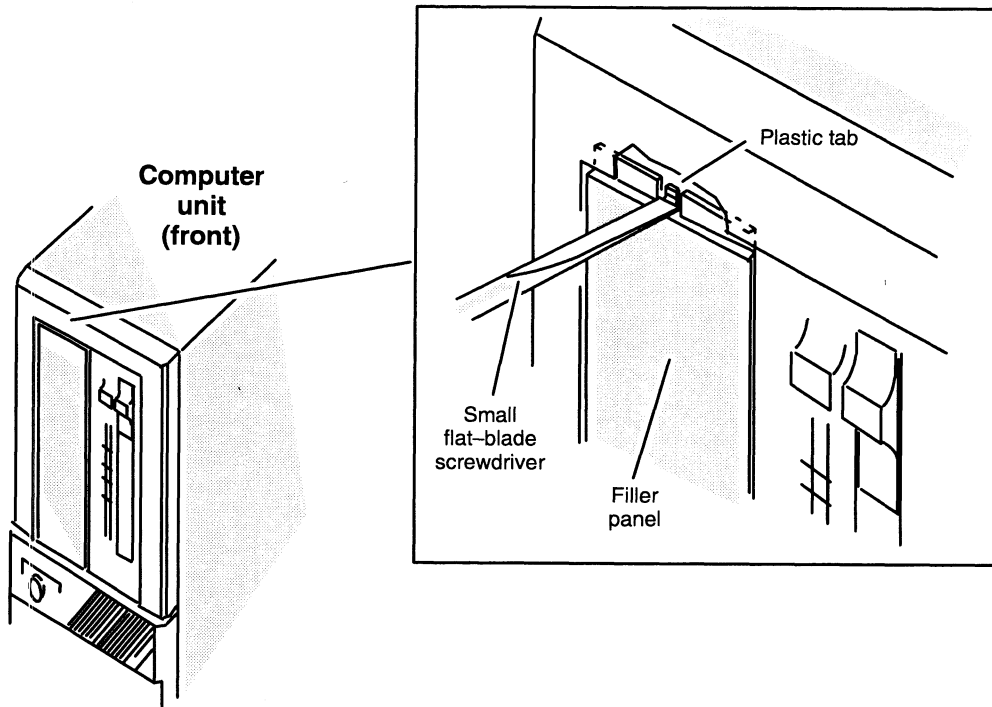

Figure 7-10 Removing or Replacing a Filler Panel

While supporting the filler panel, insert the tip of a flat-blade screwdriver about 1/8-inch into the recessed slot and gently twist the screwdriver to release the plastic tab on the filler panel. Once you do this the filler panel will pop out.

2. Position the drive in the slot so that its back (connector end) faces toward the center of the computer unit. If you are installing a drive assembly in a front slot, slide the drive into the front panel opening.
3. Align the holes on the drive assembly's brackets with the holes in the computer unit frame, and attach the drive assembly to the computer unit with the eight screws and washers as shown in Figure 7-11.

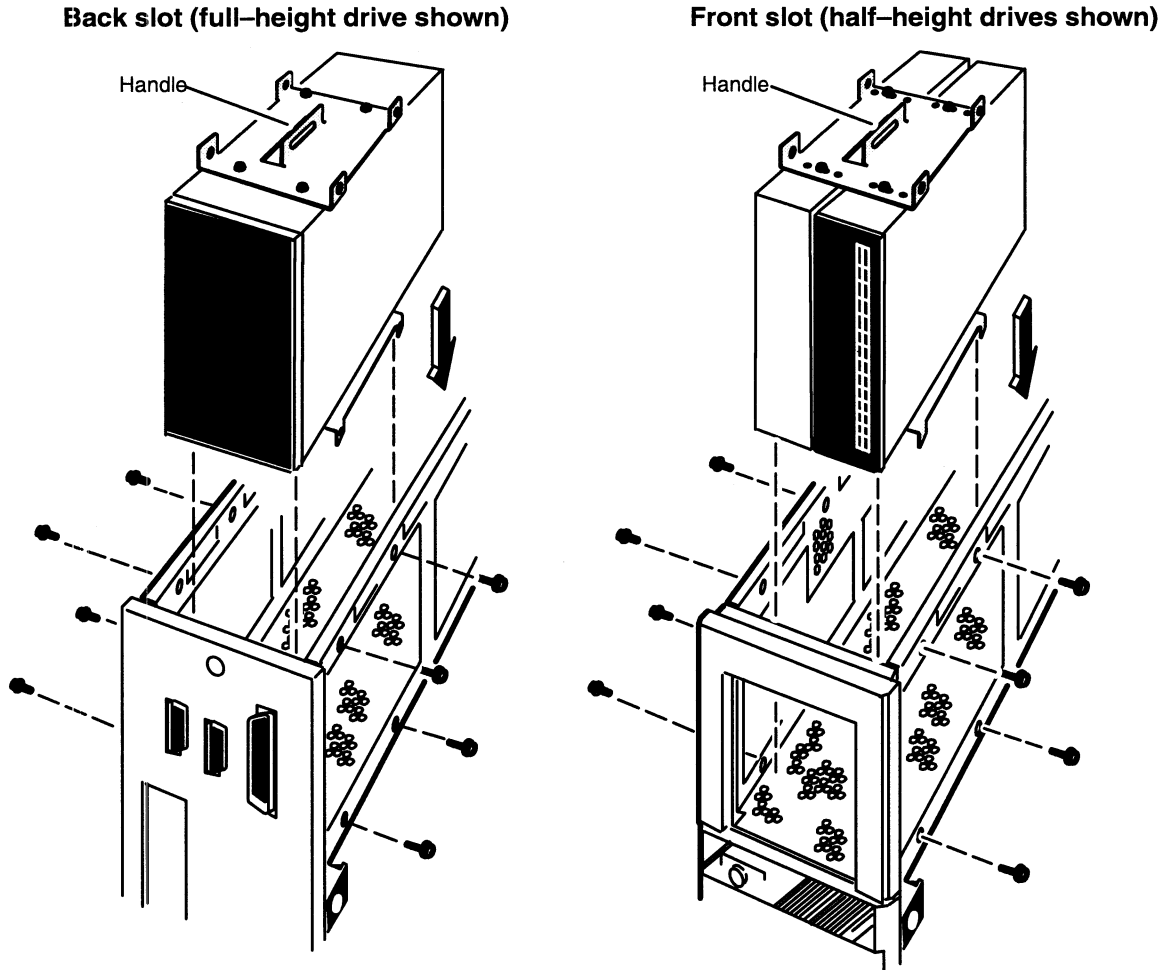

Figure 7-11 Installing a Drive Assembly in the Computer Unit

4. Plug a power cable and the nearest SCSI bus cable connector firmly into the power and SCSI bus connectors on each drive in the drive assembly. For information on the connector locations, refer to the manual for installing the drive.

NOTE: You can plug the cable in only one way: the connector on the power cable has beveled edges to match the power connector on the drive; the connector on the SCSI cable is keyed.

If you are installing a diskette drive, plug the power adapter cable into the diskette drive you are installing as shown in Figure 7-12.

Next, plug the I/O bus cable into the diskette drive you are installing as shown in Figure 7-13. Be sure to plug in the cable so that the red line is on the bottom.

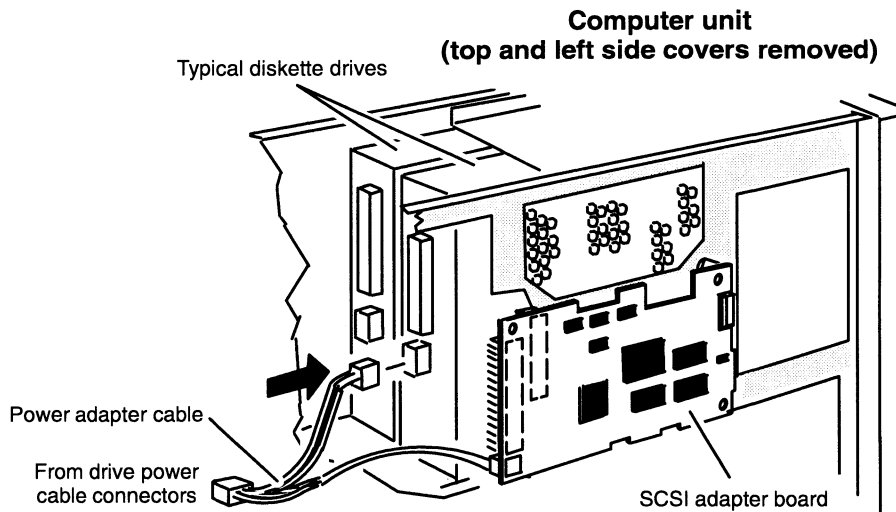

Figure 7-12 Plugging the Power Adapter Cable into a Diskette Drive

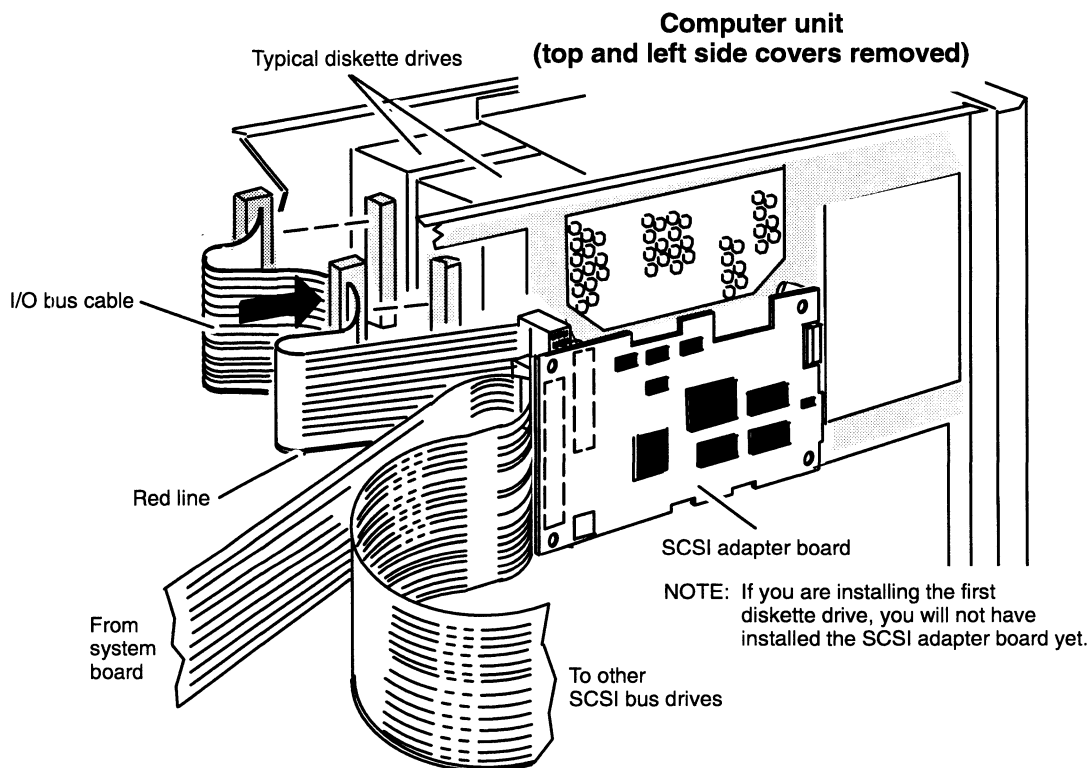

Figure 7-13 Plugging the I/O Bus Cable into a Diskette Drive

If you installed the *first* diskette drive in your computer chassis, go to the “Adding or Replacing the SCSI Adapter Board” section of this chapter to install the SCSI adapter board. If you are installing a drive other than the first diskette drive, you have now completed the procedure for installing a drive. You should remove the ESD wrist strap, reinstall the top and side covers, and plug in the computer unit’s power cord as described in the “Closing the Computer Unit” section of Chapter 6.

After you have closed the computer unit, you should power up any peripheral housing units and other peripherals, and then the computer, according to the instructions in the “Powering Up” section of Chapter 3. Then test your computer system by running the AViiON System Diagnostics as described in the *Using AViiON® System Diagnostics* manual.

Adding or Replacing the SCSI Adapter Board

The diskette drives supported in AViiON 530 and 4600 series systems require a printed-circuit board that adapts the SA450-interface diskette drive to the system’s SCSI bus. One of these *SCSI adapter boards* can support two diskette drives.

If you are adding the SCSI adapter board, go to the section, “Installing the SCSI Adapter Board.” If you are replacing the SCSI adapter board, continue to the next section, “Removing the SCSI Adapter Board.”

Removing the SCSI Adapter Board

Before you can remove the SCSI adapter board, you should remove the computer unit’s top and side covers and attach the ESD wrist strap as described in Chapter 6, “Expanding and Maintaining Your Computer System.”

CAUTION: *Unless you are properly grounded, you can discharge static electricity and damage components in the system.*

To remove the SCSI adapter board from the computer unit, use the following steps.

1. Unplug the SCSI bus and I/O bus cables from the SCSI adapter board as shown in Figure 7-14.

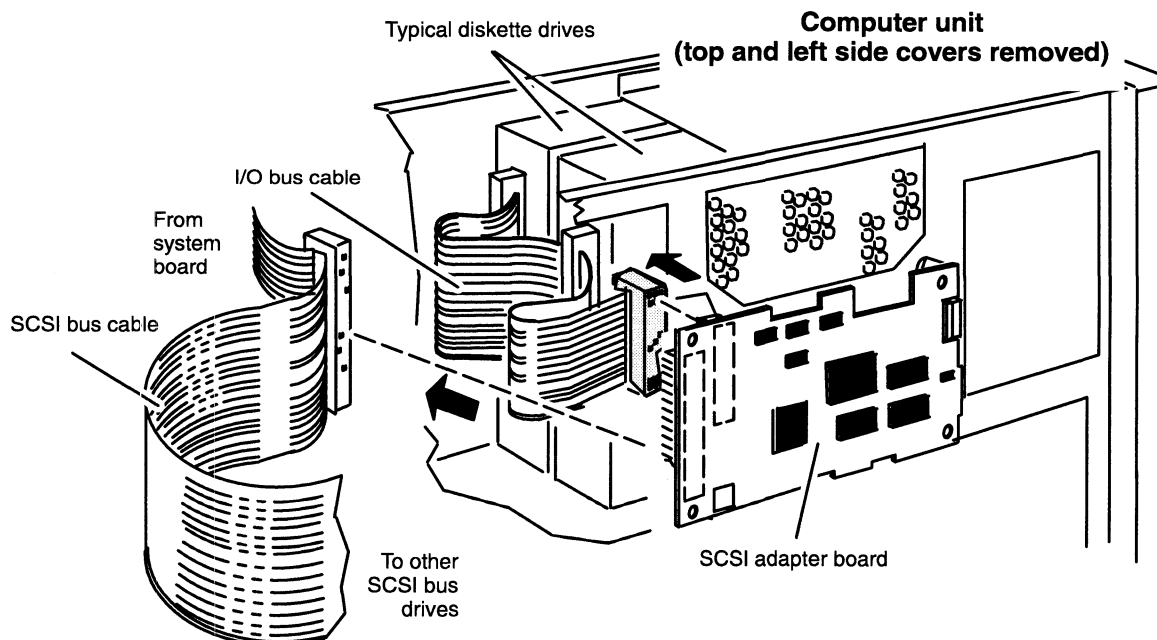

Figure 7-14 Unplugging the SCSI Bus and I/O Bus Cables from the SCSI Adapter Board

2. Unplug the power adapter cable from the SCSI adapter board as shown in Figure 7-15.

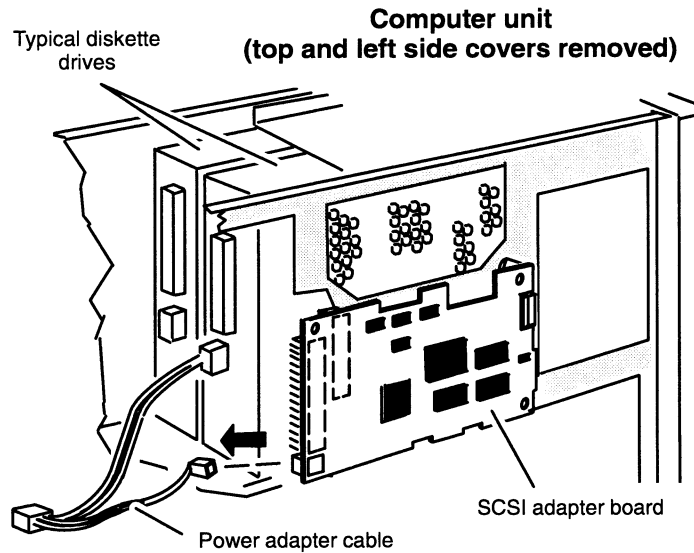

Figure 7-15 Unplugging the Power Adapter Cable from the SCSI Adapter Board

3. Remove the two screws securing the SCSI adapter board to the front of the left side of the computer unit as shown in Figure 7-16.

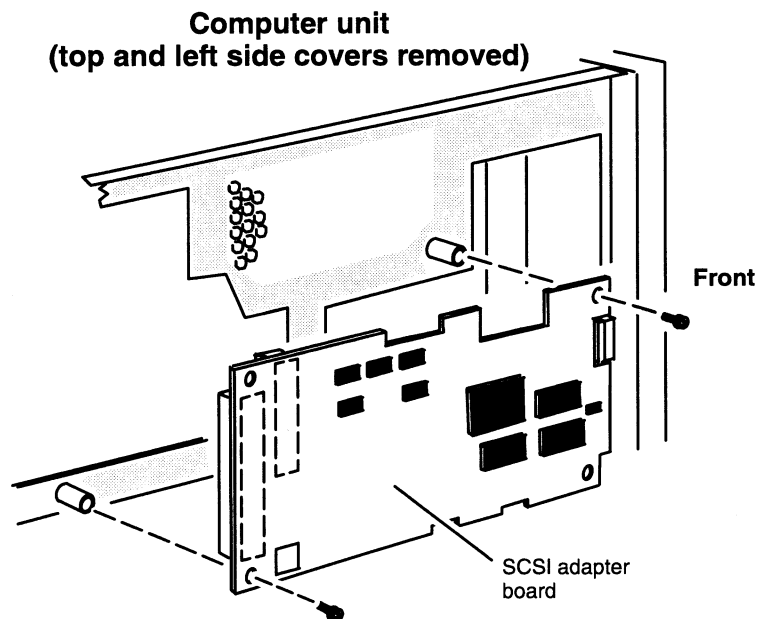

Figure 7-16 Removing or Installing SCSI Adapter Board Screws

If you removed a failed SCSI adapter board, insert it in an antistatic bag and return it to Data General. Contact the Customer Support Center, as described in the Preface, for information on returning the faulty part.

Installing the SCSI Adapter Board

Before you can install a new SCSI adapter board, you should remove the computer unit's top and side covers and attach the ESD wrist strap as described in the "Opening the Computer Unit" section of Chapter 6. You also need to prepare the SCSI adapter board as described in the device-specific manual(s) for the board and diskette drives.

CAUTION: *Unless you are properly grounded, you can discharge static electricity and damage components in the system.*

To install the SCSI adapter board in the computer unit, follow the steps below.

1. Prepare the board by setting the SCSI ID jumpers to specify drive 3.
2. Attach the SCSI adapter board to the computer unit with the two screws. Refer to Figure 7-16.
3. Plug the power adapter cable into the SCSI adapter board as shown in Figure 7-17.

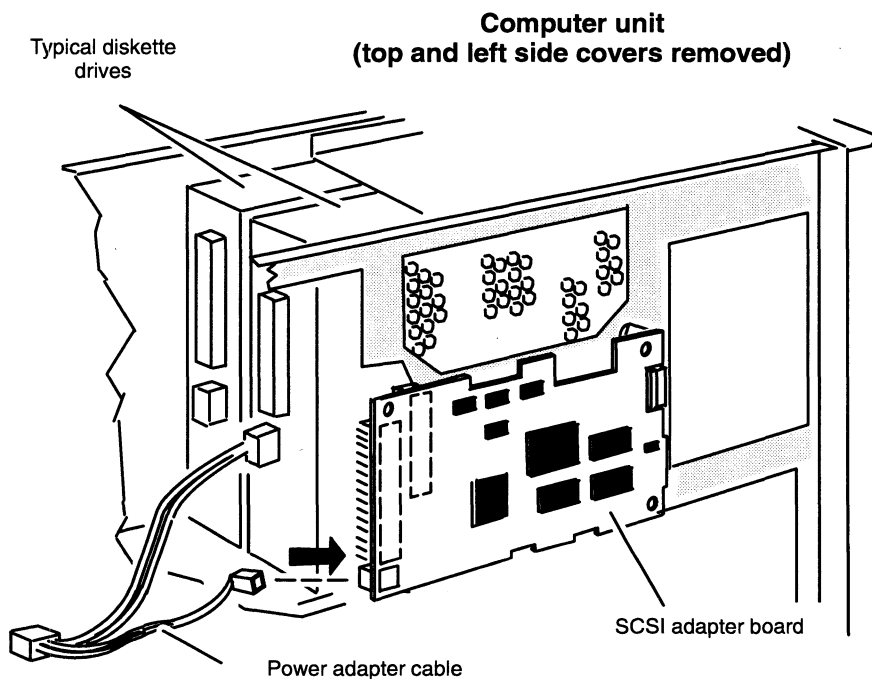

Figure 7-17 Plugging the Power Adapter Cable into the SCSI Adapter Board

4. Plug the SCSI bus and the I/O bus cables into the SCSI adapter board as shown in Figure 7-18. Be sure to plug in each cable so that the red line is on the bottom.

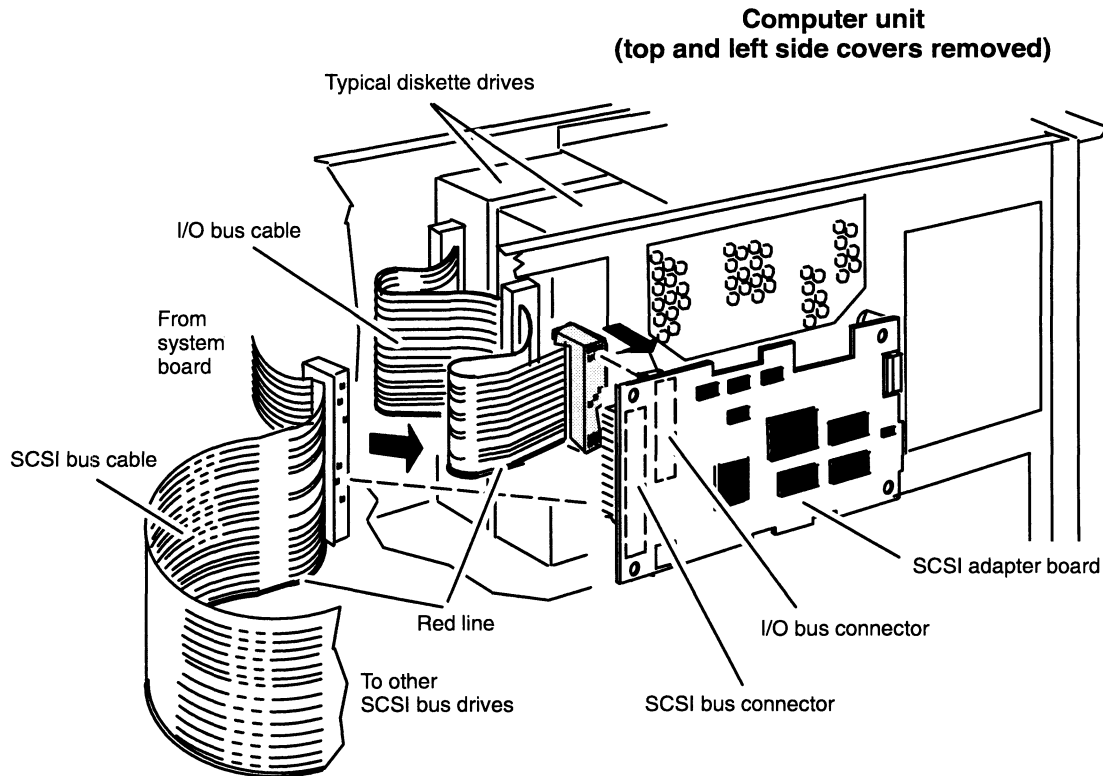

Figure 7-18 Plugging the SCSI Bus and I/O Bus Cables into the SCSI Adapter Board

5. Reinstall the top and side covers as described in the section, “Closing the Computer Unit” in Chapter 6.

Replacing the Terminator Plug

The computer uses a SCSI bus terminator plug that ships installed in the external SCSI connector(s) on the rear panel. If you have any external mass-storage devices, you must install the terminator plug on the *last* subsystem or independent device on each SCSI bus in your system. Refer to Chapter 4, “Setting Up and Installing a SCSI Bus,” for a description of SCSI bus configuration and termination rules.

To replace the terminator plug, follow the steps below.

1. If the computer subsystem is running, power it down. Refer to Chapter 3, “Starting and Stopping Your Computer System,” and your operating system software, for proper powerdown procedures.

2. Release the spring clips on each side of the terminator plug as shown in Figure 7-19, and unplug the terminator plug from the SCSI bus connector.

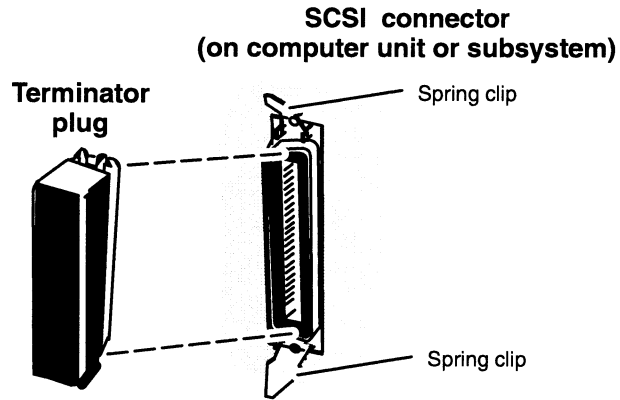

Figure 7-19 Unplugging and Plugging in the SCSI Bus Terminator Plug

3. Plug the new terminator plug into the same connector, and push the two spring clips down onto the new terminator plug to hold it in place.

End of Chapter

Chapter 8

Adding or Replacing Memory Modules

This chapter gives the rules for installing memory modules and explains how to add a new memory module or replace a failed one. You will need to remove memory modules to replace failed memory modules, or to replace a failed system board.

AViiON 530 and 4600 series computer systems support one to four pairs of Single In-Line Memory Modules (SIMMs). Model 7018 memory modules contain 4 megabytes of memory on each SIMM; Model 7019 modules provide 16 megabytes. Both models support Error Checking and Correction (ECC) rather than byte parity error detection. Figure 8-1 shows how to identify the memory modules supported by your system.

CAUTION: *Attempting to use improper memory modules may cause serious system damage. Make certain you have the correct model and part number SIMMs for your system before installation. Take particular care not to install byte parity memory modules in computers designed for ECC memory modules.*

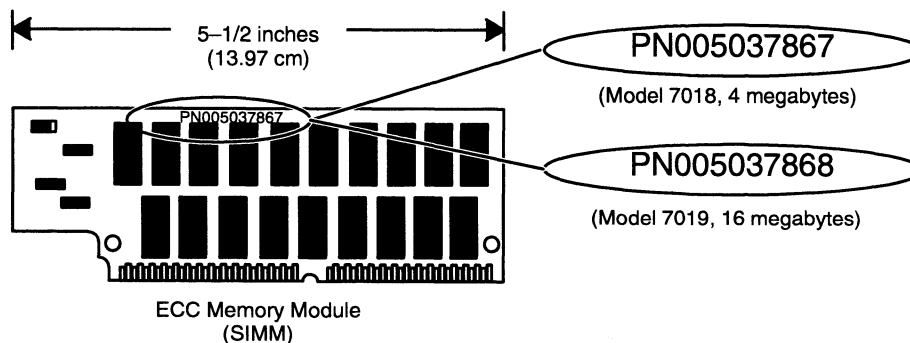

Figure 8-1 AViiON 530 and 4600 Series ECC Memory Modules

Each memory module mounts in a connector on the system board as shown in Figure 8-2.

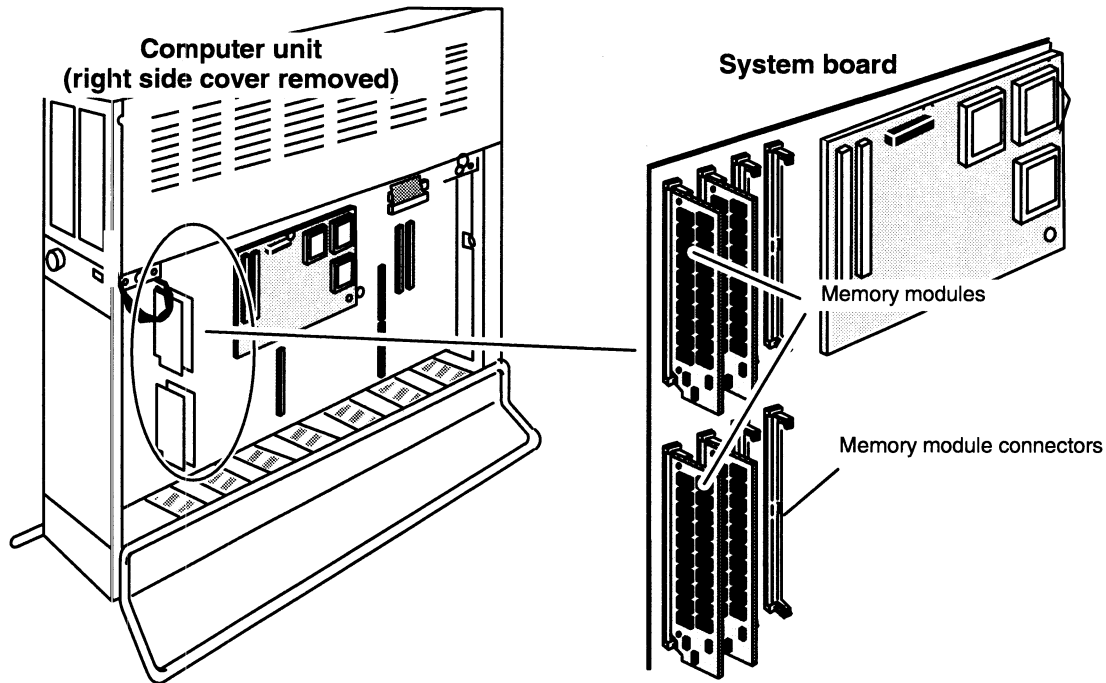

Figure 8-2 Location of Memory Modules and Connectors

Rules for Installing Memory Modules

When you install memory modules, you must follow the configuration and installation rules listed next. Note that Figure 8-3 shows the numbering scheme for AViiON 530 and 4600 series memory modules on the system board.

- You must install memory modules in *consecutive* memory module connector pairs, starting with the leftmost vertical pair (connector numbers 0 and 1) and working towards the right. Never leave a connector empty between memory modules.
- You must configure memory modules in vertical *pairs* on the system board. Odd numbers of modules will not work in AViiON 530 or 4600 series systems. For example, a module in connector 2 on the system board requires a memory module in connector 3; a memory module in connector 5 will not work without a corresponding module in connector 4.
- Each pair requires modules of equal capacity. For example, a 16-Mbyte memory module in connector 2 requires a 16-Mbyte module in connector 3.
- You must install all pairs of 16-Mbyte modules *first* (in the lower-numbered slots) when installing a mix of 4-Mbyte and 16-Mbyte modules. For example, in a configuration that combines two pairs of 16-Mbyte and one pair of 4-Mbyte memory modules, the 16-Mbyte pairs must occupy connectors 0-3 on the system board, and the 4-Mbyte modules must occupy connectors 4 and 5.

- If you are replacing a memory module, you must temporarily remove *all* the memory module(s) installed to the right of the one you are replacing, starting with the rightmost memory module and working toward the left.

For example, assume memory modules occupy connectors 0 through 7. You can remove the memory module in connector 3 only after connectors 5 and 7 are unoccupied. To replace the module in connector 3, you must first remove the memory module in connector 7, then the memory module in connector 5.

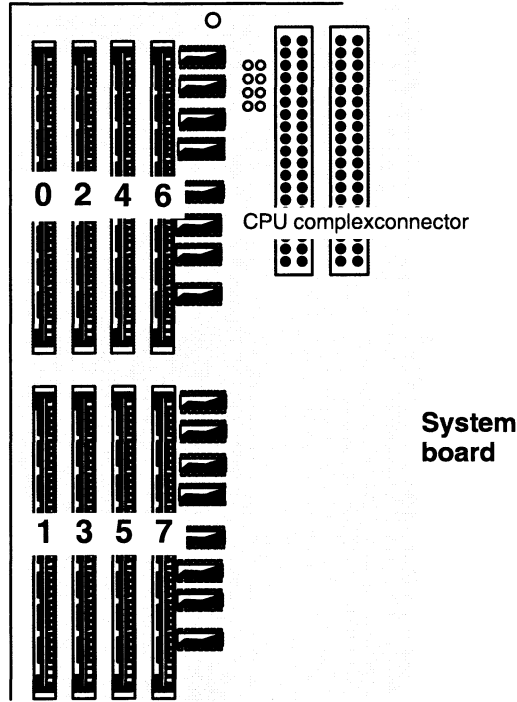

Figure 8-3 Numbering Scheme for Memory Module Connectors

Table 8-1 lists valid memory configurations for AViiON 530 and 4600 series systems.

Table 8-1 Valid Memory Configurations

Connector Number								Total Mbytes Memory
0	1	2	3	4	5	6	7	
4 Mb	4 Mb							8
4 Mb	4 Mb	4 Mb	4 Mb					16
4 Mb	4 Mb	4 Mb	4 Mb	4 Mb	4 Mb			24
4 Mb	4 Mb	4 Mb	4 Mb	4 Mb	4 Mb	4 Mb	4Mb	32
16 Mb	16 Mb							32
16 Mb	16 Mb	4 Mb	4 Mb					40
16 Mb	16 Mb	4 Mb	4 Mb	4 Mb	4 Mb			48
16 Mb	16 Mb	4 Mb	4 Mb	4 Mb	4 Mb	4 Mb	4Mb	56
16 Mb	16 Mb	16 Mb	16 Mb					64
16 Mb	16 Mb	16 Mb	16 Mb	4 Mb	4 Mb			72
16 Mb	16 Mb	16 Mb	16 Mb	4 Mb	4 Mb	4 Mb	4 Mb	80
16 Mb	16 Mb	16 Mb	16 Mb	16 Mb	16 Mb			96
16 Mb	16 Mb	16 Mb	16 Mb	16 Mb	16 Mb	4 Mb	4Mb	104
16 Mb	16 Mb	16 Mb	16 Mb	16 Mb	16 Mb	16 Mb	16Mb	128

If you need to remove a memory module, proceed to the next section. If you are adding a memory module in an empty connector, go to the section “Installing Memory Modules.”

Removing Memory Modules

Before you can remove any memory modules, you must remove the computer unit’s right side cover and attach the ESD wrist strap as described in the “Opening the Computer Unit” section of Chapter 6.

CAUTION: *Unless you are properly grounded, you can discharge static electricity and damage components in the system.*

To remove a memory module, follow the steps below.

NOTE: You must temporarily remove all memory module(s) installed to the right of the one you are replacing, starting with the rightmost memory module and working toward the left.

- Using your finger, gently push the locking tab on the *bottom* of the connector *down* as shown in Figure 8-4. Then gently push the locking tab on the *top* of the connector *up* as shown in Figure 8-4. The memory module will spring up slightly, indicating that the module is released.

CAUTION: *When you push on the locking tabs, push gently, using only enough force to release the memory module. If you push too hard, you could break the locking tabs, making it difficult for you to reinstall a memory module securely in the connector.*

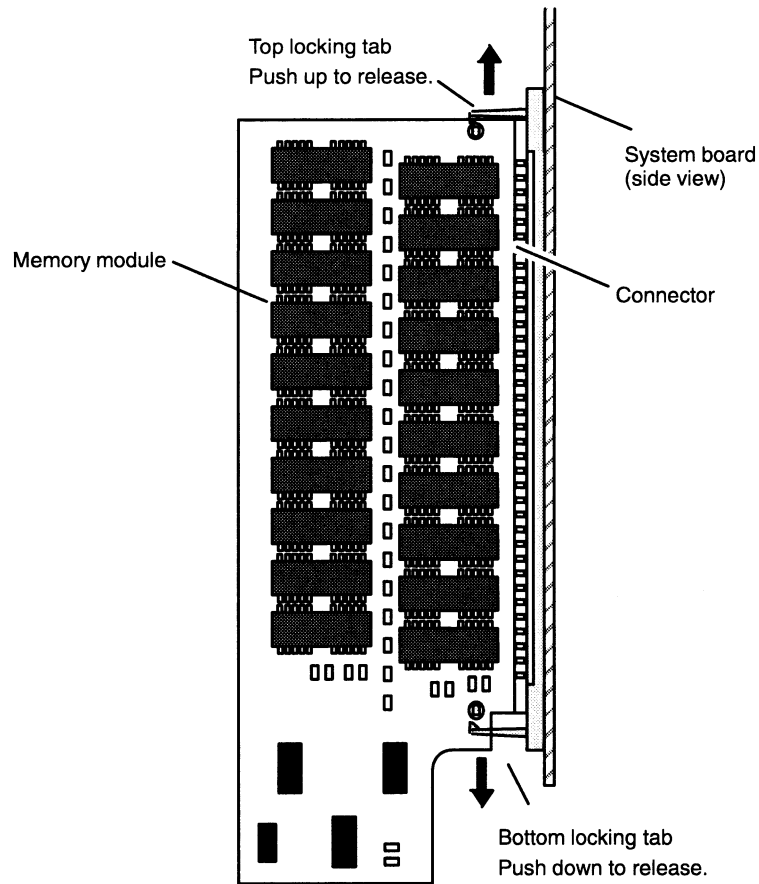

Figure 8-4 Releasing the Memory Module Locking Tabs

2. With the locking tabs released, raise the memory module to about a 20°—30° angle as shown in Figure 8-5, then *gently* pull the module from its connector.

CAUTION: *If you need to set the memory module down, put it back inside the antistatic shipping bag.*

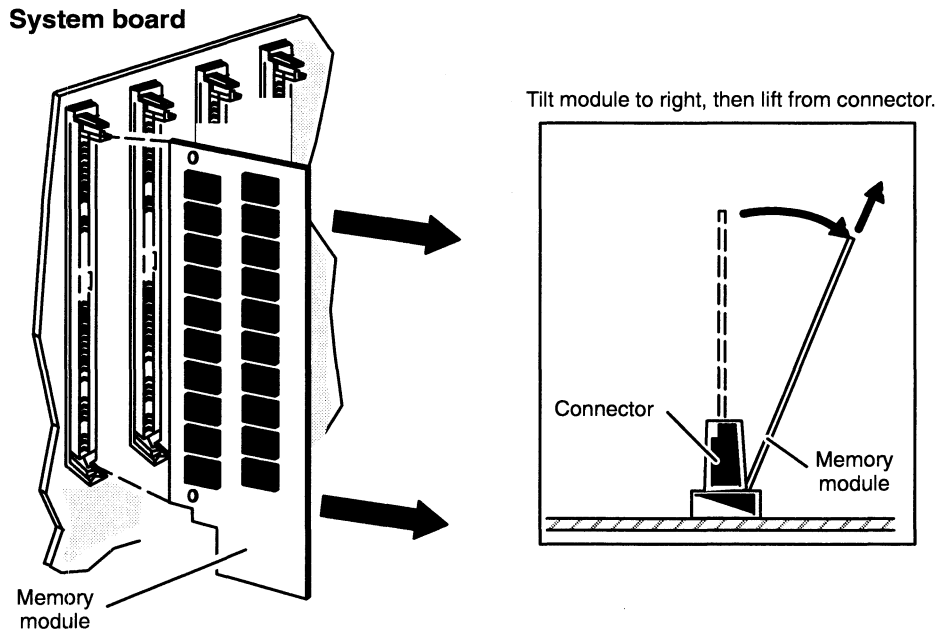

Figure 8-5 Removing a Memory Module

If you removed a failed memory module, insert it in an antistatic bag and return it to Data General. Contact the Customer Support Center, as described in the Preface, for information on returning the faulty part. If you temporarily removed a memory module, insert it in an antistatic bag until you are ready to reinstall it. If you removed all memory modules to replace another system component, return now to the chapter in this manual that instructed you to remove the memory modules. Otherwise, continue to the next section, “Installing Memory Modules,” to install a new memory module.

Installing Memory Modules

Before you can install any memory modules, you must remove the computer unit’s right side cover and attach the ESD wrist strap as described in Chapter 6, “Expanding and Maintaining Your Computer.”

When installing memory modules you must begin by installing the leftmost memory module first (the module that will occupy the lowest numbered connector). Figure 8-3 in this chapter shows the numbering scheme for the memory module connectors. If any memory modules are installed to the right of the memory modules you are installing, you must remove them temporarily if you have not done so already.

To install a memory module, use the following steps.

1. Carefully remove the memory module from its package. Save the antistatic shipping bag and packing materials in case you need to return the module.

CAUTION: *If you need to set the memory module down, put it back inside the antistatic shipping bag.*

2. Position the memory module in the connector at approximately a 20° – 30° angle as shown in Figure 8-6, and then *gently* push the top of the module left towards the perpendicular. You will hear a click as each connector tab locks the module into place.

CAUTION: *Never force the memory module into the connector or against the locking tabs.*

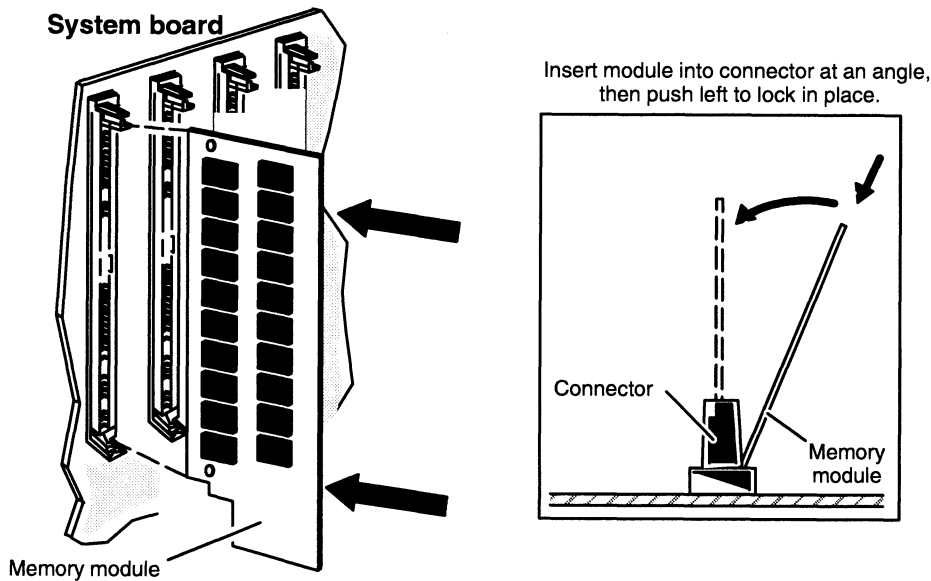

Figure 8-6 Installing the Memory Module in the Connector

Repeat steps 1 and 2 to install or reinstall any remaining memory module(s).

3. If you are not replacing any other CRUs, reinstall the top and side covers as described in the section, “Closing the Computer Unit” in Chapter 6.

NOTE: Your system sizes the amount of memory at each powerup. If you have increased or reduced system memory, your system will interrupt its next powerup and ask you to confirm your memory configuration before continuing.

End of Chapter

Chapter 9

Adding or Replacing a CPU Complex and System Board Options

This chapter contains instructions for adding or replacing *daughter* printed-circuit boards that attach directly to the AViiON 530 or 4600 series system board. All systems contain at least one central processing unit (CPU) complex board. Depending on configuration restraints described in Chapter 6, your system can also include a second CPU complex, an Input/Output (I/O) expansion board, and an 8-bit or 24-bit graphics controller board. Systems with a graphics controller can also add a Z-buffer board for enhanced graphics capabilities.

Figure 9-1 shows the locations of the AViiON 530 and 4600 series system daughter boards.

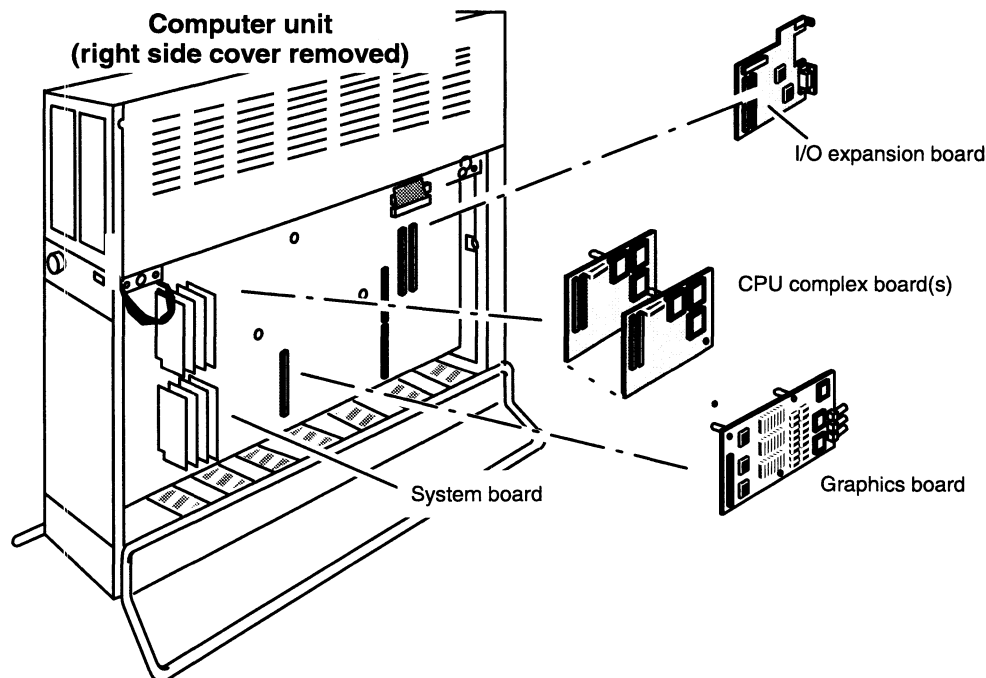

Figure 9-1 AViiON 530 and 4600 Series System Board Options and CPU Complex

Adding or Replacing a CPU Complex Board

This section tells how to add a second CPU complex board to an AViiON 530 or 4600 series computer unit and how to replace a failed CPU complex. You will also need to remove your CPU complex board(s) if you need to replace a failed system board.

A CPU complex board contains one Motorola 88100 central processing unit and two Motorola 88200 Cache Memory Management Units (CMMUs). Your system's first complex board attaches to two interboard connectors on the system board. An optional second CPU complex connects to the first complex via the same 96-pin connectors. Figure 9-2 shows the CPU complex board used in AViiON 530 and 4600 series systems.

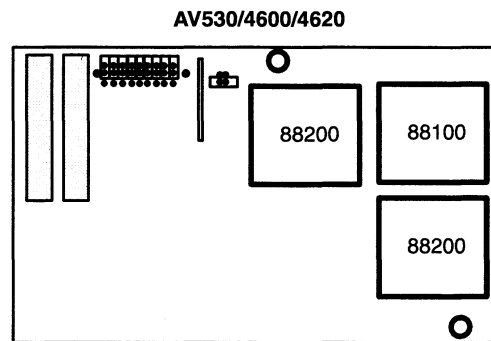

Figure 9-2 AViiON 530 and 4600 Series CPU Complex

A CPU complex board contains one Motorola 88100 central processing unit and two or six Motorola 88200 Cache Memory Management Units (CMMUs). Your system's first complex board attaches to two interboard connectors on the system board. An optional second CPU complex connects to the first complex via the same 96-pin connectors. Figure 9-3 shows the CPU complex boards used in AViiON 530 and 4600 series systems.

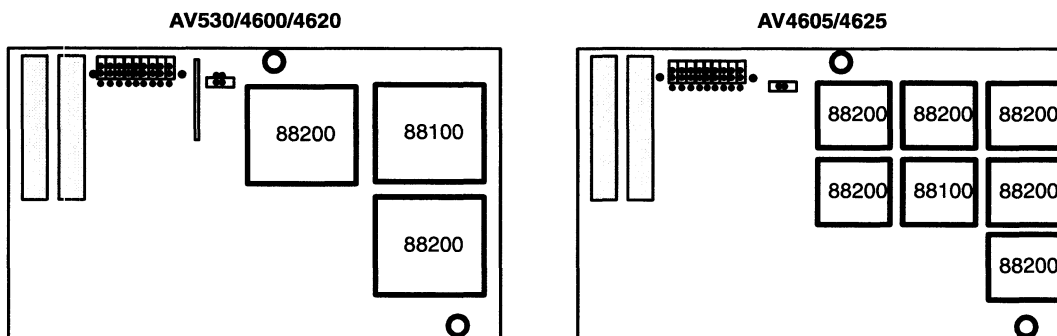

Figure 9-3 AViiON 530 and 4600 Series CPU Complexes

NOTE: Two CPU complex boards within a single computer unit must both contain either two CMMUs or six; AV530 and 4600 series systems *do not* support combinations of 2- and 6-CMMU CPU complex boards.

If you are replacing a failed CPU complex or system board, continue with the next section. If you are adding or reinstalling a CPU complex, skip the next section and continue with the section, “Installing a CPU Complex Board.”

Removing a CPU Complex Board

You will need to remove CPU complex boards to replace them or to replace a failed system board. Before you can remove a CPU complex board, you must prepare your worksite, remove the computer unit’s right side cover, and attach the ESD wrist strap as described in Chapter 6, “Expanding and Maintaining Your Computer System.”

CAUTION: *Unless you are properly grounded, you can discharge static electricity and damage components in the system.*

To remove the CPU complex board, use the following steps. You will need a medium Phillips screwdriver.

1. Remove the two screws, shown in Figure 9-4, that secure the CPU board(s) to the system board.

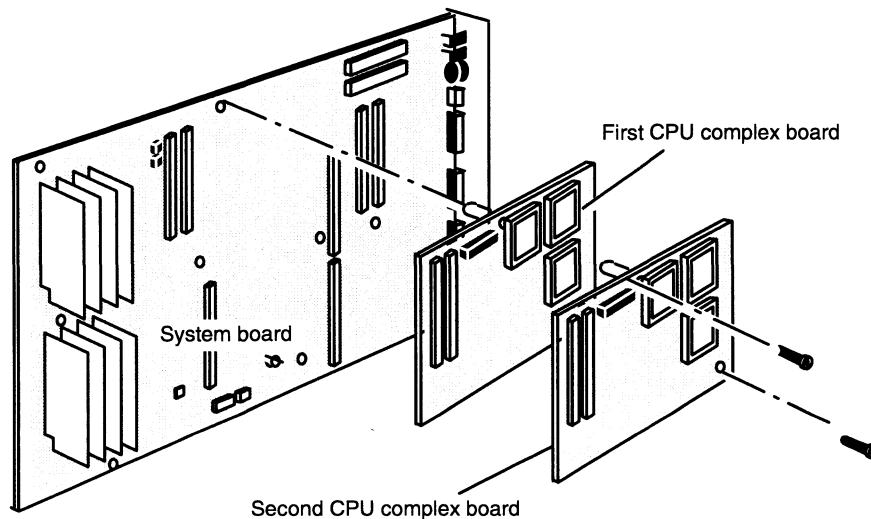

Figure 9-4 Removing the CPU Complex Board Screws

2. Carefully separate the interboard connector on the back of the CPU complex board from the interboard connector on the board beneath it as shown in Figure 9-5.

CAUTION: *Grasp the board at its edges to avoid damaging any components on the board.*

CAUTION: *Grasp the board at its edges to avoid damaging any components on the board. Take particular care when handling the AV4605/4625 CPU complex; do not apply pressure to the clear plastic that covers the 88100/88200 components.*

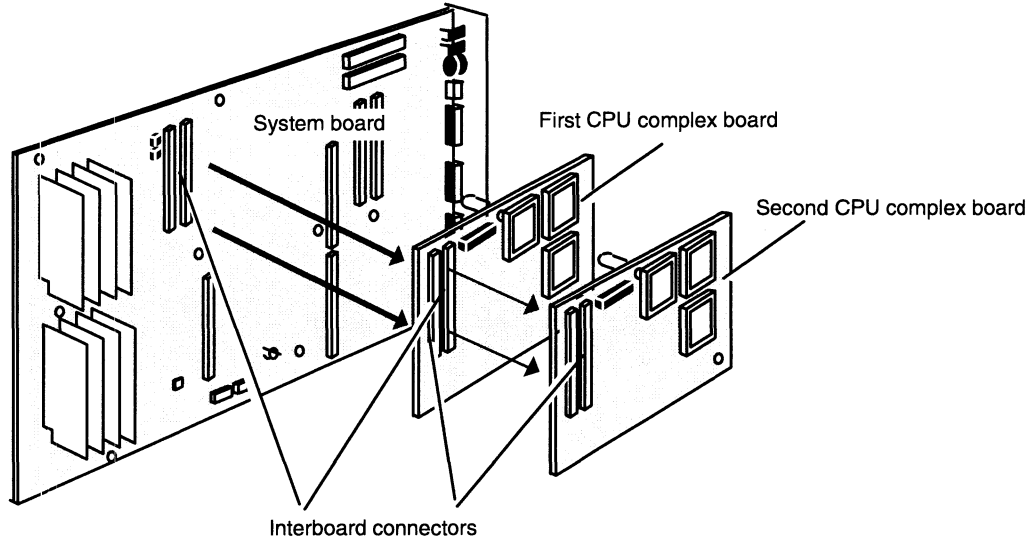

Figure 9-5 Separating the Interboard Connectors

3. Pull the CPU complex board away from the board beneath it, and place it in an antistatic bag.

If you are replacing the CPU complex board, insert it in an antistatic bag and return it to Data General. Contact the Customer Support Center, as described in the Preface, for information on returning the faulty part.

If you removed the CPU complex board temporarily to replace the system board, put the board inside an antistatic bag until you are ready to reinstall it, and go to Chapter 10, "Replacing the System Board." Otherwise, continue to the next section, "Specifying CPU Configurations," before installing the new CPU complex board.

Specifying CPU Configurations

Your system uses jumpers on the system board and CPU complex board(s) to specify the number of central processing units and cache memory management units in the system. Before you install a new CPU complex board, you must make certain that these jumpers correctly reflect the number and type of CPU complex boards in your system.

Follow the steps below to examine and reinstall the CPU configuration jumpers on your system board and CPU designator jumpers on your CPU complex board(s). If you are replacing a CPU complex board, you can skip step 1 and continue with step 2.

1. Verify, and if necessary reset, the CPU configuration jumpers on your system board as indicated in Figure 9-6.

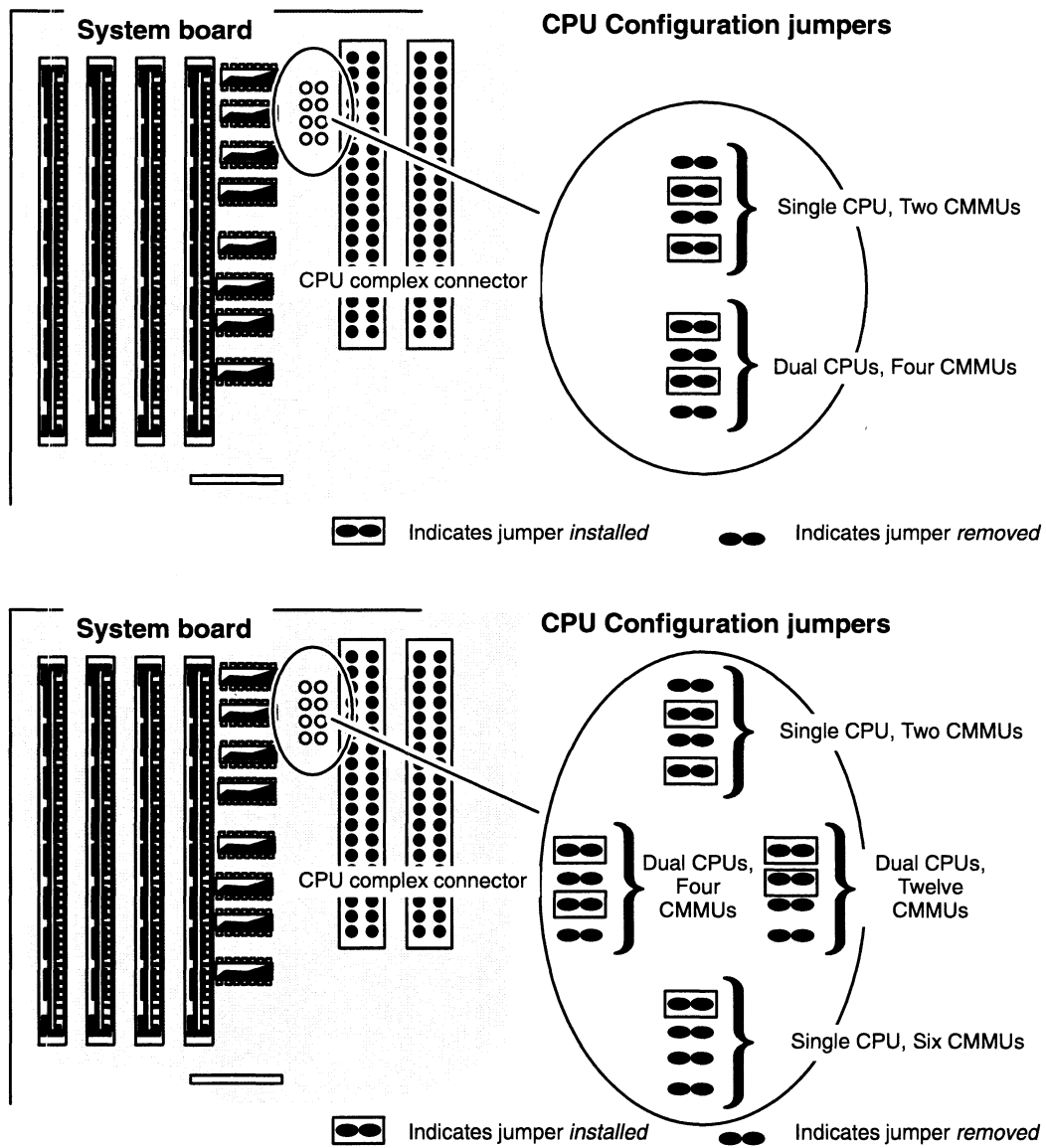

Figure 9-6 CPU Configuration Jumpers on the System Board

NOTE: Incorrectly configured system and CPU complex boards will cause your system to fail powerup.

Two CPU complex boards within a single computer unit must both contain either two CMMUs or six; AV530 and 4600 series systems *do not support* combinations of 2- and 6-CMMU CPU complex boards.

- Carefully remove the new CPU complex board from its package. Save the antistatic shipping bag and packing materials to use if you have to return the option board.

CAUTION: *If you need to set the board down, put it back inside the antistatic shipping bag.*

- Verify, and if necessary reset, the jumpers in the new CPU complex board as indicated in Figure 9-7. Note that the “first” complex must attach to the system board; a complex jumpered as the “second” board attaches to the first.

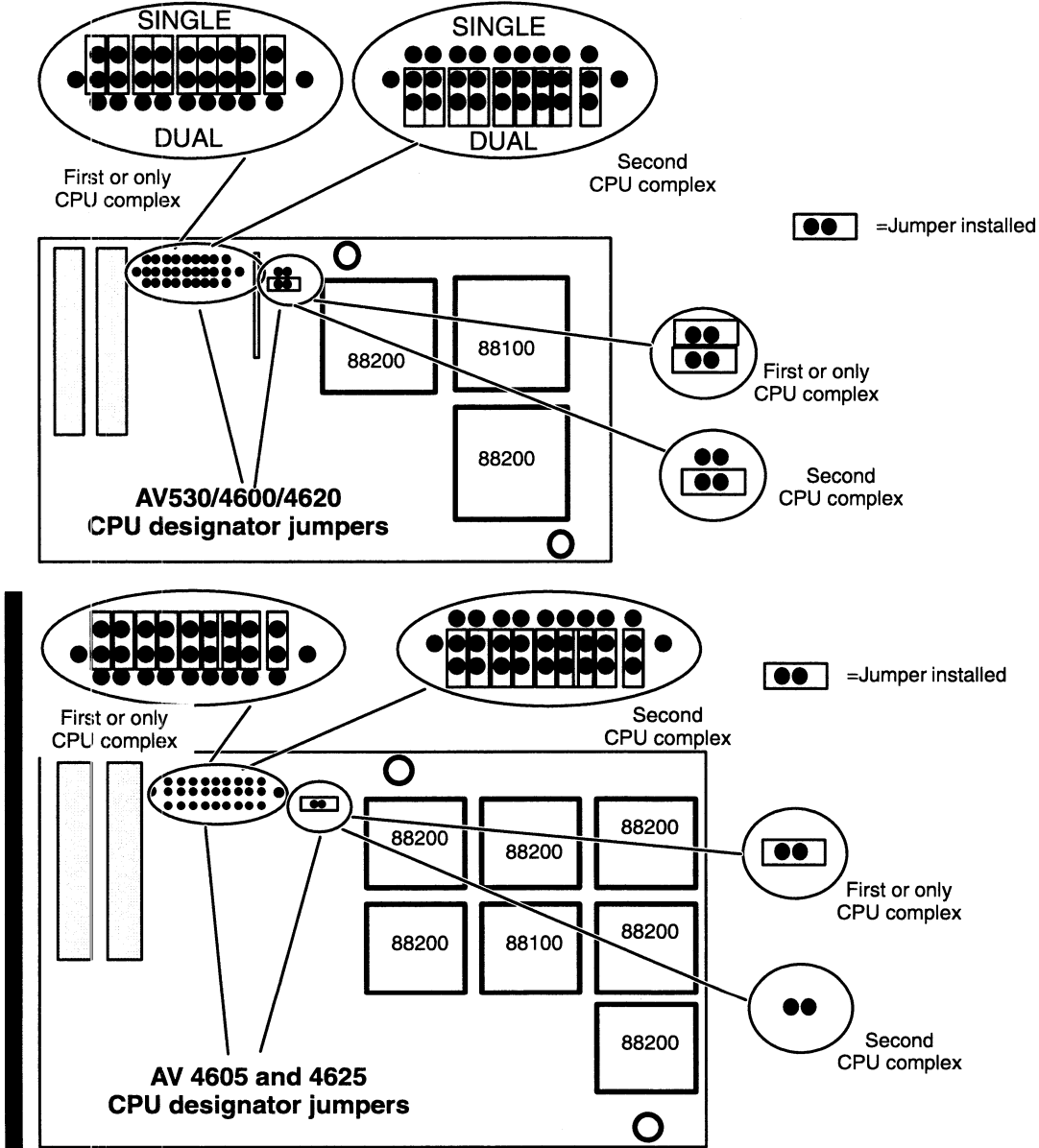

Figure 9-7 AViiON 530 and 4600 Series CPU Complex Configuration

Installing a CPU Complex Board

Before you can install a CPU complex board, you must remove the computer unit’s right side cover and attach the ESD wrist strap as described in the “Opening the Computer Unit” section of Chapter 1.

CAUTION: *Unless you are properly grounded, you can discharge static electricity and damage components in the system.*

To install a CPU complex board, follow the steps below.

1. Align the interboard connector on the CPU complex board with the interboard connector on the board beneath it, as shown in Figure 9-8, and press them together. If you cannot press the connectors together, make sure that the connectors are aligned correctly, and then try pressing them together again.

CAUTION: Grasp the board at its edges to avoid damaging any components on the board.

CAUTION: Grasp the board at its edges to avoid damaging any components on the board. Take particular care when handling the AV4605/4625 CPU complex; do not apply pressure to the clear plastic that covers the 88100/88200 components.

NOTE: When you install two CPU complex boards, attach the first complex to the system board before attaching the second CPU complex to the first.

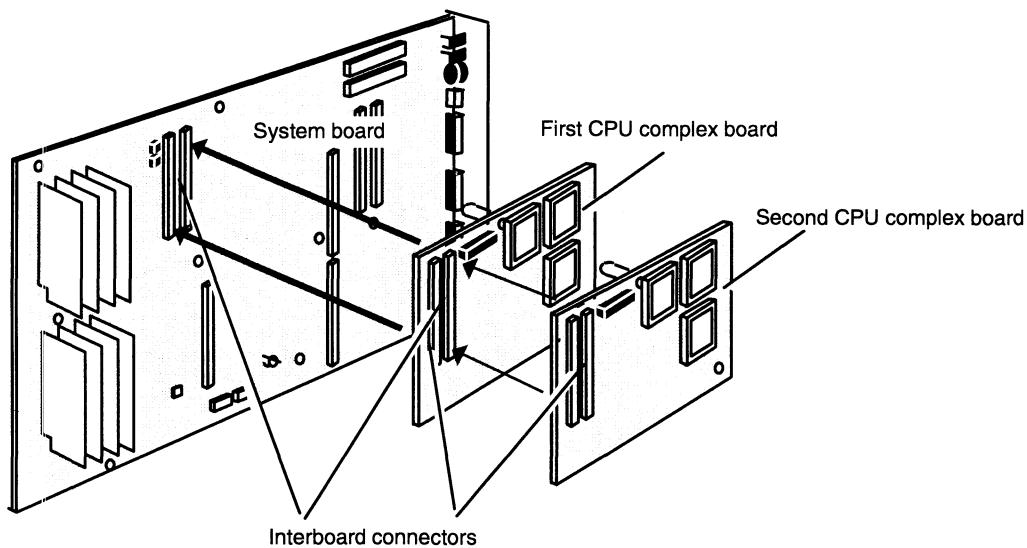

Figure 9-8 Joining the Interboard Connectors

2. Secure the CPU complex board(s) to the system board with the two screws as shown in Figure 9-9.

NOTE: A second CPU complex board requires longer board-retaining screws. If you are adding or replacing a second CPU complex, discard two of the three shorter board-retaining screws and replace them with the two longer board-retaining screws shipped with the CPU complex board.

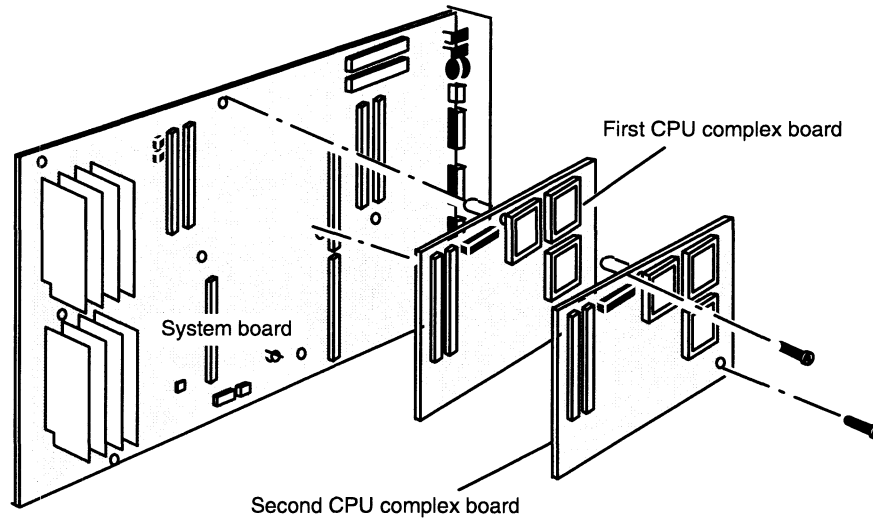

Figure 9-9 Securing CPU Complex Boards to the System Board

3. Reinstall the side cover as described in Chapter 6, “Expanding and Maintaining Your Computer System.”

Adding or Replacing an I/O Expansion Board

Your base system includes a Small Computer System Interface (SCSI) controller and an Ethernet LAN controller integrated onto the system board. This section describes how to add or replace an Input/Output (I/O) expansion board that contains a second integrated SCSI and a second integrated LAN controller.

An I/O expansion board plugs into two interboard connectors on the system board, and includes brackets that secure the expansion board to the computer unit rear panel. Figure 9-10 shows the I/O expansion board and connector locations.

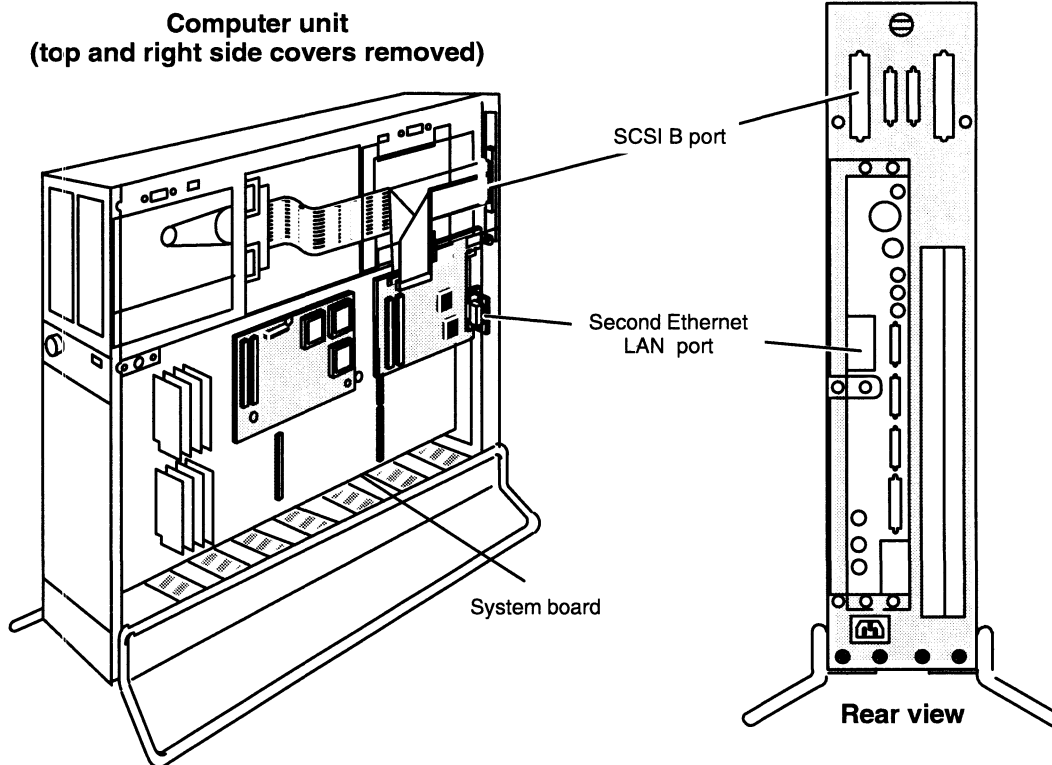

Figure 9-10 I/O Expansion Board Location and Connectors

Removing an I/O Expansion Board

If your system includes an I/O expansion board, you will need to remove the board to replace it or to replace a failed system board. Before you can remove the board, you must prepare a worksite, remove the computer unit's right side, and attach the ESD wrist strap as described in Chapter 6, "Expanding and Maintaining Your Computer System."

CAUTION: *Unless you are properly grounded, you can discharge static electricity and damage components in the system.*

To remove an I/O expansion board, follow the steps listed next. You will need a medium Phillips screwdriver.

1. Disconnect any external cables attached to the SCSI B and second LAN connectors on your computer unit bulkhead.
2. Disconnect the ribbon cable connecting the I/O expansion board to the SCSI B connector as shown in Figure 9-11.

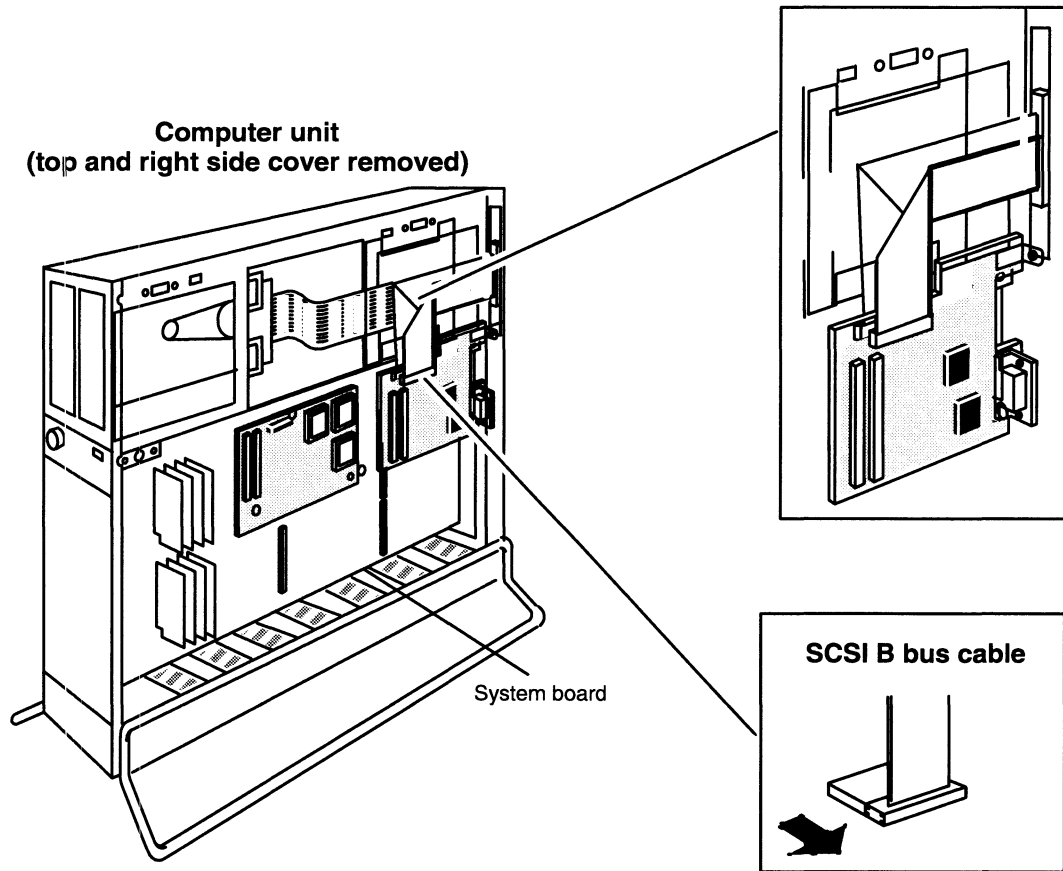

Figure 9-11 I/O Expansion Board SCSI Ribbon Cable

3. Remove the two screws that secure your I/O expansion board to the computer unit bulkhead, as shown in Figure 9-12.

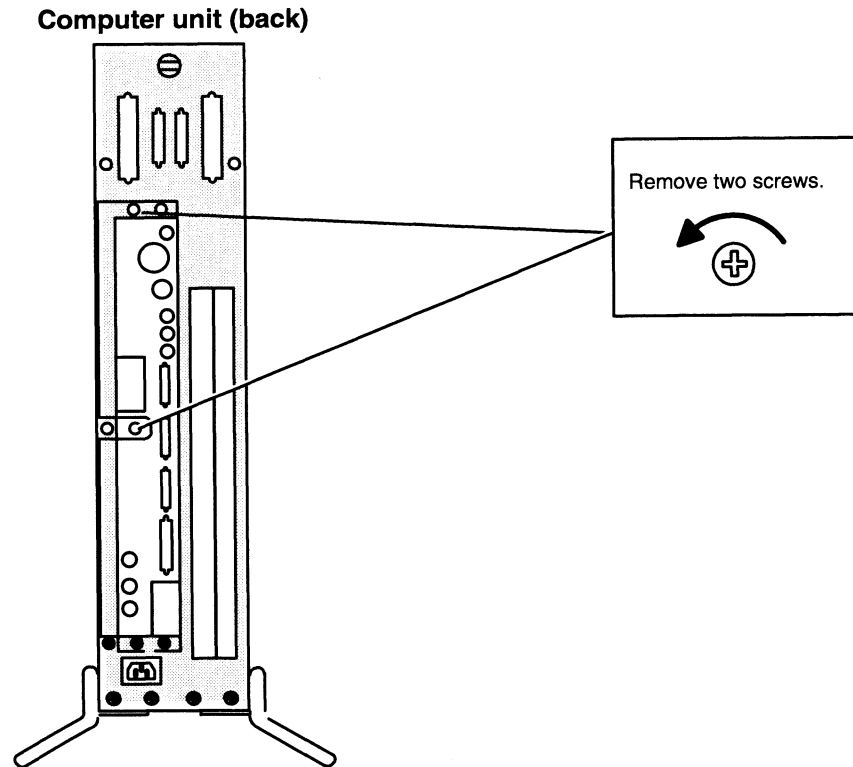

Figure 9-12 Releasing the I/O Expansion Board from the Computer Bulkhead

4. Separate the interboard connectors on the back of the board from the connectors on the system board as shown in Figure 9-13.

CAUTION: Grasp the board at its edges to avoid damaging any components on the board.

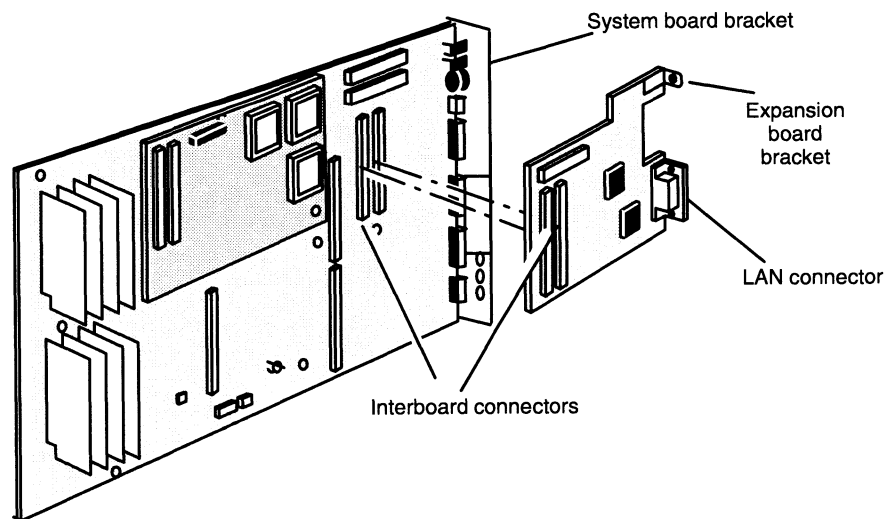

Figure 9-13 Separating the Interboard Connectors

5. Lift the board away from the system board, and place it in an antistatic bag.

If you removed a failed board, insert it in an antistatic bag and return it to Data General. Contact the Customer Support Center, as described in the Preface, for information on returning the faulty part.

If you temporarily removed a board, put it inside an antistatic bag until you are ready to reinstall it.

6. If you removed the I/O board to replace it with a new board, proceed to the next section, "Installing an I/O Expansion Board."

If you are removing all daughter boards to replace the system board, remove the next board by following the steps in the appropriate section of this chapter. If you have removed all CPU and option boards, proceed to the next chapter, "Replacing the System Board."

Installing an I/O Expansion Board

Before you can install an I/O expansion board, you must prepare your worksite, remove the computer unit's right side, and attach the ESD wrist strap as described in Chapter 6, "Expanding and Maintaining Your Computer System." To install a new I/O board in a system that previously had none, you will also need to remove the top cover.

CAUTION: Unless you are properly grounded, you can discharge static electricity and damage components in the system.

To install an I/O expansion board, follow the steps below. You will need a medium Phillips screwdriver.

To install a new I/O expansion board in a system that previously had none, start with Step 1. To install a replacement board in your system, start with Step 2. To reinstall a board you removed temporarily, start with Step 3.

1. Remove the filler plates that cover the SCSI B and second Ethernet connector openings on the computer unit bulkhead. Figure 9-14 shows the filler plate locations.

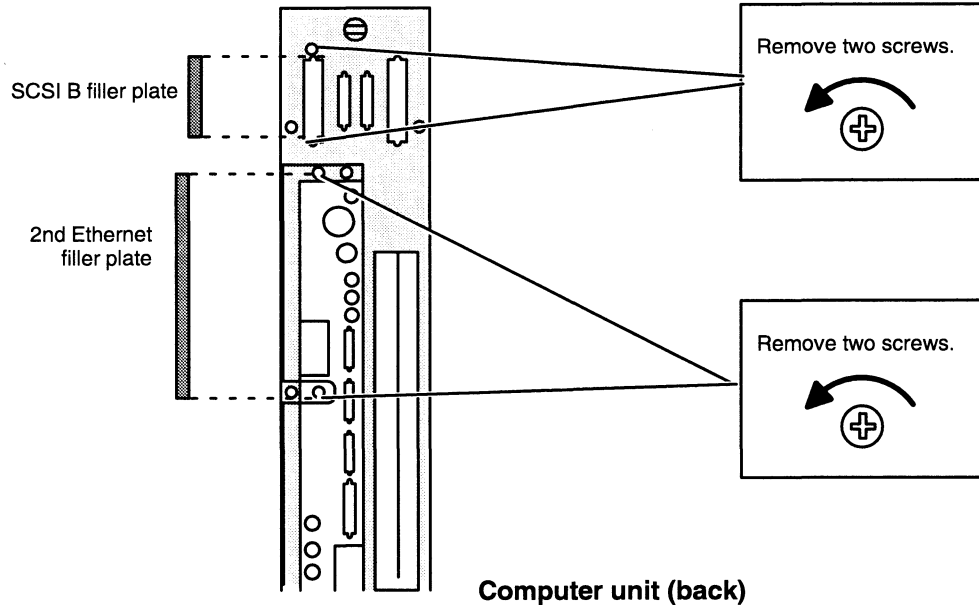

Figure 9-14 Removing SCSI B and Second Ethernet Connector Filler Plates

2. Carefully remove the option board from its package. Save the antistatic shipping bag and packing materials to use if you have to return the option board.

CAUTION: If you need to set the option board down, put it back inside the antistatic shipping bag.

3. Position the Ethernet LAN connector in the openings provided by the system board bracket and the computer unit bulkhead, then align the interboard connectors and press them together as shown in Figure 9-15. If you cannot press the connectors together, make sure that the connectors are aligned correctly, and then try pressing them together again.

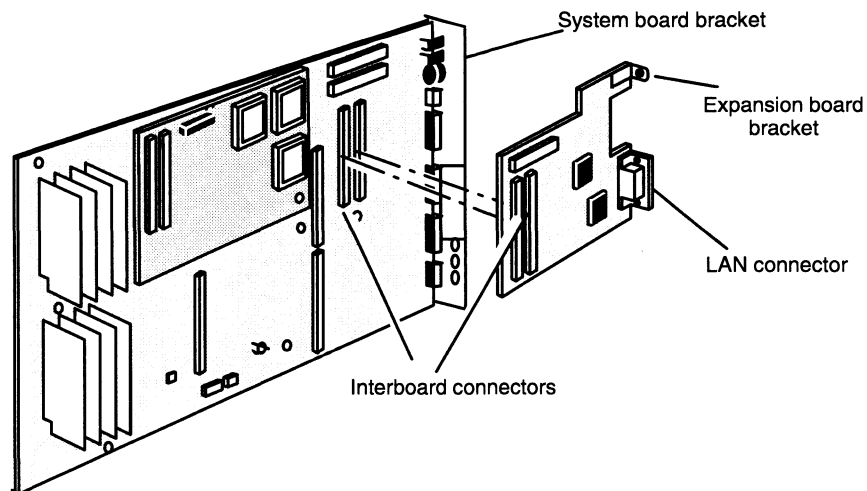

Figure 9-15 Joining the Interboard Connectors

NOTE: Since the bulkhead and system board openings are larger than the standard 15-pin LAN connector, the connector assembly includes a small filler plate to cover the bulkhead opening from the inside.

4. Align the expansion board brackets with the holes in the system board bracket and computer unit bulkhead, and insert the two screws as shown in Figure 9-16.

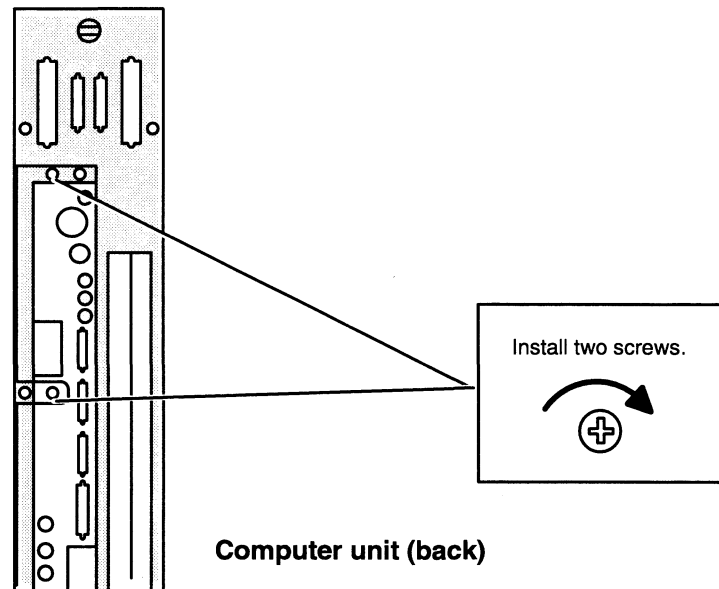

Figure 9-16 Securing the I/O Expansion Board to the Computer Unit Bulkhead

To install a replacement I/O expansion board, or to reinstall one removed for access to the system board, skip Step 5 through Step 7 and continue with Step 8. To install a new I/O board in a system that previously had none, continue with Step 5.

5. Secure the SCSI cable's 50-pin CHAMP connector to the computer unit bulkhead as shown in Figure 9-17.

NOTE: To create more room within the chassis for connecting the SCSI B connector to the bulkhead, you may need to move any full-height disk in the rear device bay. Simply remove the 8 screws that secure the rear drive assembly to the chassis, then slide the assembly forward. (Refer to the illustrations in Chapter 7, if necessary.)

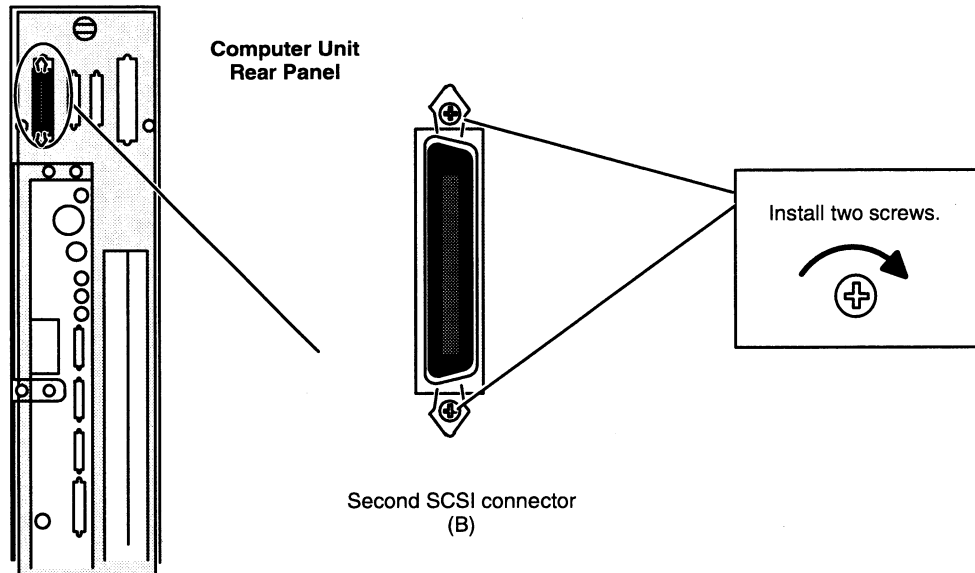

Figure 9-17 Installing the SCSI B Connector

6. Remove the clear plastic cable clamp as shown in Figure 9-18.
7. Press the SCSI B ribbon cable against the COM port and SCSI A ribbon cables *without altering the cable fold*, and replace the cable clamp over all three cables. Figure 9-18 shows how to properly install the SCSI B ribbon cable.
8. Attach the ribbon cable from the SCSI B connector to the SCSI connector on the I/O expansion board as shown in Figure 9-18. Since the connector is keyed, you can only attach it one way.

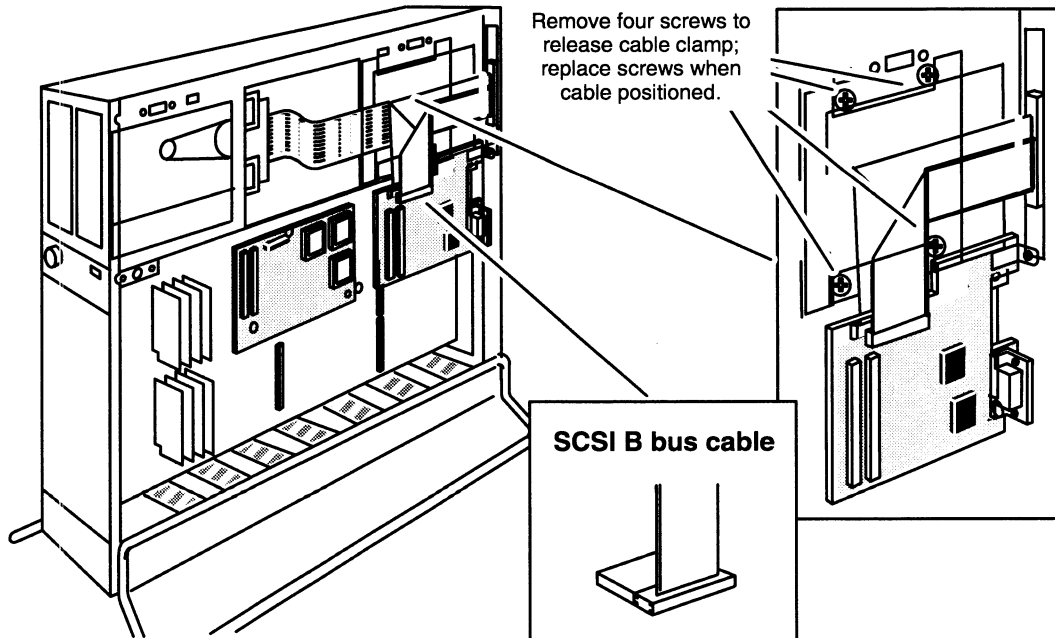

Figure 9-18 Attaching the SCSI B Ribbon Cable to the I/O Expansion Board

9. Reinstall the top and side covers as described in Chapter 6, “Expanding and Maintaining Your Computer System.”

To connect an Ethernet LAN or an existing SCSI B bus to the I/O expansion board controllers, refer to Chapter 2, “Setting Up your Computer System.” To set up a new SCSI bus, refer to Chapter 4, “Setting Up and Installing a SCSI Bus.”

To test a new or replacement board, you should run a diagnostics acceptance test after your next powerup. Refer to *Using AViiON System Diagnostics* for instructions on running the acceptance test and other diagnostic utilities.

Adding or Replacing a Graphics or Z-Buffer Board (530 series)

This section explains how to add a graphics or z-buffer board to your computer unit and to replace a failed graphics board or z-buffer board in an AViiON 530 series computer unit. If your computer system has a graphics board or z-buffer board, you will need to remove them to replace a failed system board.

A graphics board plugs into an interboard connector on the system board. The z-buffer board plugs into an interboard connector on the graphics board. Figure 9-19 shows the location of graphics and z-buffer boards on the system board.

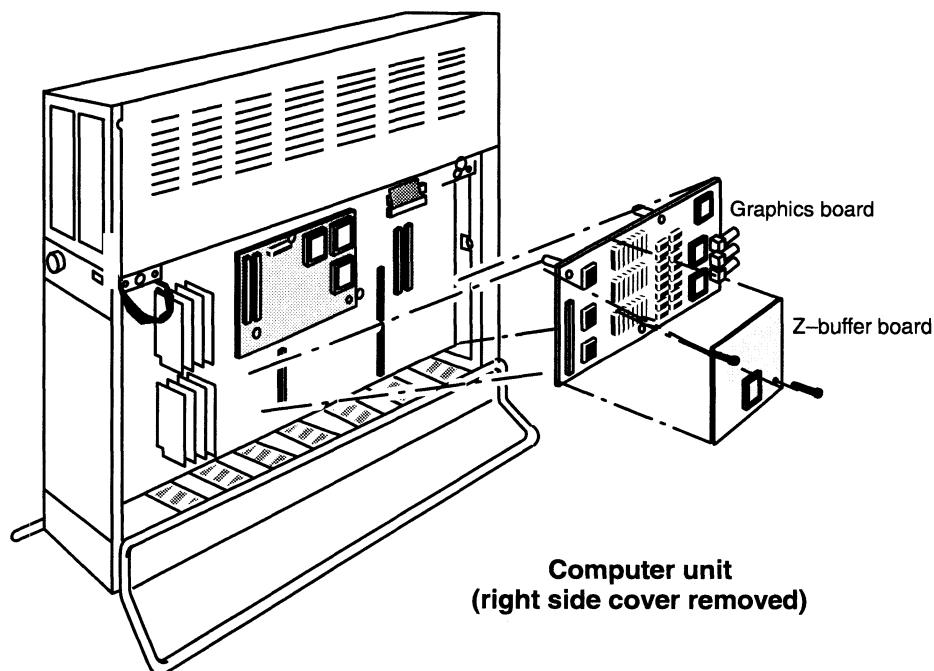

Figure 9-19 Location of the Graphics and Z-Buffer Boards on the AViiON 530 Series System Board

Removing the Graphics or Z-Buffer Board

You will need to remove a graphics board or z-buffer board to replace them or a failing system board. Before you can remove the graphics board or z-buffer board, you must remove the computer unit's right side cover and attach the ESD wrist strap as described in the "Opening the Computer Unit" section of Chapter 1.

CAUTION: *Unless you are properly grounded, you can discharge static electricity and damage components in the system.*

To remove the graphics or z-buffer boards, follow the steps below. You will need a medium Phillips screwdriver. If you are installing a graphics controller board, you might also need a flat-blade screwdriver and a medium-sized adjustable wrench.

1. If you are removing a graphics controller board, remove the hexagonal retaining nuts and the washers that secure the monitor connectors to the computer unit bulkhead, as shown in Figure 9-20. If you cannot release the nuts with your fingers, use an adjustable wrench.

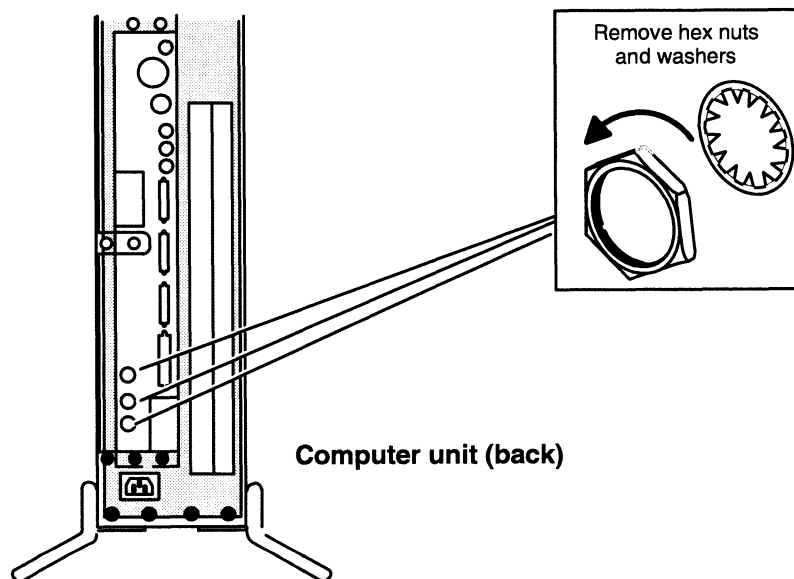

Figure 9-20 Releasing the Graphics Monitor Connectors from the Computer Bulkhead

2. Remove the board-retaining screws from the board you are removing. Figure 9-21 shows the location of the board-retaining screws on the option boards.

