

THIS DRAWING AND SPECIFICATIONS HEREIN ARE THE PROPERTY OF DATA GENERAL CORPORATION AND SHALL NOT BE REPRODUCED OR COPIED OR USED IN WHOLE OR IN PART AS THE BASIS FOR MANUFACTURE OR SALE OF ITEMS WITHOUT WRITTEN PERMISSION.

REVISIONS				
REV	DESCRIPTION	DRAFTG	APP BY	DATE
00	RELEASED PER ECO-3852			11/4/75

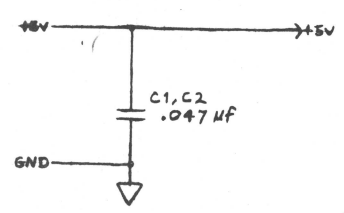
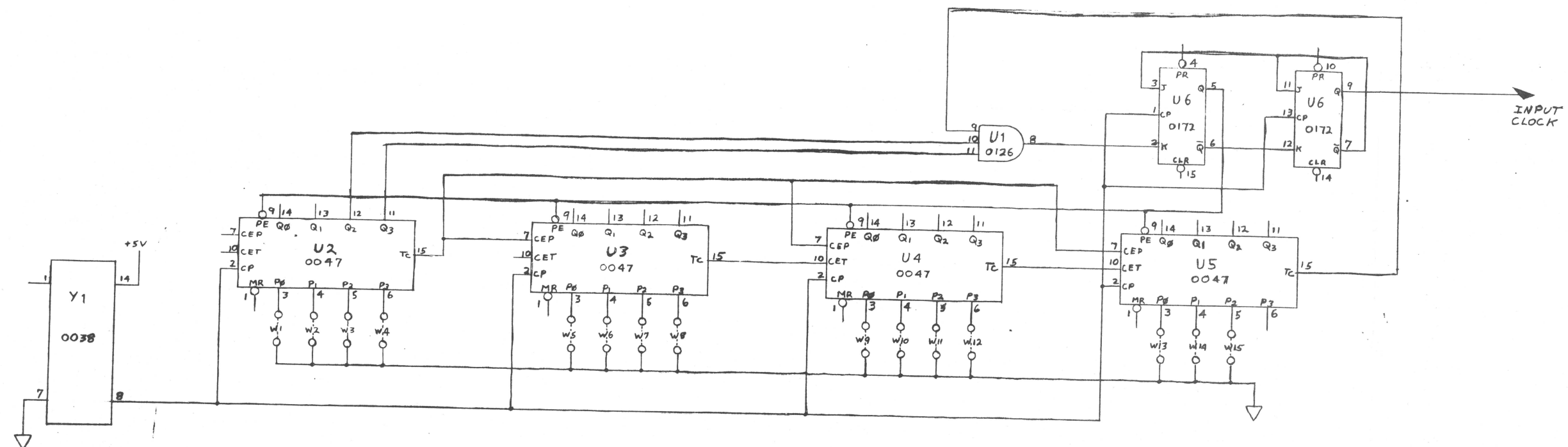

BAUD RATE	INSTALL JUMPERS
75	W8, W10, W13, W15
110	W7, W12, W13, W14
134.5	W5, W6, W7, W8, W9, W11, W12, W14
150	W7, W9, W12, W14
300	W6, W8, W11, W13
600	W5, W7, W10, W12
1200	W4, W6, W9, W11
1800	W5, W6, W7, W9, W10
2400	W3, W5, W8, W10
4800	W2, W4, W7, W9
7200	W3, W4, W5, W7, W8
9600	W1, W3, W6, W8

DRAWING 40-558 20411

ARTWORK: 107000573		UNLESS OTHERWISE SPECIFIED USE D.G.C. SPECIFICATION 108-00028 FOR TOLERANCES AND WORKMANSHIP REQUIREMENTS	QTY	DESCRIPTION	PART NO
ARTWORK VS SCHEMATIC			DRAWN	20 SEPT 75	DATA GENERAL CORPORATION SOUTHBORO, MASSACHUSETTS 01772
REV	SCHEMATIC REV(S)	CHECKED	10-29 75	TITLE	
01	00	ENGINEER	20 SEPT 75	BASIC I/O BOARD	
		APPROVED	10/21	JUMPER SELECTABLE TTY CLOCK	
		MATERIAL			
		FINISH			
		FIRST USED ON	4010		
		SCALE			
		SIZE	D	CODE	
		DRAWING NUMBER	001 000090	REV	
				00	