

Field Engineers
Maintenance Series

**DASHER™
LP2 AND TP2
PRINTERS**

015-000098-00

1



**Field Engineers
Maintenance Series**

**DASHER™
LP2 AND TP2
PRINTERS**

015-000098-00

NOTICE

Data General Corporation (DGC) has prepared this manual for use by DGC personnel and customers as a guide to the proper installation, operation, and maintenance of DGC equipment and software. The drawings and specifications contained herein are the property of DGC and shall neither be reproduced in whole or in part without DGC prior written approval nor be implied to grant any license to make, use, or sell equipment manufactured in accordance herewith.

DGC reserves the right to make changes without notice in the specifications and materials contained herein and shall not be responsible for any damages (including consequential) caused by reliance on the materials presented, including but not limited to typographical or arithmetic errors, company policy and pricing information. The information contained herein on DGC software is summary in nature. More detailed information on DGC software is available in current released publications.

NOVA, **INFOS** and **ECLIPSE** are registered trademarks of Data General Corporation, Westboro, Massachusetts. **DASHER** and **microNOVA** are trademarks of Data General Corporation, Westboro, Massachusetts.

Ordering No. 015-000098
© Data General Corporation, 1979, 1980
All Rights Reserved
Printed in the United States of America
Rev. 00, June 1980

**DASHER
LP2 AND TP2
PRINTERS**

INTRODUCTION TO DASHER LP2 AND TP2 PRINTERS

1

INSTALLATION AND TROUBLESHOOTING

2

FUNCTIONAL OVERVIEW

3

MAINTENANCE

4

PREFACE

This manual tells you how to install, maintain, and troubleshoot a DASHER LP2 or TP2 printer. It is written specifically with the Level 1 Field Service Engineer in mind. All troubleshooting procedures isolate problems to an assembly or subassembly level, commonly called 'board swapping'.

The manual is organized around four parts:

- *Part I is an introduction to DASHER LP2 and TP2 printers.*
- *Part II covers installation and troubleshooting problems using 'cookbook' procedures, flowcharts, and tables showing symptom, probable cause, and corrective action.*
- *Part III explains the theory behind a printer's operation and explains the interactions of the various assemblies.*
- *Part IV contains detailed replacement and adjustment procedures.*

The appendices contain commonly used reference information.

We assume you have access to and know how to use a voltmeter, a DASHER Terminal Tester, and a Philips 0 - Scope. In addition, you should know how to load a test program from magnetic tape or field service cassette. Customers should note that certain test equipment and/or repair equipment is available to DGC field service engineers only.

Warning - *The power supplies in these units have hazardous voltages on their printed circuit boards. They should be repaired only by trained service personnel.*

CONTENTS

Part 1	Introduction to Dasher LP2 and TP2 Printers
1-3	Chapter 1 OVERVIEW
1-15	Chapter 2 OPERATOR CONTROLS
Part 2	Installation & Troubleshooting
2-3	Chapter 3 HOW TO USE PART 2
2-5	Chapter 4 INSTALLATION
2-9	Chapter 5 FAULT DETECTORS
2-11	Chapter 6 POWER-UP AND FAULT TROUBLESHOOTING
2-21	Chapter 7 SELF-TEST FEATURE
2-25	Chapter 8 RELIABILITY PROGRAM
2-29	Chapter 9 TERMINAL TESTER
2-33	Chapter 10 TEST PROBLEMS

Part 3 Functional Overview

**3-3 Chapter 11
ARCHITECTURE**

**3-9 Chapter 12
FIELD REPLACEMENT UNIT INTERACTION**

Part 4 Maintenance

**4-3 Chapter 13
GENERAL INFORMATION**

**4-5 Chapter 14
PREVENTIVE MAINTENANCE PROCEDURES**

**4-7 Chapter 15
REPLACEMENT PROCEDURES**

**4-29 Chapter 16
ADJUSTMENT PROCEDURES**

**4-51 Appendix A
ASCII-128 CHARACTER CODES**

**4-55 Appendix B
SUMMARY OF CONTROL AND ESCAPE SEQUENCES**

**4-59 Appendix C
JUMPERING**

**4-63 Appendix D
EXTERNAL CABLES**

**4-69 Appendix E
INTERNAL CABLING AND INTERCONNECTION DIAGRAM**

**4-73 Appendix F
FIELD REPLACEMENT UNIT PART NUMBERS**

Part 1

Introduction to DasherTM LP2 and TP2 Printers

1



Chapter 1

OVERVIEW

INTRODUCTION

All DASHER LP2 and TP2 printers are capable of printing at burst speeds of up to 180 characters per second. Actual printing throughput times vary according to the number of characters per line, as shown in Figure 1.1. Printing is bidirectional and incorporates a "logic seeking" algorithm. This algorithm determines the shortest route to a character, reducing the time that would normally be spent performing unnecessary carriage returns.

The printing mechanism contains a nine-wire printhead which forms 7 x 9 dot-matrix characters. A leadscrew assembly moves the printhead, ensuring precise printhead positioning. Moveable, pin-feed tractors accommodate 1 to 6 part forms ranging from 4 to 15 inches in width.

A self test program allows an operator to verify that a printer is operating correctly without the aid of additional diagnostic tools.

1

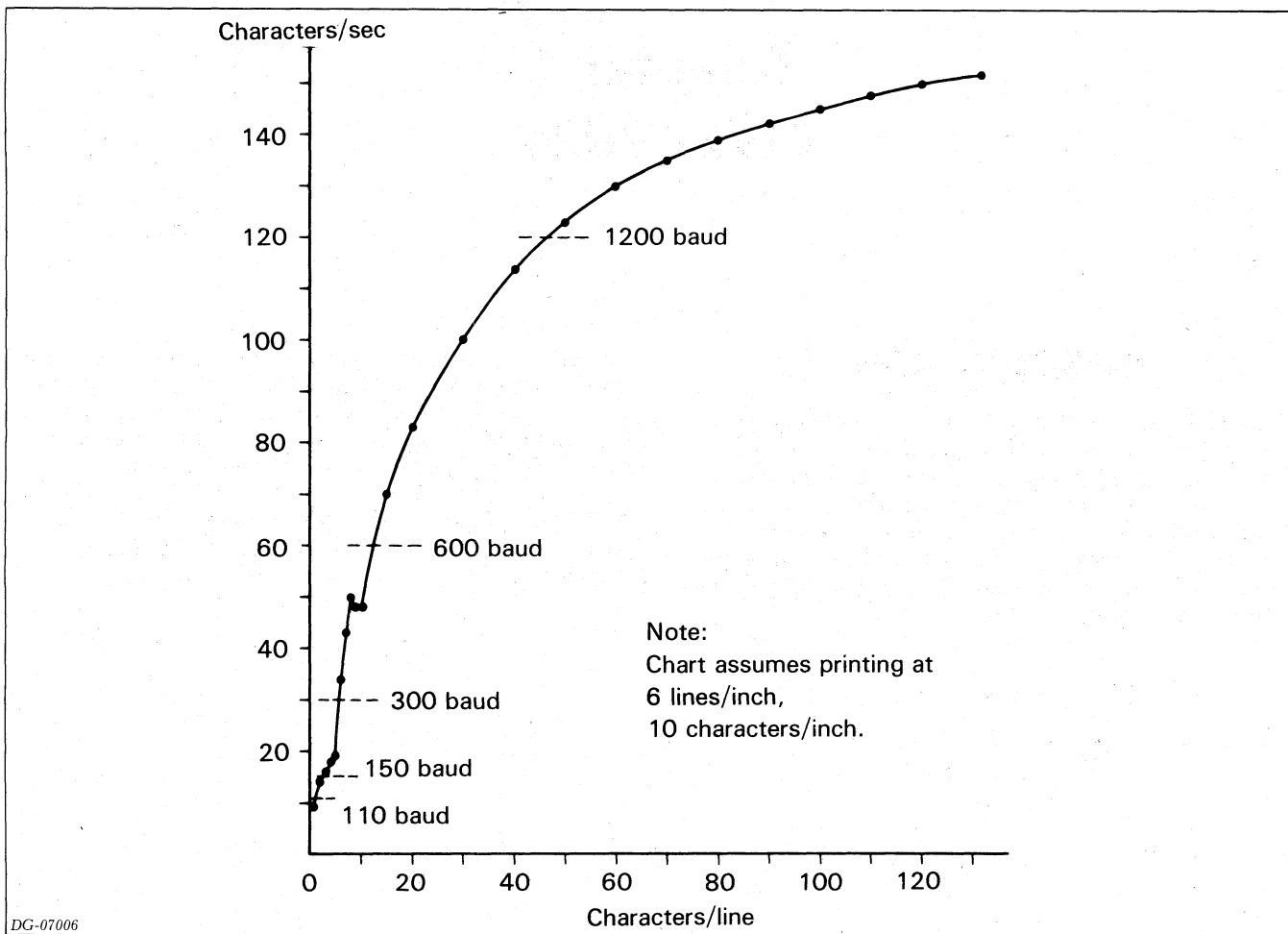

DG-07006

Figure 1.1 DASHER LP2/TP2 Throughput Chart

DASHER LP2 and TP2 printers include the following features:

- Horizontal and vertical tabbing
- Plotting
- Underscoring
- Elongated printing
- 6 or 8 lines per inch vertical spacing
- Automatic form feed (option on S models)
- Down line loaded character set
- Compressed printing (option)
- Alternate character set (option)

The switch selectable view mode allows you to see the last line of characters printed by moving the printhead out of the way if there is a pause in printing.

Printers are supplied with one of five international character fonts: American, British, French, German, and Swedish. Units with the alternate character set option contain two of these fonts.

Standard Features (All Models)

Horizontal Tabbing - Allows you to set or clear horizontal tabs anywhere in the 132 character line. You can set any number of tabs, using just one escape sequence.

Vertical Tabbing - Allows you to move to any line in your form. You can set all the vertical tabs for a form, using just one escape sequence (automatic form feed option must be installed).

Plotting - Allows you complete control over 7 of the 9 individual print wires. The 7-bit codes received by your printer directly determine which of these 7 printhead wires will fire to form a particular column. While in plot mode, there is no interline spacing so you can print continuous graphs.

6 or 8 Lines/Inch - Allows you to select the interline spacing you want on a form. The selection is made by a switch located on the Secondary Control Panel.

Elongated Printing - Allows you to print characters at twice the width of normal characters (normal 10 characters/inch; elongated 5 characters/inch). You can switch to elongated printing at any time for as long as you

OVERVIEW

like.

Underscoring - Allows you to underline characters, strings, or complete lines. The underscore is printed at the same time as the character so your printer doesn't waste time scanning a line twice to fill in the underscores.

Down Line Loaded Character Set - Allows your system to load a character set into your printer. You may design your own character set with up to 118 printable characters.

Optional Features

Parallel Interface - Allows you to connect a printer to systems equipped with a parallel ASCII line-printer interface. The parallel interface transfers 8 bits of information at a time. In addition, it sends signals which inform the system when the printer is powered-up and online as well as when the printer's buffer can accept characters.

Serial Interface - Allows you to connect a printer to asynchronous communications equipment. This interface transfers a serial data stream in either direction between your printer and a communications system. The interface has eight different transfer rates from 110 to 4800 baud. In addition, there are a number of jumper selectable data formats.

NOVA/ECLIPSE Programmed I/O Controller - Allows you to connect a printer to a Data General system previously without a line printer interface. The controller communicates with a NOVA or ECLIPSE CPU via programmed I/O instructions. It resides on a 15-inch square circuit board which plugs into any I/O slot of a NOVA or ECLIPSE computer chassis.

NOVA/ECLIPSE Data Channel Controller - Allows you to connect a printer to a Data General system previously without a line printer interface. The controller communicates with a NOVA or ECLIPSE CPU via the data channel. It resides on a 15-inch square circuit board which plugs into any I/O slot of a NOVA or ECLIPSE computer chassis.

Automatic Form Feed - Allows you to advance the paper to the top of the next form in one operation. This option must be installed if you want to use vertical tabbing. Included is the automatic perforation skip-over feature which allows you to skip the perforation between forms.

Compressed Print - Allows you to print 132 characters/line on 8 1/2-inch wide paper instead of 14-inch paper.

	CHARACTERS PER INCH	
	Regular	Elongated
NORMAL	10	5
COMPRESSED	16.5	8.25

Table 1.1

Alternate Character Set - Allows you to print characters from a second and completely independent character set. This second character set may be any one of the five international character fonts. You may switch from one character set to the other on a character by character basis.

Ribbon Cartridges - Replacement fabric-type continuous-feed ribbon cartridges for use on all model printers.

Paper Holder - Collects and stacks fan-fold style forms from a printer.

Model Numbers

DASHER LP2 printers, models 6073 - 6074, are receive-only (RO) devices equipped with a parallel interface. They communicate with a computer via a line printer controller. Models 6086 - 6089 are LP2 printers sold with either of two line printer controllers.

DASHER TP2 printers, models 6075 - 6078, are either receive only devices (RO) or keyboard send receive (KSR) devices equipped with an asynchronous serial interface. TP2 printers communicate with a computer via any of a variety of asynchronous serial controllers. TP2 printers provide both EIA standard RS-232C and 20mA current loop connections.

A printer's model number is stamped on the plate located near the bottom of the pedestal, near the power cord connector.

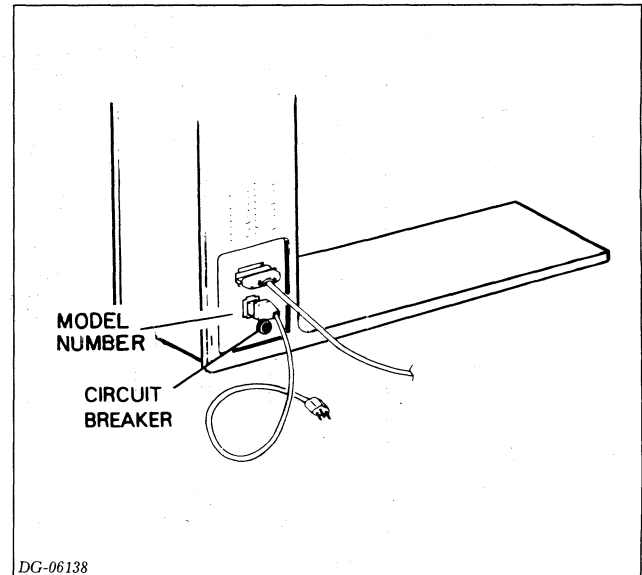

Figure 1.2 Model Number Location

Table 1.2 lists the various model numbers along with their available options.

DASHER LP2 AND TP2 PRINTERS

PRINTERS		ADDITIONAL FEATURES INCLUDED (NOT COMMON TO ALL MODELS)	ADDITIONAL FEATURES AVAILABLE AS OPTIONS	
MODEL *	DESCRIPTION		MODEL *	DESCRIPTION
6073	Receive-only printer	Automatic form feed Parallel interface	--	
(S)6074	Receive-only printer	Automatic form feed Parallel interface Compressed print	--	
6075	Receive-only printer	Automatic form feed Serial interface	1192-X	Alternate Character Set
(S)6076	Receive-only printer	Automatic form feed Serial interface Compressed print	1192-X	Alternate Character Set
6077	Keyboard send/receive terminal	Automatic form feed Serial interface Keyboard Numeric pad	1192-X	Alternate Character Set
(S)6078	Keyboard send/receive terminal	Automatic form feed Serial interface Numeric pad Compressed print Keyboard	1192-X	Alternate Character Set
6086	Receive-only printer	Automatic form feed Parallel interface NOVA/ECLIPSE programmed I/O controller Paper holder	1192-X	Alternate Character Set
6087	Receive-only printer	Automatic form feed Parallel interface Compressed print NOVA/ECLIPSE programmed I/O controller Paper holder		
6088	Receive-only printer	Automatic form feed Parallel interface NOVA/ECLIPSE data channel controller Paper holder		
6089	Receive-only printer	Automatic form feed Parallel interface Compressed print NOVA/ECLIPSE data channel controller Paper holder		
S6073	Receive-only printer	Parallel interface	S1146	Quantity 5 of Automatic form feed
S6075	Receive-only printer	Serial interface	S1146	Quantity 5 of Automatic form feed
S6077	Keyboard send/receive terminal	Serial interface Keyboard	S1192-X	Quantity 5 of 1192-x
			S1146	Quantity 5 of Automatic form feed
			S1147	Quantity 5 of Numeric pad
			S1192-X	Quantity 5 of 1192-x
			1149A	Box of 12 ribbon cartridges (for all models)
			1149B	Quantity 5 of 1149A
			1149C	Quantity 50 of 1149A
			S1149A	Quantity 5 of 1149A
			1127A	Paper holder
			S1127A	Quantity 5 of 1127A

* Model numbers with an S prefix are available to Data General Corporation's independent resellers. Consult your salesman. In ordering alternate character sets use the following designators in place of X:

- A = Standard ASCII Font
- B = UK Character Font
- C = French Character Font
- D = German Character Font
- F = Swedish Character Font

DG-05510

Table 1.2 DASHER LP2 and TP2 printers

OVERVIEW

Printing Examples

Using its different features, an LP2 or TP2 printer can print in a variety of modes as shown. Software controls the majority of these output modes.

```
These are the character sets available on
DASHER LP2 and TP2 printers.

THE U.S. CHARACTER SET IS:
ABCDEFGHIJKLMNPOQRSTUVWXYZ
abcdefghijklmnopqrstuvwxyz
1234567890!@#%&*()_+`^~{|}\|;:/'"0,<.>/?

The FRENCH character set is:
ABCDEFGHIJKLMNPOQRSTUVWXYZ
abcdefghijklmnopqrstuvwxyz
1234567890!@#%&*()_+`^~'9ù;:'"èè,<.>/?

The GERMAN character set is:
ABCDEFGHIJKLMNPOQRSTUVWXYZ
abcdefghijklmnopqrstuvwxyz
1234567890!@#%&*()_+`^BAÜö;:'"üü,<.>/?

The SWEDISH character set is:
ABCDEFGHIJKLMNPOQRSTUVWXYZ
abcdefghijklmnopqrstuvwxyz
1234567890!@#%&*()_+`eüÅÄö;:'"äü,<.>/?

The U.K. character set is:
ABCDEFGHIJKLMNPOQRSTUVWXYZ
abcdefghijklmnopqrstuvwxyz
1234567890!@#%&*()_+`^~{|}\|;:/'"0,<.>/?

DATA GENERAL CORP.
Westboro, MA

DG-04834
```

Figure 1.3 International Character Sets

Code Reception

A DASHER LP2 or TP2 printer receives information from a computer or communications line. DASHER TP2 printers can transmit as well as receive information. This information is represented by 7-bit ASCII codes. The 128 characters in the standard ASCII set consist of 96 upper and lower case alphanumeric punctuation, and graphic characters as well as 32 control codes. If a printer receives an alphanumeric code, it prints the corresponding character. If it receives a valid control code, it performs the specific function defined by the code. If, however, the printer receives one of the control codes it does not use, it ignores that code.

A printer can store up to 1400 characters in its buffer. Characters enter the buffer from either a parallel interface (DASHER LP2 printers) or a serial interface (DASHER TP2 printers). Both types of interfaces are able to signal the computer or communications system that the buffer is full.

This is an example of the DASHER LP2 and TP2 printers' capabilities. The text you are reading is printed using normal width characters at 6 lines per inch vertical spacing.

This is an example of the DASHER LP2 and TP2 printers' capabilities. The text you are reading is printed using normal width characters at 8 lines per inch vertical spacing.

This is an example of the DASHER LP2 and TP2 printers' capabilities. The text you are reading is printed using elongated width characters at 6 lines per inch vertical spacing.

This is an example of the DASHER LP2 and TP2 printers' capabilities. The text you are reading is printed using elongated width characters at 8 lines per inch vertical spacing.

This is an example of the DASHER LP2 and TP2 printers' capabilities. The text you are reading is printed using compressed width characters at 6 lines per inch vertical spacing.

This is an example of the DASHER LP2 and TP2 printers' capabilities. The text you are reading is printed using compressed width characters at 8 lines per inch vertical spacing.

This is an example of the DASHER LP2 and TP2 printers' capabilities. The text you are reading is printed using elongated compressed width characters at 6 lines per inch vertical spacing.

This is an example of the DASHER LP2 and TP2 printers' capabilities. The text you are reading is printed using elongated compressed width characters at 8 lines per inch vertical spacing.

Compressed Print underscores

Regular Print underscores

Compressed Elongated Print underscores

Elongated Print underscores

DG-04833

Figure 1.4 Print Spacing

The parallel interface controls a special hardware signal which tells the computer system when there is room in the buffer for a character. This is consistent with most line printer interfaces. As a result, the programmer need not worry about overflowing the buffer when programming a DASHER LP2 printer.

The serial interface is equipped with a number of methods of preventing the buffer from overflowing. It can tell the communications system to stop transmitting data via a hardware signal (for local connections), or by transmitting

OVERVIEW

special control characters (full duplex).

While receiving codes, the printer scans those codes already in the buffer to determine the fastest way to print each line. If the buffer becomes filled, the printer uses one of the methods discussed above to stop the system from transmitting codes. When the buffer is half empty, the printer can accept additional codes.

Printers respond to three types of information:

- Printing Character Codes - which result in a character being printed.
- Control Codes - single codes which control special functions.
- Escape Sequences - sequences of codes (beginning with an escape) which control certain functions.

Printing Character Codes

The printing characters include all the upper and lower case alphanumeric characters as well as graphic, punctuation, and space characters. Up to 132 characters may be printed on each line. If more than 132 characters are received without a line terminator, the line is truncated or a fault may occur, depending on the mode of operation. Newlines (012₈), Vertical Tabs (013₈), Form Feeds (014₈), and Carriage Returns (015₈) are all considered line terminators.

Control Codes

A printer recognizes a number of control codes it receives as commands to perform specific operations. The control codes and their effects are listed in Table 1.3.

Name	Mnemonic	Control Code (Octal)	Effect of Codes Received
Bell	BEL	007	Sounds audible tone.
Back Space	BS	010	Print head moves back one character position. (Only when online)
Horizontal Tab	HT	011	Print head moves to next horizontal tab stop. If no tab is set, the command is ignored.
Newline (Line Feed)	NL	012	Terminates the present line, advances the paper one line, and either: a) determines the fastest way to print the next line (if it is complete), or b) performs a carriage return and prints any character from left to right.
Vertical Tab	VT	013	Paper advances to next tab stop. If no tab is set, a carriage return command is substituted and no paper motion occurs.
Form Feed	FF	014	Paper advances to the top of the next form. If the automatic form feed option is not installed, a carriage return command is substituted and no paper motion occurs.
Carriage Return	CR	015	Carriage returns to the left-hand margin.
Shift Out	SO	016	Selects alternate character set. (Model 1192 Option)
Shift In	SI	017	Selects standard character set.
Escape	ESC	033	Denotes the beginning of a command sequence.

Table 1.3

Escape Sequences

A number of functions on a printer may be controlled by special sequences of codes called escape sequences.

- Horizontal and vertical tabbing
- Elongated characters
- Underscoring
- Plotting
- Resetting the printer
- Compressed printing (option)
- Down line loading a character set

An Escape code (033₈), defines the beginning of these sequences while subsequent codes define the particular function to be performed. If no valid code follows the Escape code (or an option is not installed), the Escape code is ignored and subsequent codes produce the standard effect. If the ESCAPE DISABLE switch on the secondary control panel is in the DISABLE position, all Escape codes are ignored and subsequent codes are printed.

Escape Seq.	Octal Codes	Function
ESC 1	033 061	Sets a horizontal tab at the current printhead position.
ESC 2	033 062	Clears a horizontal tab from the current printhead position.
ESC E #..CTRL-O	033 105 #..000	Sets horizontal tabs at the column positions specified by the octal number(s) #. All previous tabs are cleared.
ESC E CTRL-O	033 105 000	Clears all horizontal tabs.
ESC 5	033 065	Sets a vertical tab at the current line position.
ESC 6	033 066	Clears a vertical tab from the current line position.
ESC F #..CTRL-O	033 106 #..000	Sets vertical tabs at the line positions specified by the octal number(s) #. All previous tabs are cleared.
ESC F CTRL-O	033 106 000	Clears all vertical tabs.
ESC <	033 074	Selects elongated printing for subsequent characters.
ESC =	033 075	Clears elongated printing for subsequent characters.
ESC >	033 076	Selects the compressed printing mode.
ESC ?	033 077	Selects the normal print mode.
ESC a	033 141	Starts underscoring subsequent characters.
ESC b	033 142	Stops underscoring subsequent characters.
ESC c	033 143	Performs a master reset.
ESC d	033 144	Selects plot mode.
ESC e	033 145	Deselects plot mode.
ESC Y...*	033 131	Beginning of character set load sequence (see DGC 014000094).
ESC N Starting Character Set Address*	033 116 --- ---	Selects down line loaded character set (see DGC # 014000094).
ESC O	033 117	Deselects a down line loaded character set.

Table 1.4

Code Transmission

Only TP2 printers are capable of transmitting data to a computer. When enabled (using jumpers), TP2 printers transmit two control codes which act as a software busy signal.

*8 data bit controllers only

Code Name	Mnemonic	Control Code	Effect
Device Control	DC1	021 ₈	Indicates that the character buffer has room for more character.
Device Control	DC3	023 ₈	Indicates that the character buffer is full.

Table 1.5

In addition to the software busy feature, the keyboard on keyboard send receive (KSR) terminals can generate all the ASCII codes from 0 to 177 (octal). See Appendix A for the keys and key combinations which generate these codes.

Major Assemblies

DASHER LP2 and TP2 printers contain a number of basic assemblies. All models contain the following:

- **Carriage assembly** - moves the printhead horizontally in front of the paper and senses when the printhead should fire.
- **Paper feed assembly** - moves the paper vertically up through the carriage assembly.
- **Power supply** - provides the necessary supply voltages for the logic, printhead, and motors.
- **Main control board** - contains a microNOVA microprocessor and its related control circuitry. The microprocessor controls and monitors the printer's operation.
- **Driver board** - contains the circuitry which provides power for the control signals, allowing them to drive the motors and the printhead. It also contains the sensing circuitry which converts motion into logic signals.
- **Primary control panel** - contains three frequently used control switches and indicator lights.
- **Secondary control panel** - contains a number of less frequently used control switches.

All DASHER TP2 printers have an option board, which contains the serial interface and other TP2 printer options.

Keyboard send-receive TP2 printers have a keyboard, containing a typewriter style keyboard, a numeric pad, and a modified primary control panel.

OVERVIEW

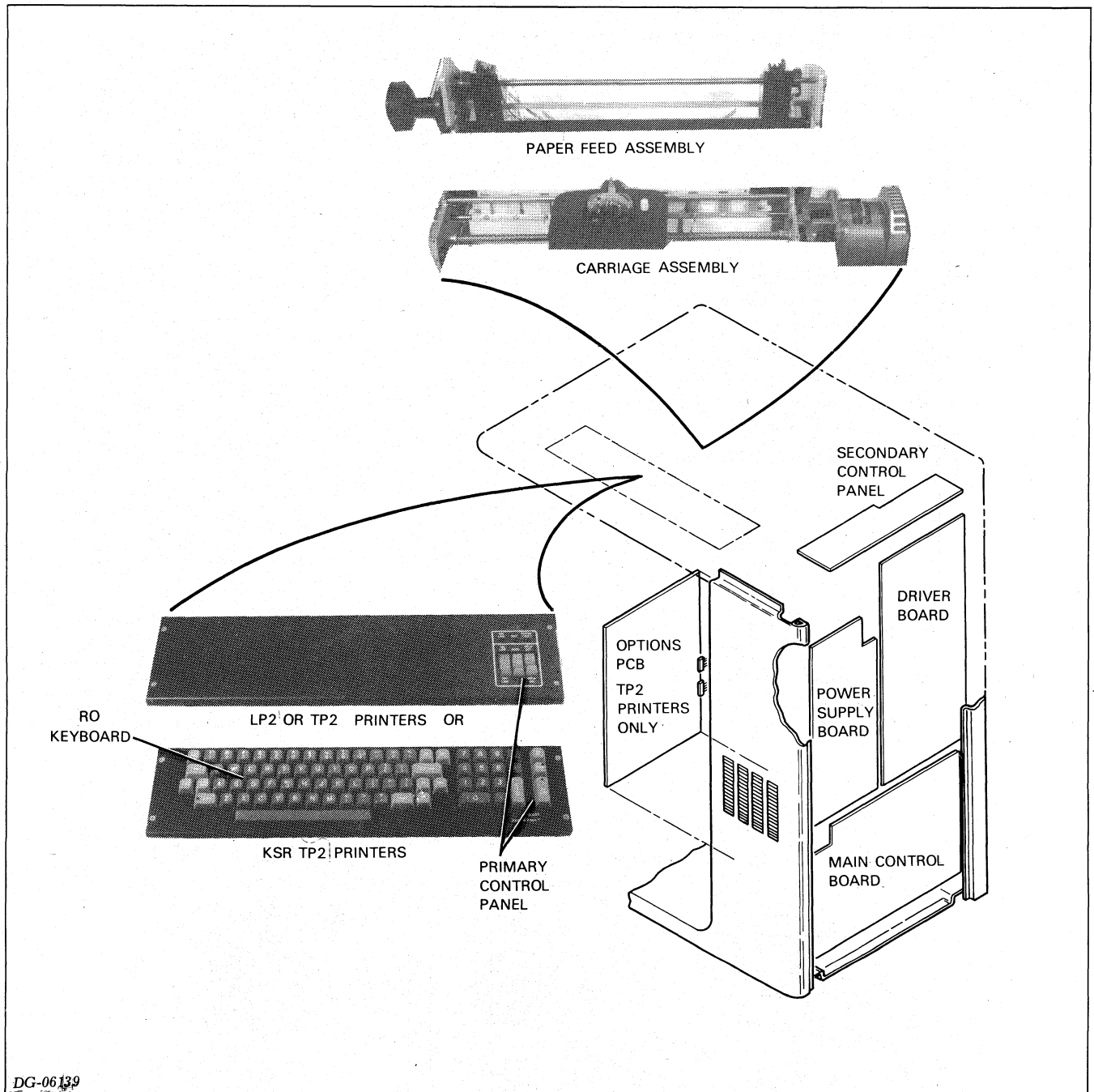

DG-06139

Figure 1.5 DASHER LP2 and TP2 Major Assemblies

Both the carriage assembly and the paper feed assembly may be broken down into a number of subassemblies.

Carriage Subassemblies

- **Carriage** - supports the printhead, allowing it to move horizontally (left or right) in front of the paper.
- **Carriage stepping motor** - driven by logic on the driver board, turns the leadscrew which moves the printhead.
- **Home transducer** - tells the microprocessor when the carriage is positioned at the left-hand margin.

- **Lead screw** - translates the carriage stepping motor's circular motion into the carriage's linear (horizontal) motion.
- **Printhead** - contains nine wires, in a vertical column, which fire as the printhead moves across the page. These wires force the inked ribbon against the paper.
- **Platen** - gives the wires in the printhead something to press against.
- **Position transducers and timing disc(s)** - tells the microprocessor how much the carriage moves and when to fire the printhead wires.

- **Ribbon cartridge** - contains an inked continuous ribbon.
- **Ribbon drive gearbox** - advances the ribbon using the motion of the carriage.
- **Ribbon drive cable** - turns a drive capstan on the ribbon drive gearbox when the carriage moves.

Paper Feed Subassemblies

- **Out of paper switch** - tells the microprocessor when the printer runs out of paper.
- **Paper feed stepping motor** - driven by the logic on the driver board, provides the motion to the assembly which moves paper through the printer.
- **Paper feed tractors** - driven indirectly by the stepping motor, support paper and advance it through the printer.
- **Paper movement transducer**- tells the microprocessor when and how much the paper moves.
- **Paper tension bar** - keeps the paper flat against the platen.

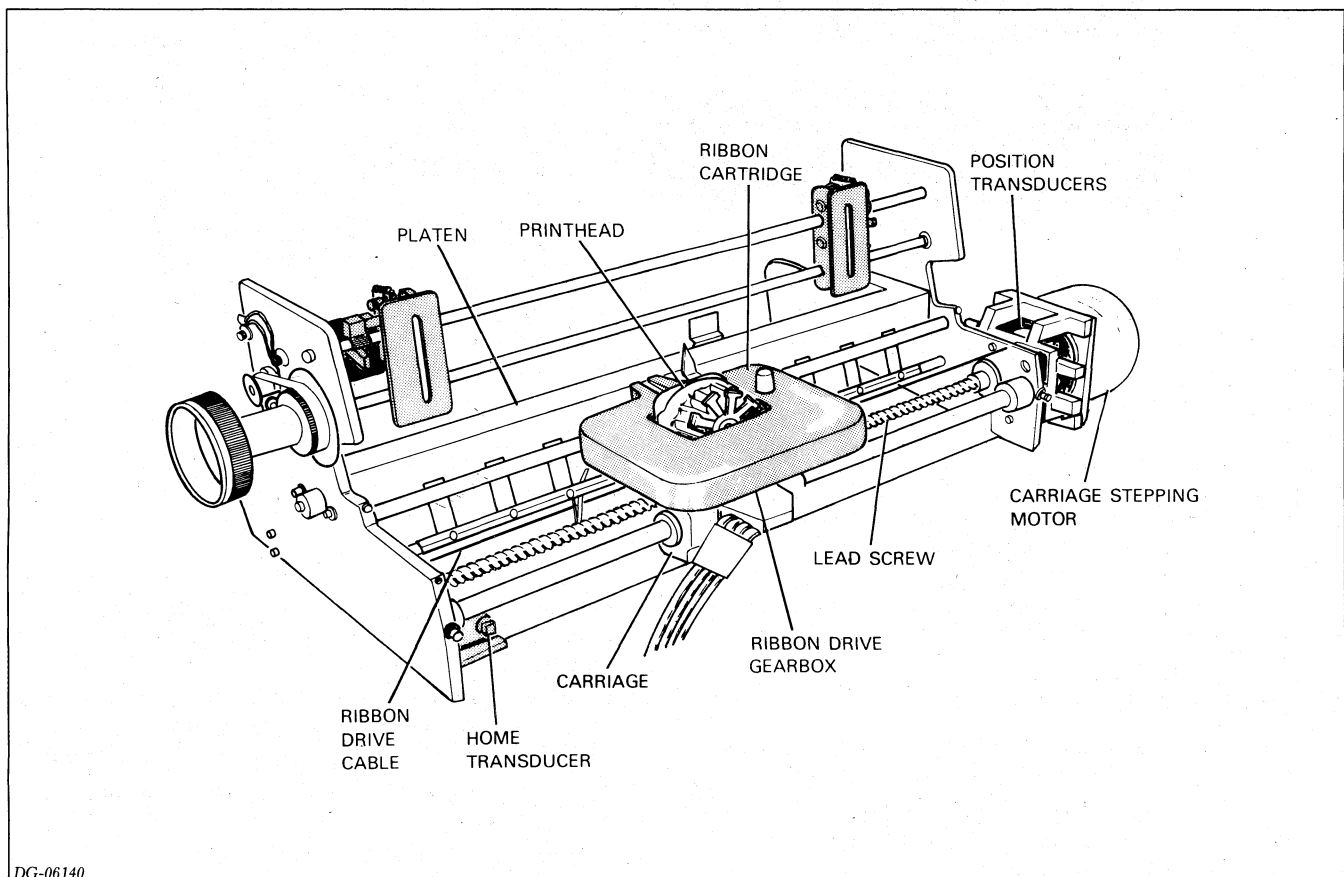

DG-06140

Figure 1.6 Carriage Subassemblies

OVERVIEW

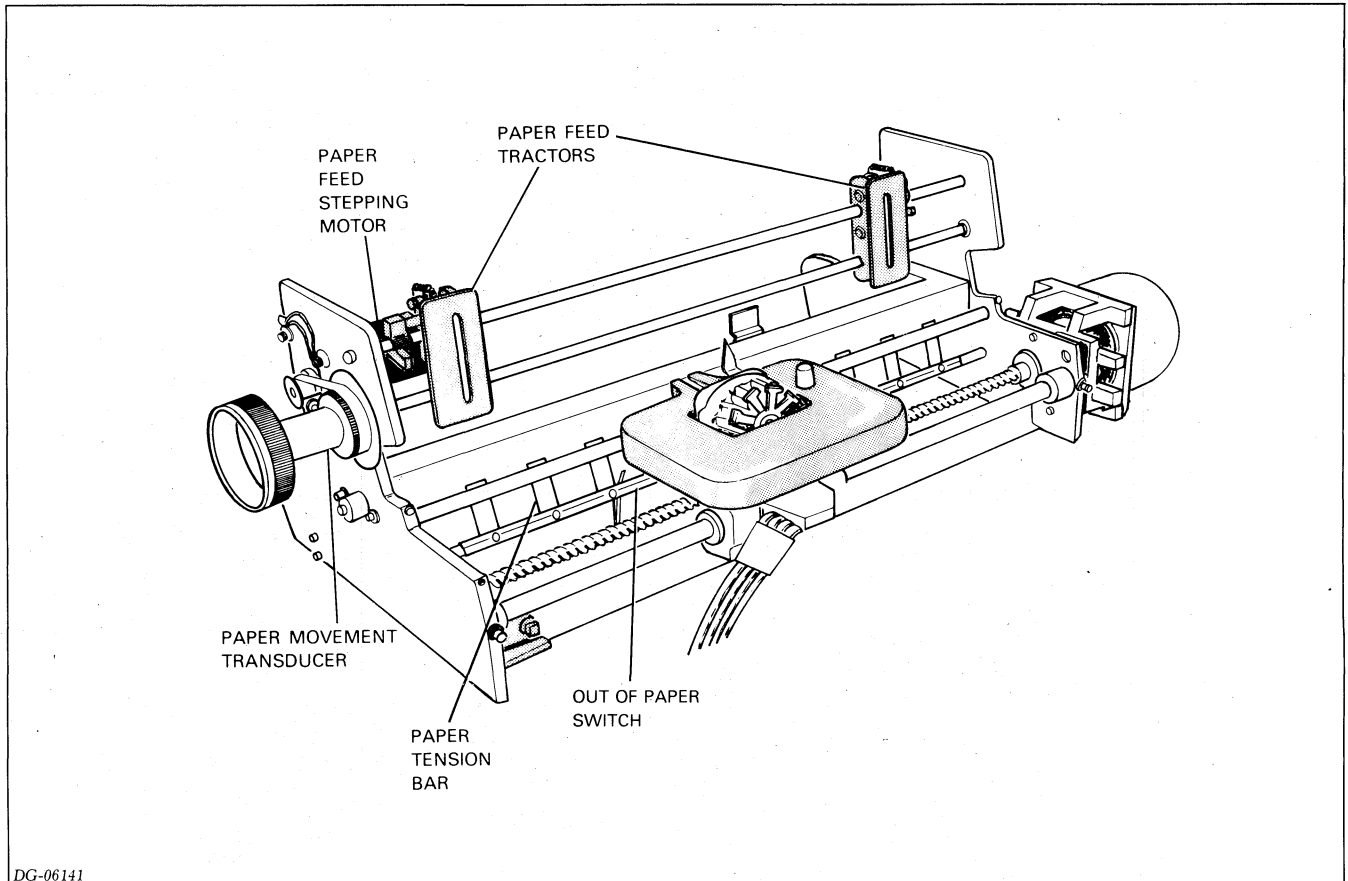

DG-06141

Figure 1.7 Paper Feed Subassemblies

Related Documentation

The following is a list of related documentation:

- **Manuals:**

- 014000093 *DASHER LP2 and TP2 Printers Operator's Manual*
- 014000094 *DASHER LP2 and TP2 Printers User's Manual*
- 016000647 *DASHER LP2 and TP2 Printers Illustrated Parts Breakdown*
- 043-001600 *Product Information Package (Fiche)*

- **Installation Data Sheets:**

- 010000195 *DASHER LP2 Printers models 6073, 6074, and S6073*
- 010000214 *DASHER TP2 Printers 6075 - 6078*

- **Part Numbers** of Circuit Boards and Related Documents, see Table 1.5.

- **External Cable Part Numbers** and Wire Lists:

See Appendix D.

- **Internal Cable Part Numbers** and Locations:

See Appendix E.

Circuit Board	Part Number	Artwork Number	Logic Prints	IPL
LP2 Main Control Board	005009503	107000897	001001220	016000541
	005013777	107001367	001001693	016000872
TP2 Main Control Board	005014954	107001367	001001693	016000872
	005009505	107000832	001001226	016000540
Power Supply Board	005009514	107000886	001001223	016000542
	005013887	107001372	001002600	016000881
Options Board	005009517	107000914	001001225	016000615

Table 1.6

Chapter 2

OPERATOR CONTROLS

Power Switch

This two-position switch is located on the inner side of the pedestal and operates as follows:

UP/ON - The power is turned on, the fan runs, and the printhead returns to the beginning of the line.

DOWN/OFF - The power and the fan are turned off.



Figure 2.1 Power Switch

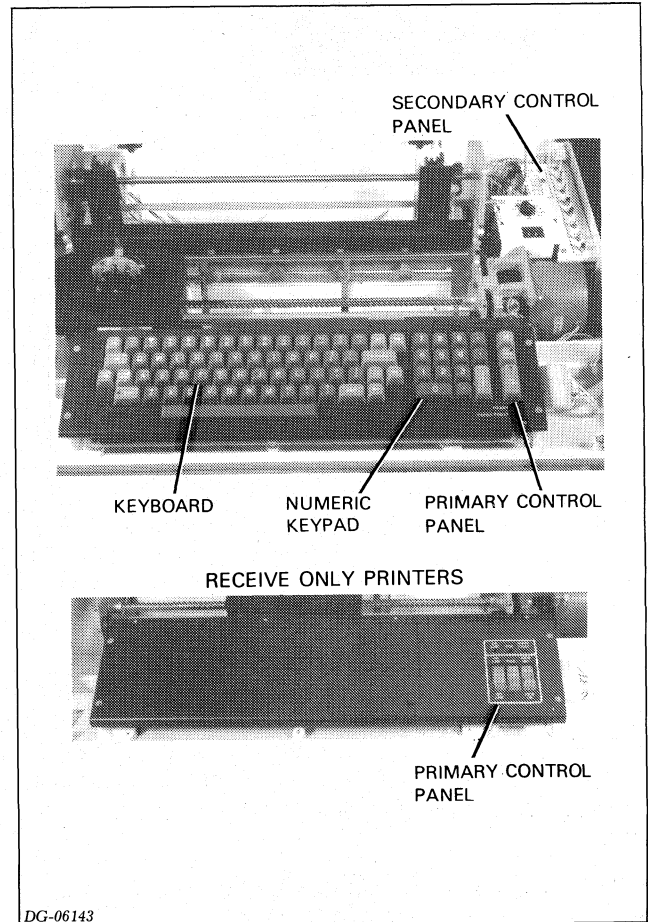
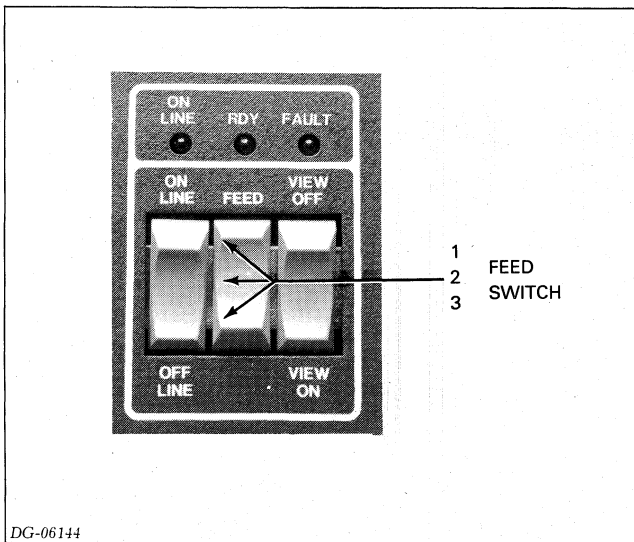

Figure 2.2 Control Panels

Primary Control Panel, RO Printer



DG-06144

Figure 2.3 Primary Control Panel, RO Printer

ON LINE (indicator light) - When lit, the printer is able to accept characters. When not lit, either the printer is not able to accept characters (i.e., its character buffer is full), it is offline, it is not powered up, or there is a fault condition (depending on the firmware revision).

RDY (ready indicator light) - When lit, the printer is able to accept characters. When not lit, either the printer is not able to accept characters (i.e., its character buffer is full), it is offline, it is not powered up, or there is a fault condition.

NOTE: The RDY light will blink on and off during normal operation.

FEED (three-position switch) - Pressing the switch to position 1 advances the paper one line. Position 2 is the normal. Pressing the switch to position 3 advances the paper to the top of the next form if the automatic form feed is installed. If the automatic form feed option is not installed, pressing the switch to position 3 advances the paper until you release the switch.

VIEW ON/OFF (two-position switch) - When in the VIEW ON position, the view feature is enabled. When in the VIEW OFF position, the view feature is disabled.

When this feature is enabled and there is a pause in printing, the printhead automatically moves several spaces to the right so you can see the last character printed. If the printhead is near the end of the line when there is a pause in printing, it moves to the left instead of the right.

FAULT (indicator light) - When lit, the printer is either out of paper, its paper feed mechanism is jammed, the ribbon cartridge is jammed, or the light indicates the existence of other hardware faults.

ON/OFF LINE (two-position switch) - When in the ON LINE position, the printer is under the computer's control. When in the OFF LINE position, it is not under the computer's control. However, if a fault condition exists, the printer can be offline (RDY indicator extinguished), even though the ON/OFF LINE switch is in the ON LINE position.

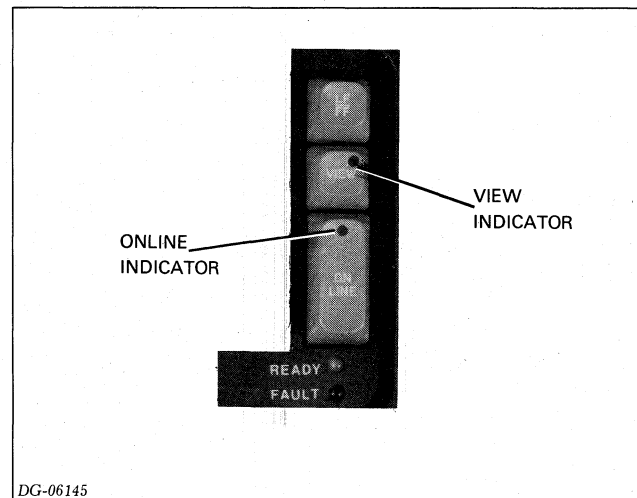

DG-06145

Figure 2.4 Primary Control Panel, KSR Terminal

VIEW (indicator light) - When lit, the terminal's view feature is enabled. When not lit, the feature is disabled.

ON LINE (indicator light) - When lit, the terminal is on line (under control of the computer). When not lit, it is off line, not powered up, or there is a fault condition.

READY (indicator light) - When lit, the terminal is able to accept characters. When not lit, either the printer is not able to accept characters (i.e., its character buffer is full), it is offline, not powered up, or there is a fault condition.

NOTE: The RDY light will blink off and on during normal operation.

FAULT (indicator light) - When lit, the terminal is either out of paper, its paper feed mechanism is jammed, the ribbon cartridge is jammed, or a checksum error occurs in a downline loaded character set.

LF/FF (momentary contact switch) - Pressing the switch for less than a second advances the paper to the next line. (Line Feed). If the automatic form feed option is installed, pressing the switch for more than a second advances the paper to the top of the next form (Form Feed). If the automatic form feed option is not installed, pressing the switch for more than a second advances the paper at about one second intervals until the switch is released.

VIEW (alternate action switch) - When pressed and the light glows, view mode is enabled. When pressed again and the light goes OFF, view mode is disabled.

OPERATOR CONTROLS

When this feature is enabled and there is a pause in printing, the printhead automatically moves several spaces to the right so you can see the last character printed. If the printhead is near the end of the line when there is a pause in printing, the printhead moves to the left instead of the right.

ON LINE (alternate action switch) - When pressed and the light glows, the terminal is connected to the computer or communications system. When pressed again and the light goes off, the terminal is disconnected from the system.

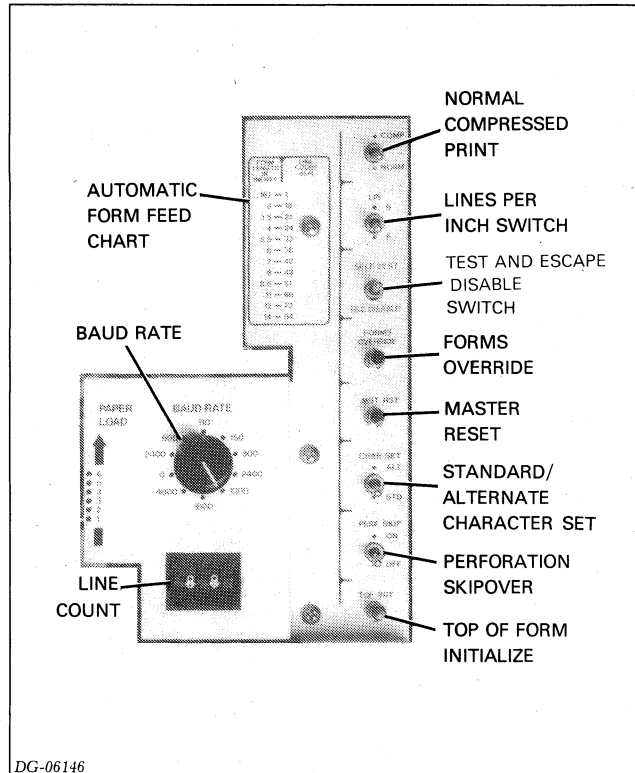

Figure 2.5 Secondary Control Panel

Secondary Control Panel

You control various features of your terminal through switches located on the secondary control panel. You can control the terminal by these switches while the terminal is off line. When you switch the terminal on line, it retains the last switch settings. Change the secondary panel's switch settings while the terminal is switched off line (except MST RST and ESCAPE DISABLE).

NORM/COMP (normal/compressed switch) - When in normal position, selects normal width characters. When in the compressed position, selects compressed width characters.

You can print up to 132 normal width characters/line on 15-inch wide forms or you can print up to 132 compressed characters/line on 9-inch wide forms. You can print elongated characters in both modes.

LPI (lines per inch switch) - In the 6 position, selects 6 lines/inch vertical spacing. In the 8 position, selects 8 lines/inch vertical spacing.

SELF-TEST/ESC DISABLE (three-position switch) - Depending on the switch position, performs as follows:

- Middle - The printer decodes escape sequences normally.
- ESCape/DISABLE - The printer does not decode escape sequences. Escape codes are ignored and subsequent codes are printed.
- SELF TEST - When off line, initiates the self-test diagnostic program.

Start the self-testing diagnostic as follows:

- 1-Switch your terminal off line.
- 2-Momentarily press the switch to the SELF TEST position.
- 3-Adjust the switches on the secondary control panel to reflect the functions you wish to test (COMP/NORM, LPI, CHAR SET, PERF SKIP, and LINE COUNT).
- 4-Switch the terminal on line.

The terminal should sequentially print the entire character set, 132 characters to the line. It should continue printing the character set at 180 cps (characters per second) until you press MST RST.

End the self-testing diagnostic by depressing MST RST (master reset).

FORMS OVERRIDE (pushbutton switch) - Depressing this switch, after you have run out of paper, allows printing another line of text. This switch is handy if you are in the middle of a job when paper runs out.

MST RST (Master Reset pushbutton switch) - Depressing this switch initializes (sets up) the terminal according to the switch settings of the primary and secondary control panels and clears the character buffer.

CHAR SET (Character Set switch) - When in the STD position, the terminal prints characters defined by the standard character set. When in the ALT position, the terminal prints characters defined by the alternate character set.

PERF SKIP (Perforation Skip-over switch) - When in the ON position, the terminal skips an inch between forms (the perforation). When in the OFF position, the terminal does not skip any space between forms.

BAUD RATE (rotary switch) - Selects the number of information bits which can be transmitted or received serially each second over a communications line. This switch is normally set when the unit is installed and not changed unless you connect the terminal to a different system.

AUTOMATIC FORM FEED - With this option you can return the printhead to the beginning of the line and advance the paper to the top of the next form all in one operation. A terminal can perform a form feed on forms up to 16.5 inches long.

Before you can use the automatic form feed, you have to set the form feed controls located on the secondary control panel. These controls include the TOF INIT (Top of Form Initialize) switch and the LINE COUNT switches. You set these switches as follows:

- 1-Switch the terminal off line.
- 2-Advance the paper manually or by pressing the Line Feed switch to the line you want initialized as the top of the form.
- 3-Set the line count wheels to the total number of lines between perforation on the form being used. If the Lines per Inch switch is set for 6, you may use the chart on the secondary panel to convert from form length to line count. If it is set for 8 lines per inch, the number of lines equals 8 multiplied by the form length (inches). Thus, the maximum form length is 12 inches for 8 lines/inch and 16.5 inches for 6 lines per inch.
- 4-Depress the Master RESET switch.
- 5-Depress TOF INIT.

Part 2 Installation and Troubleshooting



Chapter 3

HOW TO USE PART 2

Introduction

Part II of this manual consists of eight chapters which contain two types of information: troubleshooting procedures and reference material. You will want to use this section if you are:

- Installing and checking out a new printer
- Checking out a printer after performing the Preventive Maintenance Procedures outlined in SECTION IV, CHAPTER 2
- Repairing a printer

While these situations are different, many of the procedures required to check out and repair a printer are the same, as shown in the troubleshooting flowchart (Figure 3.1). This flowchart leads you through a logical sequence of fault isolation, using chapters 6 through 10 of this section. Chapters 4 and 5 provide support information.

To isolate a problem, you are asked to perform specific tests and interpret the printer's response. Since many of the tests can only exercise the printer's various functions, your interpretation of the results is used to answer pertinent questions or to select from lists of possible symptoms. Chapters 6 and 10 help you narrow down the list of field replaceable units suspected of failing.

When you isolate a problem, replace the failing unit. All replacement procedures are contained in Part IV, Chapter 15. Once the new unit is in place make sure you perform all the necessary adjustments in the proper order. A replacement/adjustment chart in Chapter 13 contains this information. Finally, you should make sure the printer is operating correctly by following the troubleshooting flowchart (Figure 3.1) once again.

Pre-Site Information

Before going to the customer's site for a repair call, make sure you know the model of printer which is failing. This will help ensure that you have the appropriate field replaceable units when you arrive. Additionally, try to get information from the customer that may give you a clue to the failing FRU. Ask the following questions:

- Does the printer operate at all ?
- What are the states of the various indicator lights ?
- How often does a problem occur and under what conditions ?

First Steps

Many problems may be located and corrected by a simple visual inspection. Among the things that may be checked are:

- The power cable, power switch, and circuit breaker
- The external cable connecting the printer to a computer system or modem. Be sure you have the correct cable (see Appendix D)
- The status of the printer's four indicator lights (see Chapter 5)
- The jumpering of all internal printed circuit boards (see Appendix C)
- The jumpering of the respective parallel interface or serial interface controller if connected to a Data General computer system (see DGC 014000605).

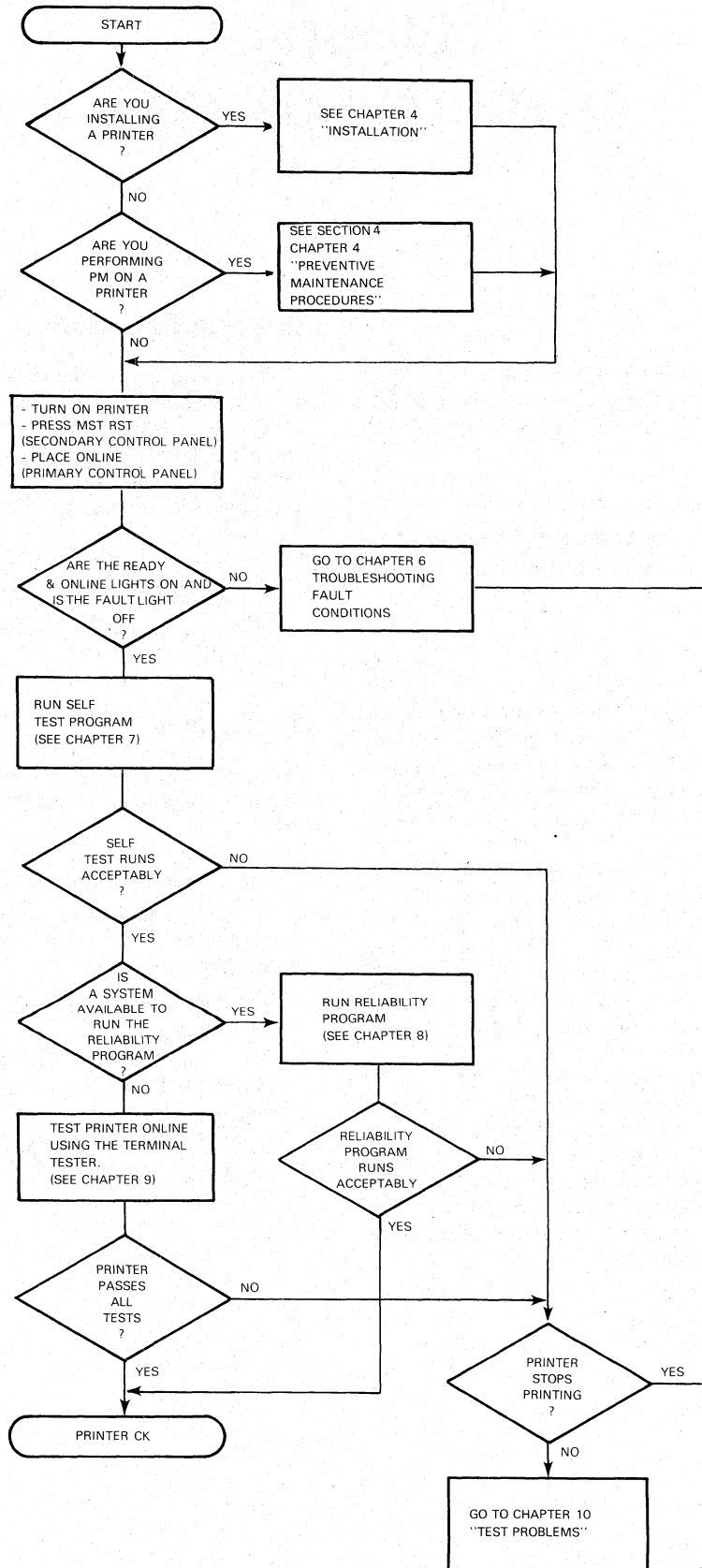

DG-06147

Figure 3.1 Troubleshooting Flowchart

Chapter 4 INSTALLATION

INTRODUCTION

This chapter tells you how to install a DASHER LP2 or TP2 printer. After these installation procedures are completed, continue with the check-out procedures outlined in figure 3.1.

CHOOSING A SITE

Figure 4.1 summarizes the environmental specifications for a DASHER LP2 or TP2 printer. These specifications should be consulted in selecting a site for a new printer.

Unpacking

Uncrate the printer and remove the shipping restraints as shown in the diagram. Make sure the four shipping bolts holding the print mechanism to the casing are removed. The four leg-levelers are contained in the plastic bag.

Checking for the Correct Hardware

Before proceeding further in the installation process, check to see that all the correct hardware is present. You should have the following:

- A DASHER LP2 or TP2 printer (model number is stamped on the cabling connector panel located on the rear side of the pedestal at its base).
- Either a 120 volt power cable (DGC #109000238) or a 220/240 volt power cable (DGC #109000240).

- The correct line printer controller (LP2 printers); OR an asynchronous serial interface controller, an available port on a multiline asynchronous controller, a port into communications equipment, or a modem (TP2 printers).

Line Printer Controller	DGC Part #	Installation Data Sheet
microProducts	005008448	010000126
Programmed I/O	005003564	010000199
Data Channel	005008096	010000199

2

- The proper external cable to connect the printer to the computer or communications system (see Appendix D).
- A ribbon cartridge and enough paper to run the offline and online test programs.

Jumpering

The main control board and the options board (TP2 printers only) contain hardware jumpers. Check Appendix C to be sure that the appropriate jumpers are inserted.

Cabling

There are two external cables: the power cable and the device cable. See Appendix D for information on selecting and attaching the appropriate cables.

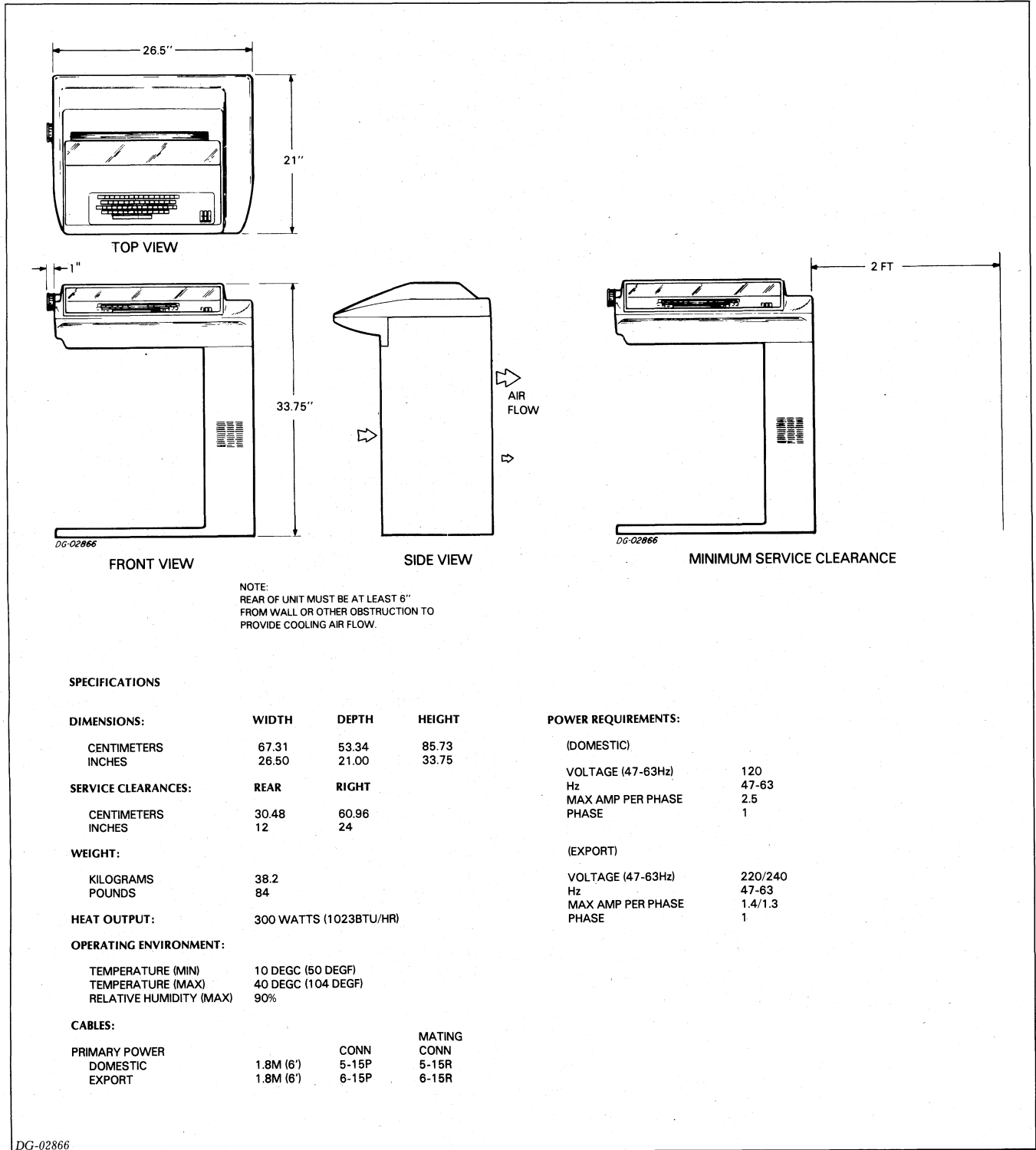

DG-02866

Figure 4.1 Site Specifications

INSTALLATION

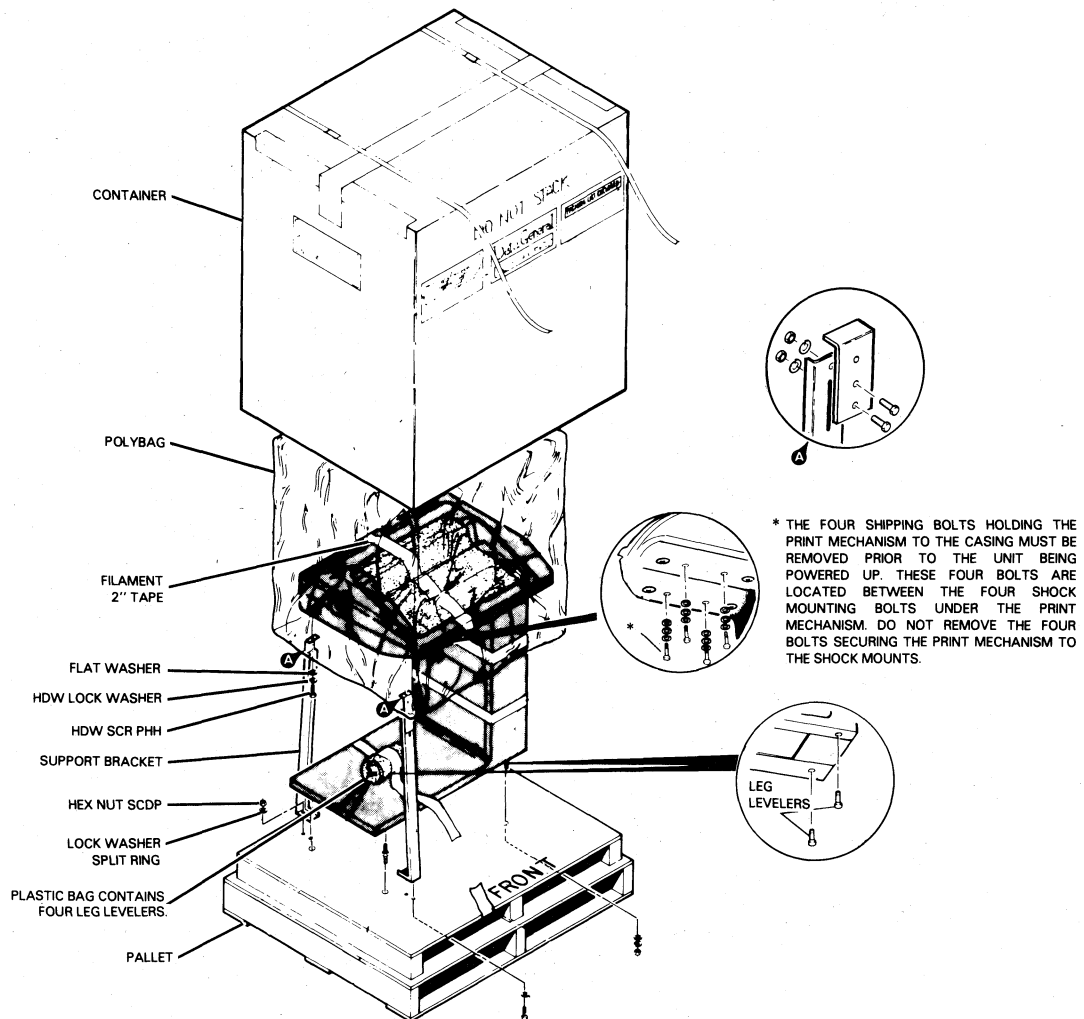

2

SHIPPING AND PACKAGE DATA					
Outside Dimensions			Weight (Gross)	Volume	Density
Length	Width	Depth			
in.	in.	in.	lbs.	cu ft.	lbs/cu ft.
cm	cm	cm	kg	cu m	kg/cu m
37	32.5	50	165	34.8	3.7
94	82.6	127	74	.98	60.2
SHIPPING SPECIFICATIONS			STORAGE SPECIFICATIONS		
Temperature Range	Relative Humidity	Maximum Altitude	Temperature Range	Relative Humidity	Maximum Period
°F / °C	(Non-condensing)		°F / °C	(Non-condensing)	
-40 to +149	0%/80%	50,000ft. 15,200m	-40 to +149	10%/90%	90 days
-40 to +65			-40 to +65		

DG-03289

Figure 4.2 Unpacking Information



Chapter 5

FAULT DETECTORS

Introduction

A circuit breaker and a system of fault interlocks protect DASHER LP2 and TP2 printers. These interlocks serve to disable operation of the printer if certain components fail. Several of the fault interlocks incorporate indicator lights to facilitate troubleshooting. There are four such indicator lights:

- Two on the primary control panel - the RDY light - the FAULT light
- One on the power supply board - the HEAD FAULT light
- One on the main control board - the RUN light.

The location of each of these indicator lights is shown in the figure.

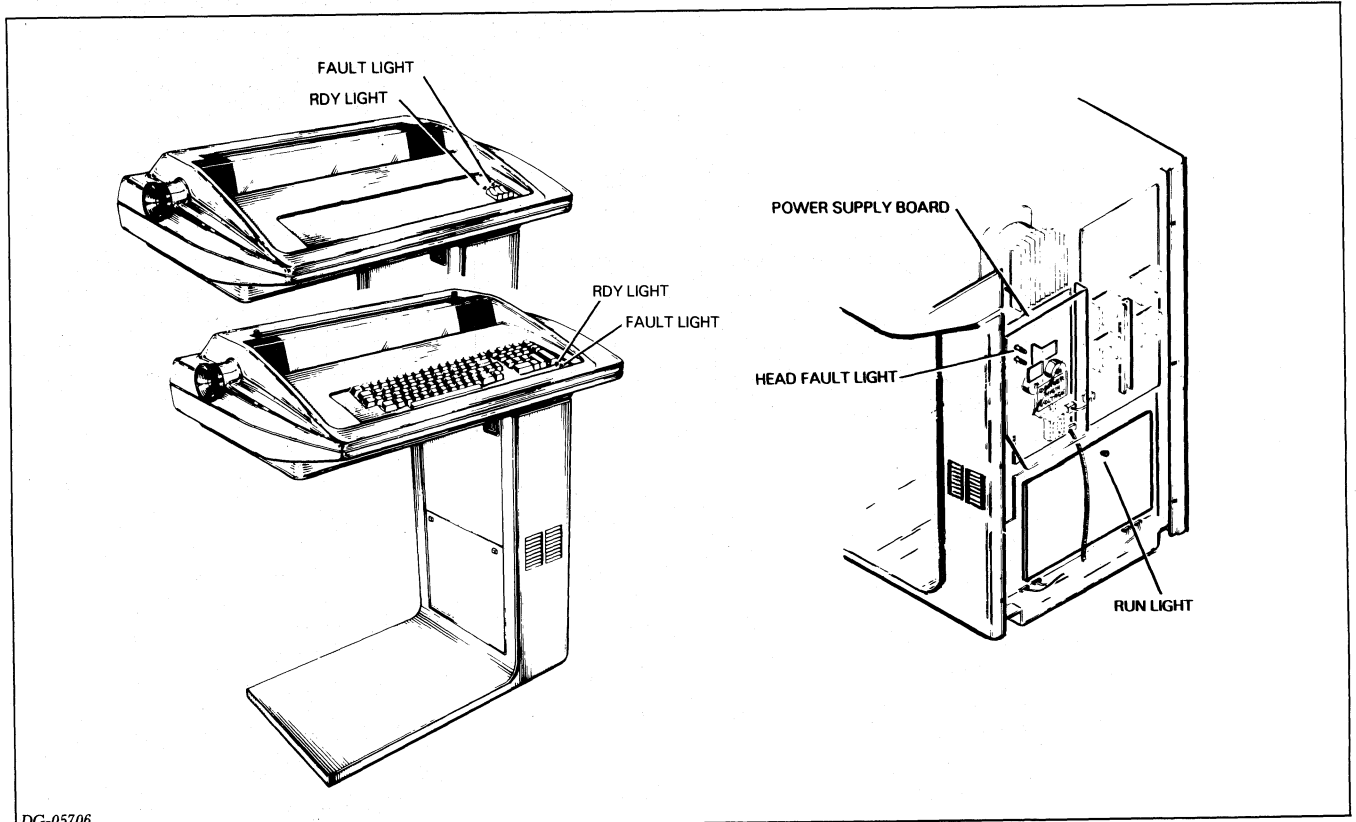

DG-05706

Figure 5.1 Fault Detection Lights

Power Line Circuit Breaker

A circuit breaker protects a printer from overcurrent situations. A portion of the circuit breaker pops out in the event of a short. Reset the breaker (with the power switch OFF) by pressing in the cylinder. If a breaker will not reset, wait 5 minutes and try again. DO NOT FORCE the breaker to reset or you may damage it.

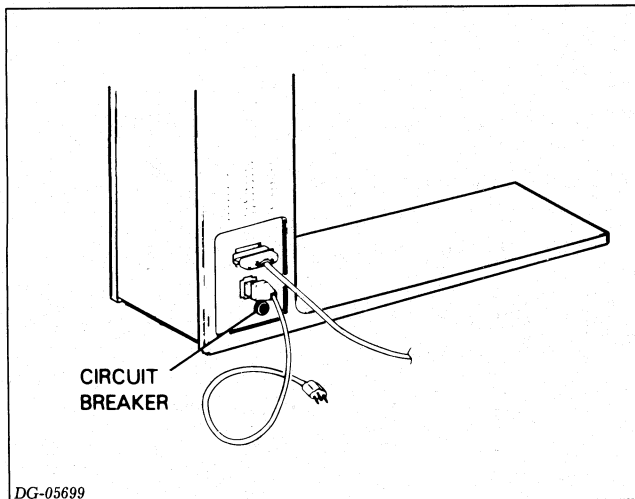

Figure 5.2 Power Line Circuit Breaker

RDY (Ready) Light

The RDY light indicates the status of the printer's character buffer as well as the existence of any fault conditions. The light operates only when the printer is online. Normally, the light goes off when the character buffer is filled. The light comes on again when the buffer becomes half empty. The RDY light also goes off if a fault exists, warning you that you may no longer operate the printer.

Fault Light

The fault light comes on when either :

- The printer runs out of paper
- The paper has not advanced the correct distance (paper jam)
- The carriage jams
- A checksum error is detected after receiving a down-line-loaded character set

Once a problem is diagnosed and corrected, the FAULT light should go out when you press the MST RST button (located on the secondary control panel).

Note, however, that pressing MST RST clears any characters in the buffer.

Head Fault Light

When this light is off, the printhead is operating normally. When lit, the power supply is shut down because excessive current was detected in one or more of the printhead windings. To reset the circuit, you must turn the main power switch off for at least 1 minute. Head faults usually occur due to a problem in the printhead driving circuitry, a short in the printhead, or a short in the ribbon cable connecting the printhead to the driver board.

Run Light

When this light is on, the printer has properly executed the first part of its power-up and initialization sequence. If this light does not come on after powering-up the printer and/or pressing the MST RST switch, the printer is not initializing correctly. To correct the problem, see Chapter 6 of this section.

Chapter 6

POWER-UP AND FAULT TROUBLESHOOTING

Introduction

This chapter will help you repair a DASHER LP2 or TP2 printer which:

- Does not power-up correctly
- Does not initialize correctly after pressing the MST RST button on the secondary control panel
- Stops while printing.

If you are troubleshooting problems detected while the printer is printing, see Chapter 10.

Before continuing, make sure you understand the meanings and locations of the various fault indicator lights. This information is summarized in Chapter 5.

When you find a failing field replaceable unit, replace it, following the replacement procedure given in Part IV, Chapter 15, and perform any of the indicated adjustment procedures given in Chapter 16. Chapter 13 contains a replacement/adjustment chart (Figure 13.1) indicating the various adjustments that should be performed when a part is replaced.

Normal Power-Up or Initialization Response

An initialization sequence is performed each time a DASHER LP2 or TP2 printer is powered up, the MST RST button on the secondary control panel is depressed, or a reset escape sequence is received. This causes the printer to:

- Move the printhead to the left-hand margin
- Sound an audible tone
- Clear the character buffer
- Initialize the print characteristics according to the settings of the secondary control panel

Placing the printer online following the completion of this sequence should cause the RDY (or READY) and ONLINE lights to come on and the FAULT light to remain off. If any other response is observed, place the printer offline and follow through the flowchart for power-up and fault troubleshooting (Figure 6.1) to determine the cause of the problem.

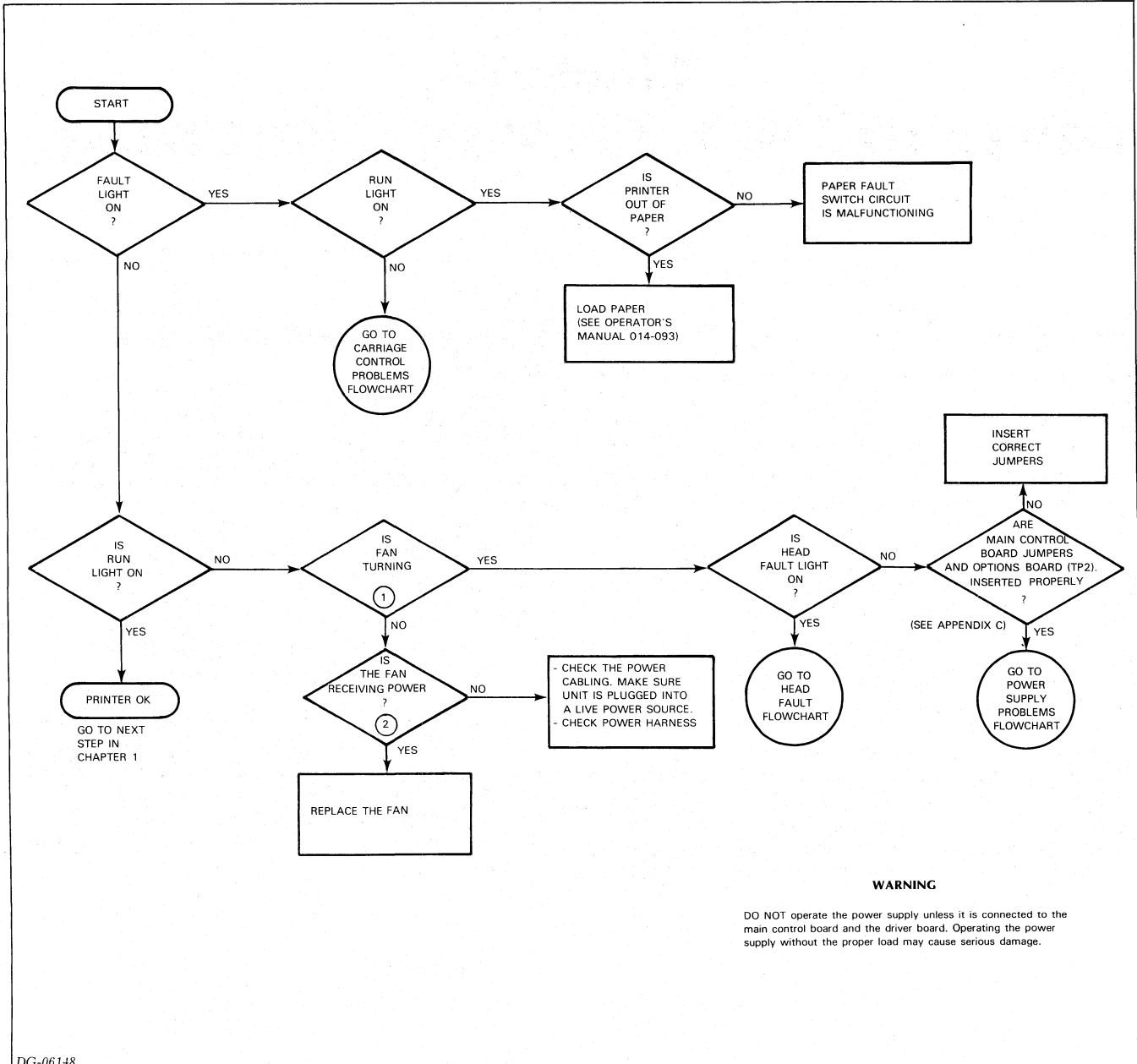

WARNING

DO NOT operate the power supply unless it is connected to the main control board and the driver board. Operating the power supply without the proper load may cause serious damage.

DG-06148

Figure 6.1 Flowchart for Power-Up and Fault Troubleshooting

POWER-UP AND FAULT TROUBLESHOOTING

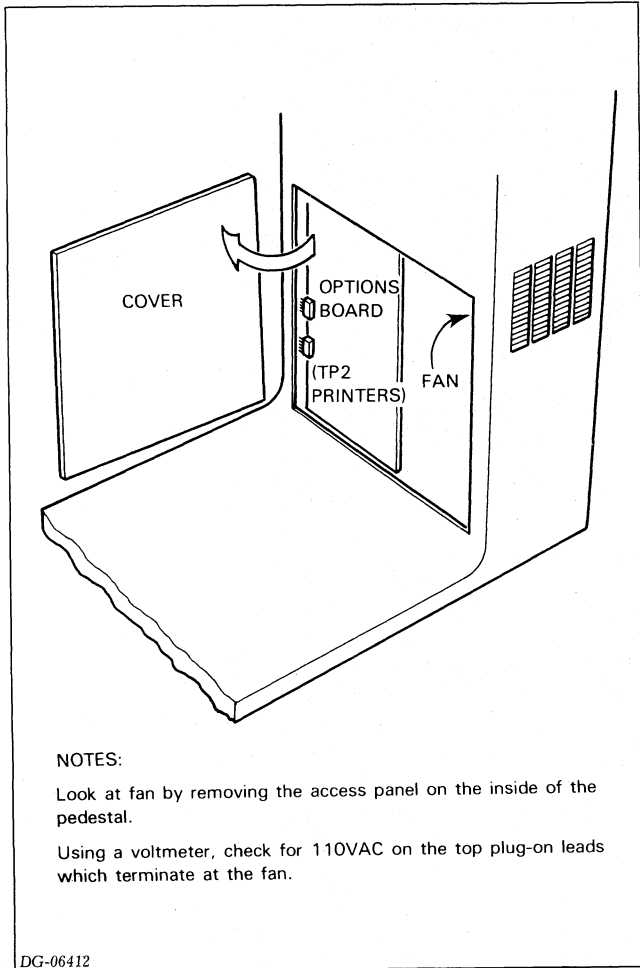

Figure 6.2 Fan location

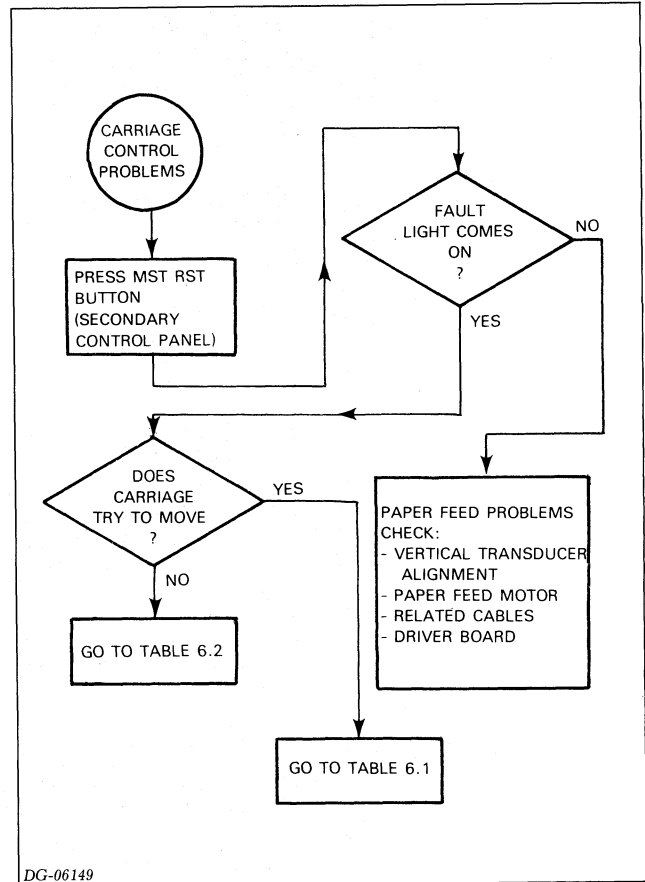

Figure 6.3 Flowchart for Carriage Control Problems

SYMPTON	PROBABLE CAUSE	CORRECTIVE ACTION
Carriage Moves in Jerking motions	a) Carriage position transducers and/or code disc(s) are dirty. b) Carriage position transducers are out of adjustment. c) Carriage is binding d) Cable connecting the carriage position transducers to the driver board is disconnected or bad. e) Transducer detect logic on driver board is bad. f) Transducer control logic on main control board is bad. g) Transducers are bad.	a) Clean position transducers and code disc(s) (see step 4 of the Preventive Maintenance Procedures, Section IV, Chapter 2). b) Perform the Carriage Sector Disc(s) Timing Adjustments: Parts I and II, and Print Transducer Adjustment. c) Check to see that the following parts are not jamming: - ribbon cartridge - ribbon drive gearbox - carriage rail bearings d) Check cable (normal print cable goes to J9, compressed cable goes to J8). e) Replace the driver board. f) Replace main control board. g) Replace the transducers.
Carriage moves to right margin at a low speed.	a) Home transducer is dirty. b) Home transducer cable is unplugged or bad. c) Home detect logic on driver board is bad. d) Home detect logic on main control board is bad.	a) Clean the home transducer (see step 4 of the Preventive Maintenance Procedures; Section IV, Chapter 2) b) Check cable attaching to J7 on the driver board. c) Replace the driver board. d) Replace the main control board.

Table 6.1 Faulty Carriage Motion

SYMPTON	PROBABLE CAUSE	CORRECTIVE ACTION
Carriage motor does not move.	a) Cable connecting the carriage motor to the driver board is unplugged or bad. b) Driver board motor circuitry is bad. c) Control board circuitry is bad. d) Power supply not providing motor driving voltages (16VDC and/or 48VDC). e) Carriage motor is bad.	a) Check cable (goes to connector J1 on driver board). b) Replace driver board. c) Replace main control board. d) Check power supply for 16VDC and 48VDC. (connector J11, see Power Supply Checkout Flowchart. e) Replace the carriage motor.

Table 6.2 Carriage Motor Does Not Move

POWER-UP AND FAULT TROUBLESHOOTING

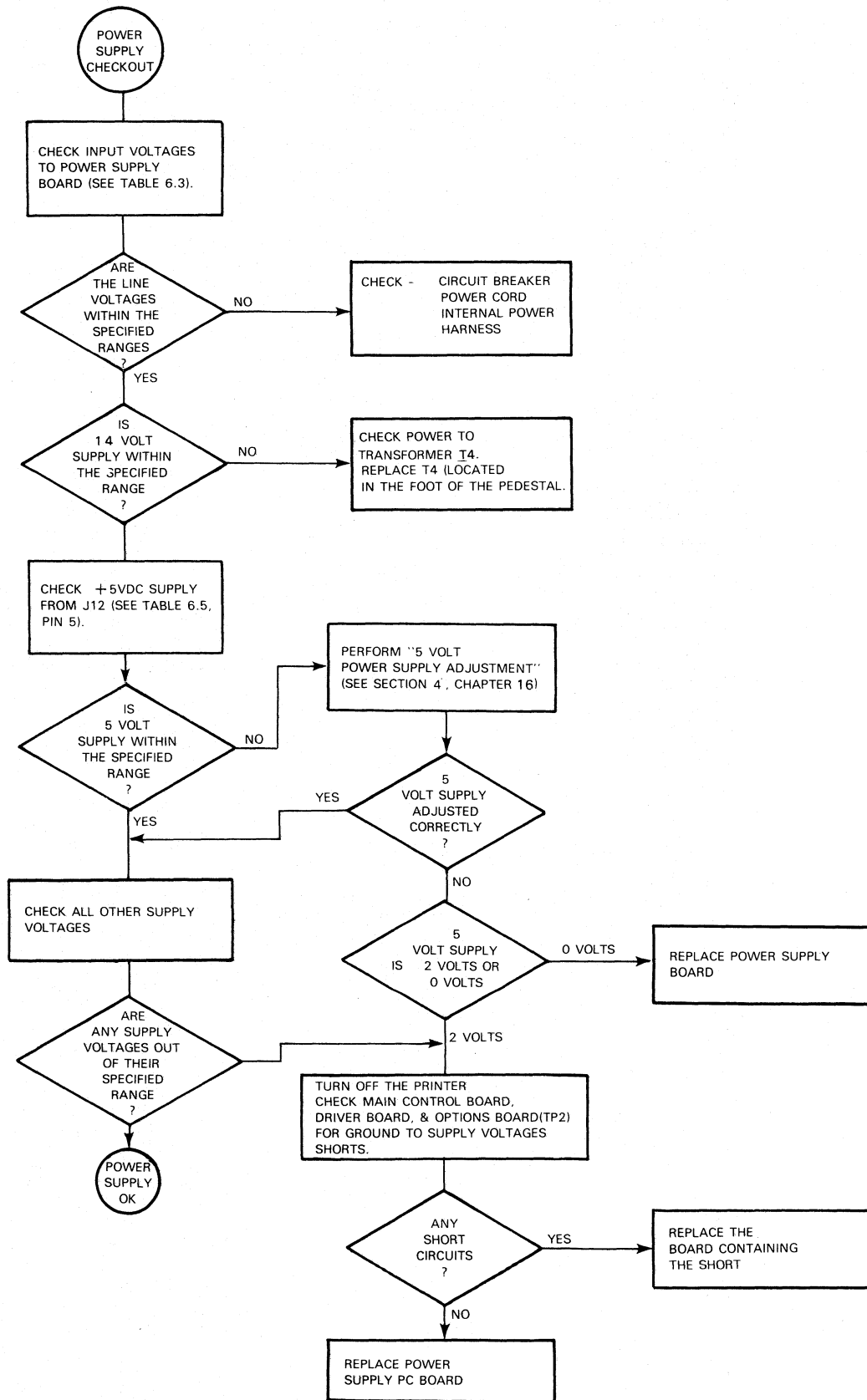

DG-06151

Figure 6.4 Flowchart for Power Supply Checkout

Pin	Voltage	Min.	Max.	
1	120 VAC (neutral)	---	---	120 volt operation (use line cord DGC # 109-238)
2	15 VAC	---	---	
3	120 VAC (neutral)	---	---	
4	15 VAC	12.8	16.5	
5	120 VAC (line)	102	132	
6	Ground	---	---	
1	220/240 VAC (line)	196	253	220 or 240 volt operation (use line cord DGC # 109-237)
2	15 VAC	---	---	
3	Neutral	102	132	
4	15 VAC	12.8	16.5	
5	220/240 VAC (line)	196	253	
6	Ground	---	---	

Table 6.3 Connector J10 Power Supply Input Voltages

Pin	Voltage	Min.	Max.
1	No Connection		
2	+5 VDC	+5.0	+5.1
3	+48 VDC	+43.0	+53.0
4	Ground	---	---
5	+16 VDC	---	---

Table 6.4 Connector J11 - To Driver Board

POWER-UP AND FAULT TROUBLESHOOTING

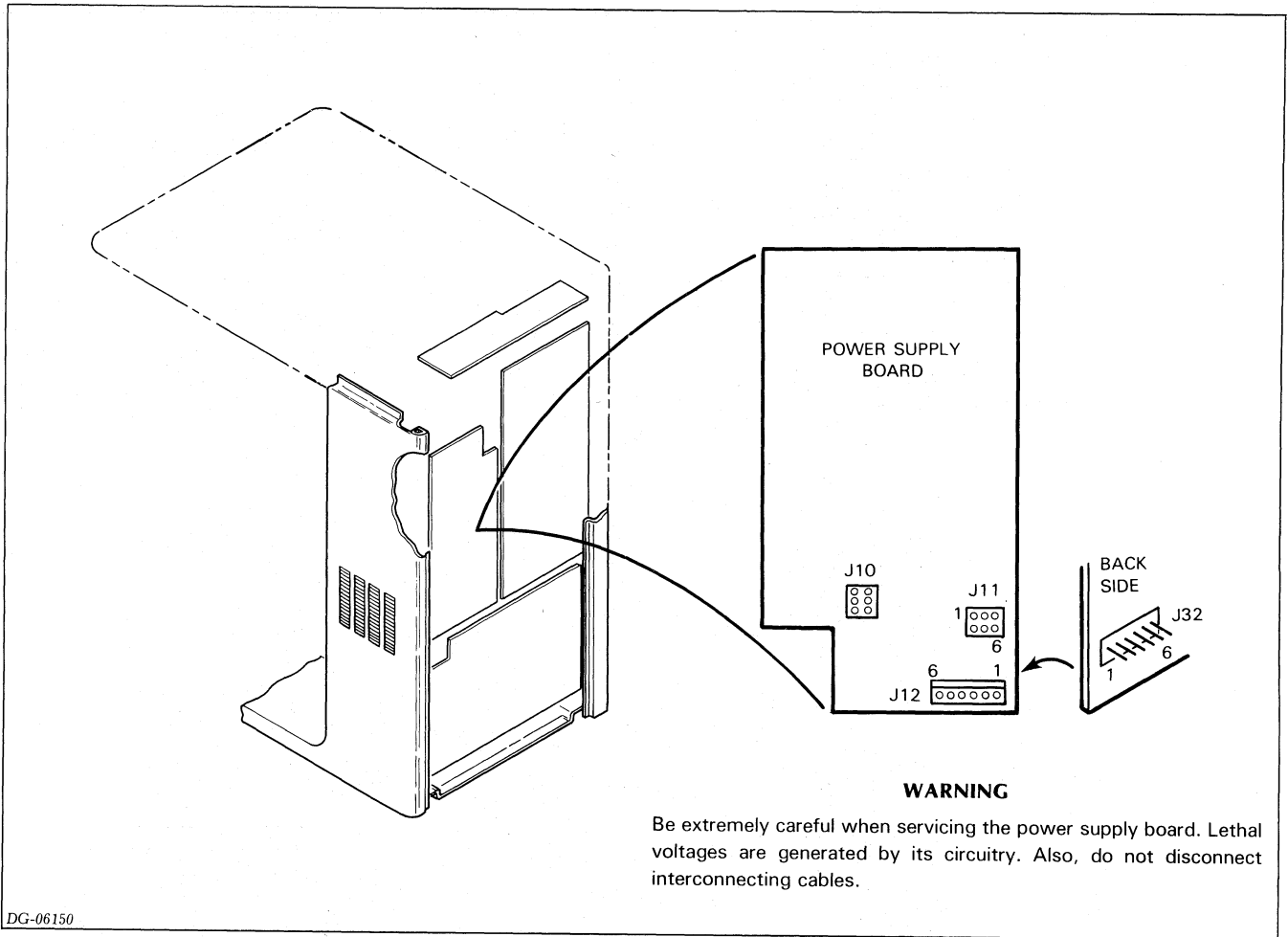

DG-06150

Figure 6.5 Connectors on Power Supply Boards

Pin	Voltage	Min.	Max.
1	-12 VDC	-12.4	-11.6
2	-5 VDC	-5.2	-4.8
3	Power OK	+4.8	---
4	Ground	---	---
5	+5.0 VDC	+5.0	+5.1
6	+14 VDC	+13.0	+15.0

Table 6.5 Connector J12 - To Main Control Board

Pin	Voltage	Min.	Max
1	-12 VDC	-12.4	-11.6
2	-5 VDC	-5.2	-4.8
3	Power OK	+4.8	---
4	No Connection	---	---
5	+5 VDC	+5.0	+5.1
6	+14 VDC	+13.0	+15.0

Table 6.6 Connector J32 - To Options Board, TP2 Printers only

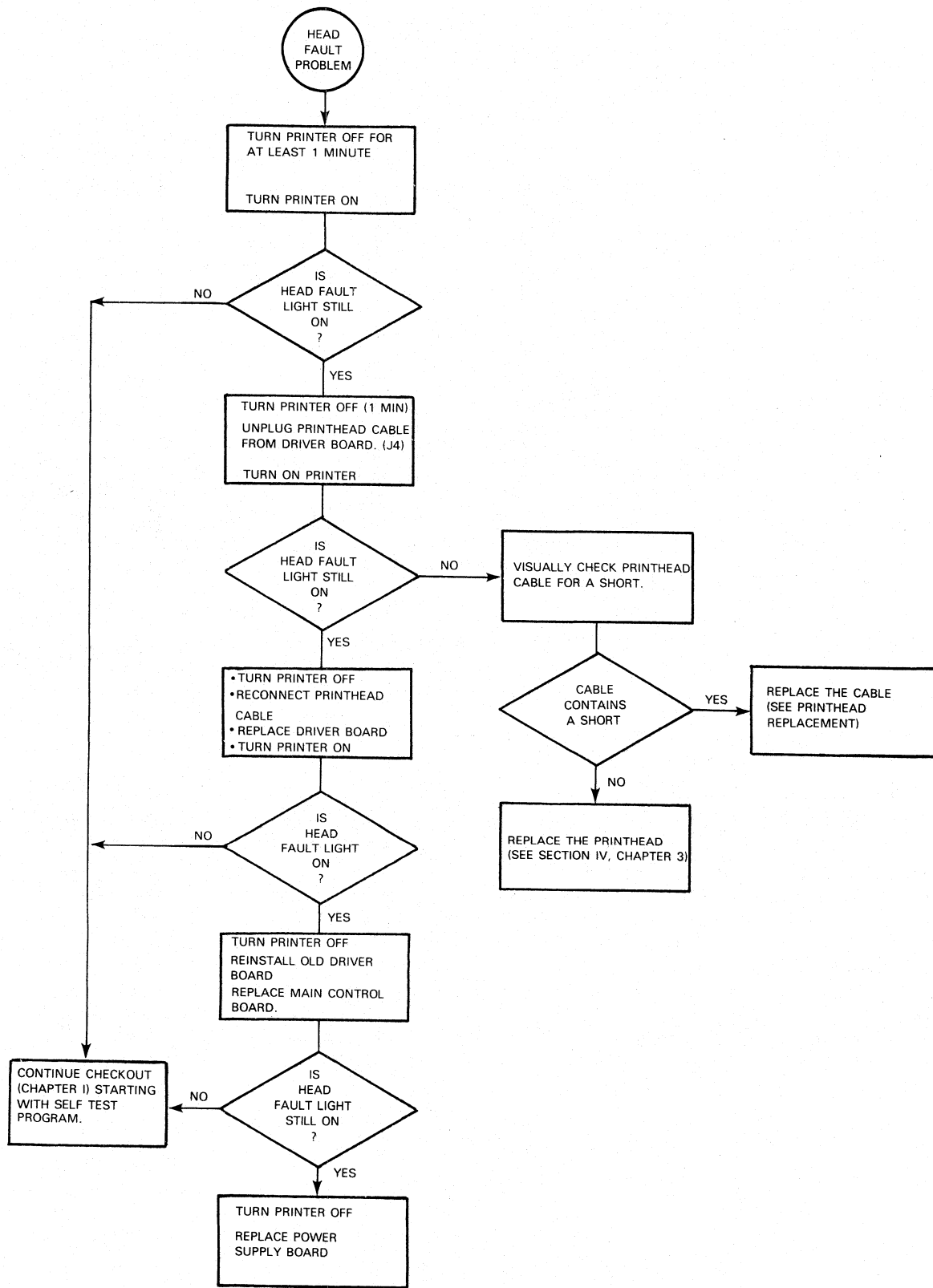

DG-06152

Figure 6.6 Flowchart for Head Fault Checkout

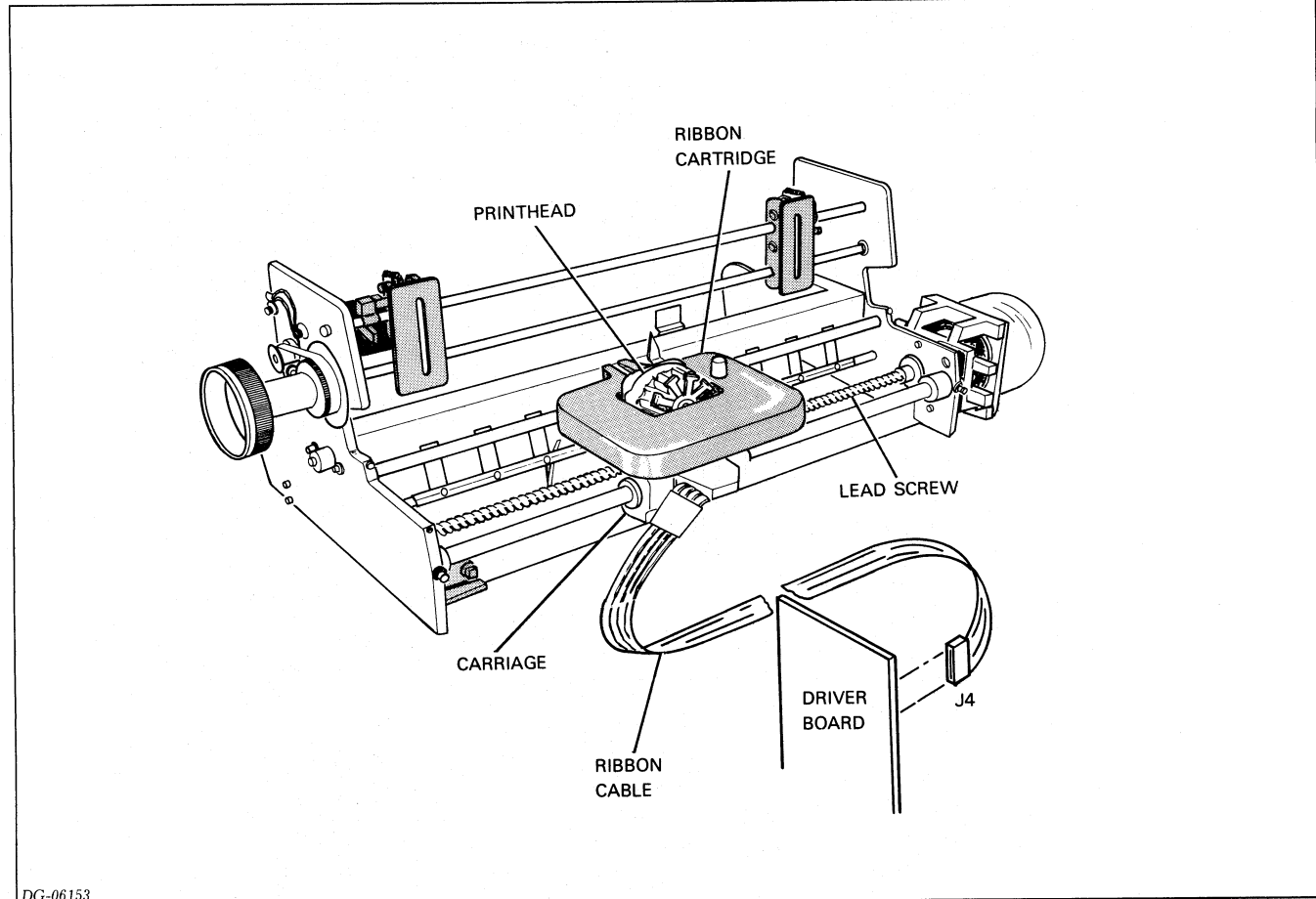

DG-06153

Figure 6.7 Printhead and Carriage Assembly



Chapter 7

SELF-TEST FEATURE

Introduction

The self-test feature allows you to test the printing capabilities of the printer while it is offline. Placing the printer in self-test mode causes the printer to print a continuously rotating character pattern in either normal or compressed format. By visually inspecting the printout, you can verify that a printer is operating correctly. Since the characters are generated internally, self test does not require an external device to generate the codes. However, this also means that the self-test feature does not test a printer's communications interface or the cabling to the controller.

Operating Procedure

First, load the printer with paper at least 14.5 inches wide.

To enter self test mode:

1. Place the printer offline.
2. Put the 6/8 LPI, NORM/COMP, and STD/ALT CHAR SET switches in positions that select the characteristics you wish to test.
3. Momentarily press the SELF TEST / ESC DISABLE Switch towards SELF TEST.
4. Switch the printer online.

To get out of self test mode press the MST RST (master reset) pushbutton on the secondary control panel.

It is a good idea to check out all the different modes of operation. If a printer is equipped with the compressed print format, run the self-test feature in normal mode and in compressed mode. If an alternate character generator is present, run the self-test feature at least once while the alternate character set is selected. You may also check the operation of the paper feed mechanism by running the self-test feature twice, once at 6 lines per inch vertical spacing and once at 8 lines per inch vertical spacing.

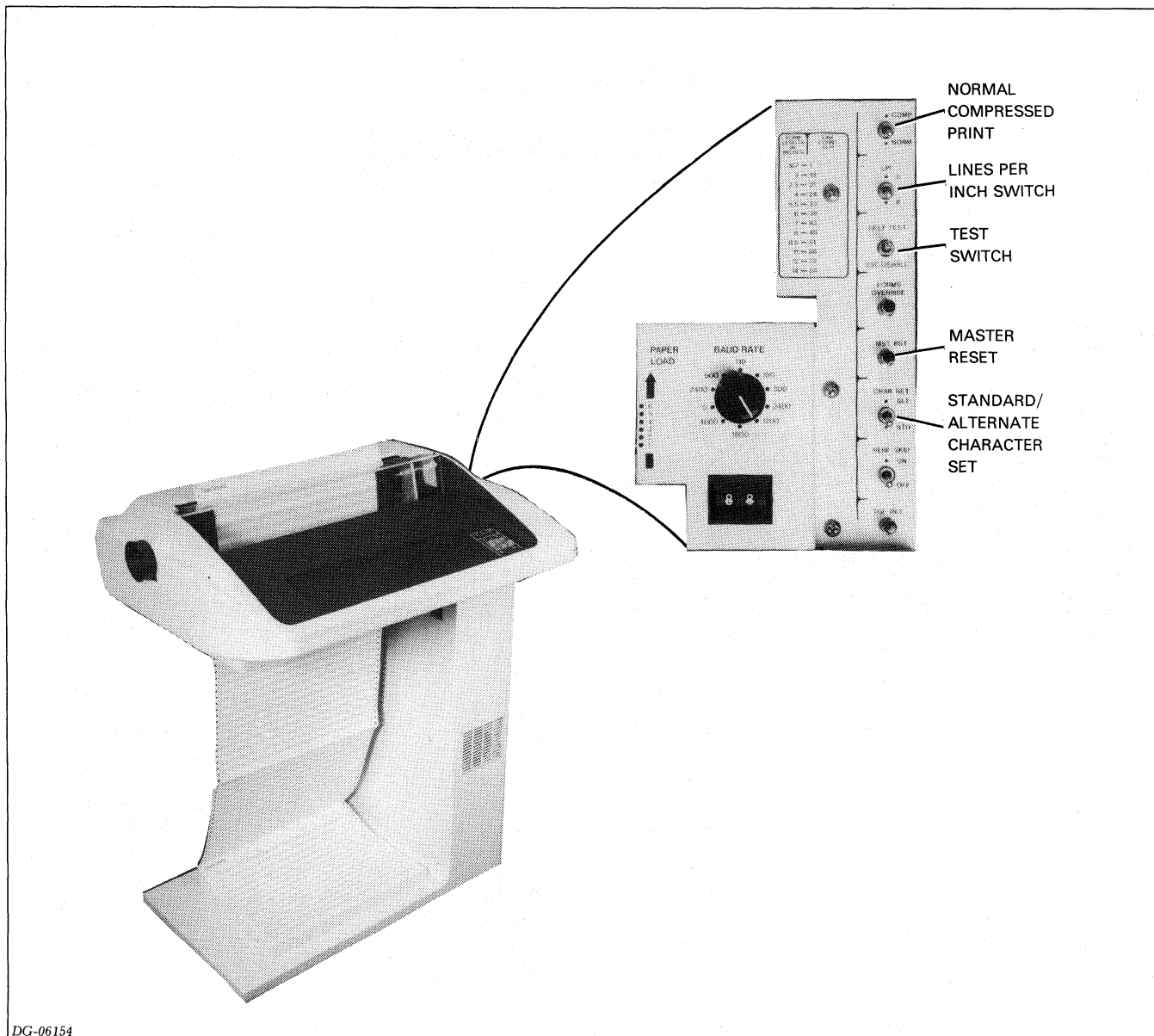

DG-06154

Figure 7.1 Secondary Control Panel

What to Look for in Self-Test Mode

After entering self-test mode the printer should start printing all of a character set's printing characters. Printing characters begin with the space character (40 octal) and end with the tilde character (176 octal). Printing should be bidirectional and the sequence should repeat indefinitely until the MST RST (master reset) switch is depressed. If necessary, you can compare printed characters with their proper formats (see Appendix B, **DASHER LP2 and TP2 Printers, User's Manual** (DGC No. 014-000094).

In particular, look for:

- - Even margins from line to line
- - Proper column alignment
- - Consistent intercharacter spacing
- - Light or smudged printing
- - Consistent paper feed spacing

```
!"#$%&'()*+,-./0123456789:;<=>?@ABCDEFGHIJKLMN OPQRSTUVWXYZE\J^_`abc  
"#$%&'()*+,-./0123456789:;<=>?@ABCDEFGHIJKLMN OPQRSTUVWXYZE\J^_`abcc  
#$%&'()*+,-./0123456789:;<=>?@ABCDEFGHIJKLMN OPQRSTUVWXYZE\J^_`abcde  
%&'()*+,-./0123456789:;<=>?@ABCDEFGHIJKLMN OPQRSTUVWXYZE\J^_`abcdef  
&'()*+,-./0123456789:;<=>?@ABCDEFGHIJKLMN OPQRSTUVWXYZE\J^_`abcdefg  
'()*+,-./0123456789:;<=>?@ABCDEFGHIJKLMN OPQRSTUVWXYZE\J^_`abcdefghi  
()*+,-./0123456789:;<=>?@ABCDEFGHIJKLMN OPQRSTUVWXYZE\J^_`abcdefghijk  
)*+,-./0123456789:;<=>?@ABCDEFGHIJKLMN OPQRSTUVWXYZE\J^_`abcdefghijk  
*+,-./0123456789:;<=>?@ABCDEFGHIJKLMN OPQRSTUVWXYZE\J^_`abcdefghijk  
+,-./0123456789:;<=>?@ABCDEFGHIJKLMN OPQRSTUVWXYZE\J^_`abcdefghijk  
, -./0123456789:;<=>?@ABCDEFGHIJKLMN OPQRSTUVWXYZE\J^_`abcdefghijklm  
-./0123456789:;<=>?@ABCDEFGHIJKLMN OPQRSTUVWXYZE\J^_`abcdefghijklmnc
```

DG-06402

Figure 7.2 Self-test printout

If You Find a Problem

If a failure causes the printer to completely stop printing, go to Chapter 6 to determine the cause. If any ongoing problems are observed (i.e., problems observed while the printer continues some sort of motion), go to Chapter 10 to determine probable causes.



Chapter 8

RELIABILITY PROGRAM

Introduction

The Reliability Program allows you to perform a complete checkout of a DASHER LP2 or TP2 printer subsystem. The program systematically exercises the printer's various print modes and its response to escape sequences and control codes. In addition to the standard tests, three optional tests are available. They include a keyboard test for TP2 printers, a burn-in test which prints about one page an hour, and a test allowing you to enter a message which will be printed continuously.

Program Information

Program Name: LP2REL.SR
 Rev: 00 9/1/78
 Text File: 097001114-00
 Listing: 096001114-01
 Program Starting Address: 200 (octal)

Program supplied on:

F. S. DTOS on Mag. Tape: 074000031-05D
 F. S. Interim Cassette #4: 005009248-01
 Peripherals DTOS Mag. Tape: 075000069-05D

Hardware Requirements

You must have a microNOVA, NOVA, or ECLIPSE computer equipped with 4K of memory (CS/40, CS/60). LP2 printers must be connected to a line printer controller. TP2 printers must be connected to a single line asynchronous controller.

Operating Procedure

Before running the reliability program, load the printer with single form paper at least 14.5 inches wide. Upon starting the program it will state:

ENTER INPUT DEVICE CODE, IF KEYBOARD PRESENT (CR) If you are testing a KSR TP2 printer and you want the keyboard test to run on the first pass of the program, then enter a device code followed by a **CR** (carriage return) or an **LF** (line feed). If you do not want the test to run or you are testing a receive only (RO) printer, just give a **CR** or an **LF**. The allowable answers are:

- **<CR>** - no keyboard present or no keyboard test desired
- **10 <CR>** - for the primary console (on a 4010 controller)
- **50 <CR>** - for a secondary console (on a 4010 controller)

Following an answer to this question the program will state:

ENTER OUTPUT DEVICE CODE (CR) Enter the device code followed by a **CR** or an **LF**. Table 8.1 lists the possible device codes along with the various system configurations.

Printer	System	Device Code
LP2	NOVA, ECLIPSE	17-primary printer 57-secondary printer
	CS/40, CS/60	17C-primary printer 57C-secondary printer
TP2	NOVA, ECLIPSE CS/40, CS/60	11-primary console 51-secondary console

Table 8.1 Device Codes

Following the answer to the second question, tests one through fifteen begin running. A pass count is printed on the master console each time all the tests are passed. The Reliability Program uses the standard switch register format and diagnostic control characters as outlined in the *DTOS Summary* (DGC No. 015-000082).

Selecting Individual Tests

Individual tests may be run by setting bit 15 of the software switch register to 1, or by typing an **F** on the master console. After the **F** is echoed, the following direction appears:

ENTER TEST #

Select the desired test by typing in its test number followed by a **<CR>**. To terminate a test selected in this manner, type another **F**. Wait until the regular test sequence resumes before selecting another individual test.

Test Summaries

Test #: 1

Test checks: That a program interrupt is generated by the device controller after it transfers a character to the printer.

Restrictions: Runs only on the first pass of the diagnostic. This is the only test that can detect an error and return a message to the system master console.

What to look for: The test has been passed if no message is returned to the master console (unless bit 2 of "SWREG" is a 1, aborting printouts). If an error results, the interrupt did not occur (the AC's printed out have no meaning). In this case, check the interrupt priority chain to make sure the interrupt request can reach the processor.

Test #: 2

Test checks: Normal and elongated printing.

Restrictions: None

What to look for: On the first pass, the test prints a line of 132 normal E's followed by a line of 66 elongated E's. On subsequent passes, it prints 60 alternating lines of normal and elongated E's. Margins should line up. The first column of each elongated E and every other normal E should line up as illustrated in Figure 8.1.

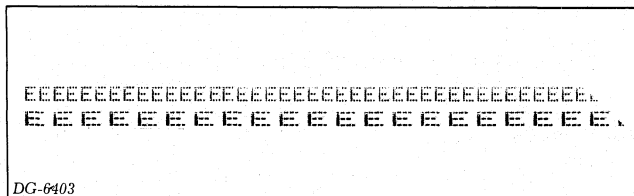

Figure 8.1 Partial printout, test #2

Test #: 3

Test checks: Normal printing, interline and character spacing, and the printing of variable length lines.

Restrictions: None

What to look for: Prints 132 lines of 1 to 132 M's in the shape of a right triangle. Printing should be bi-directional, and intercharacter and interline spacing should be consistent. Note that there should be a low to high print speed transition after the 7th line.

Test #: 4

Test checks: The four print modes: normal, compressed, compressed elongated, and regular elongated.

Restrictions: DASHER LP2 and TP2 printers without the compressed print option will print two regular print blocks and two regular elongated print blocks.

What to look for: Prints a rotating alphabetical pattern in normal, compressed, compressed elongated and regular elongated modes. All patterns consist of each upper case and lower case alphabetical character in order (i.e., AaBbCcDd...).

The regular and compressed print patterns consist of 55 characters per line by 60 lines. These blocks should be located 27 spaces from the left margin.

The compressed elongated print and the regular elongated print patterns consist of 39 characters per line by 60 lines. These blocks should also be located 27 spaces from the left margin.

Test #: 5

Test checks: The escape sequence which sets a horizontal tab at current printhead position.

Restrictions: This test cannot run on systems using a Data Channel Line Printer Controller (005008096) to drive a DASHER LP2 Printer.

NOTE: On a TP2 configured for 7 data bits, the test will appear to fail due to a checksum error in loading Test number 6.

What to look for: The test:

- Prints the message 'PRINT AND SET A TAB USING ESC 1';
- Sets a horizontal tab at the present printhead position (after the '1');
- Issues a linefeed, a horizontal tab, and prints the message 'I SHOULD BE PRINTING FROM PRINT POS 32 OVER' 60 times.

All 60 lines reading "I SHOULD BE PRINTING FROM PRINT POS 32 OVER" should be doing just that.

Test #: 6

Test checks: The escape sequences which load, select, and deselect a down-line-loaded character set.

Restrictions: This test is not run on systems using the Data Channel Line Printer Controller (005008096) to drive a DASHER LP2 Printer or on CS/40 or CS/60 systems with an LP2 Printer. It also will not run on TP2 printers interfaced to systems using serial interfaces transferring only 7 data bits. The interface must be able to transmit 8 data bits per character to work.

What to look for: Down line loads a three-character character set and, on the first pass of the diagnostic, prints one line using the three characters. On subsequent passes of the diagnostic, the test prints 60 lines. Each line consists of "DL_" repeated 27 times. Make sure the characters are loaded properly. If the fault light comes on, it indicates that a checksum error was encountered. This usually means the printer received some bad data.

Test #: 7

RELIABILITY PROGRAM

Test checks: The escape sequences that set and clear multiple vertical tabs.

Restrictions: Test does not run on systems using a Data Channel Line Printer Controller (005008096) to drive a DASHER LP2 Printer.

What to look for: Sets 9 vertical tabs, each 6 lines apart, with the sequence ESC F # # ... Null and issues 9 Vertical tab control codes printing the message "VERTICAL TAB TEST" each time. These should be evenly spaced 6 lines apart, and all should be indented 6 print positions from the left margin.

Test #: 10

Test checks: The clear horizontal tab from current printhead position escape sequence.

Restrictions: Test does not run on systems using a Data Channel Line Printer (005008096) to drive a DASHER LP2 Printer.

What to look for: Sets and clears a horizontal tab from the 32nd column position using the ESC 1 and ESC 2 sequences. The following descriptive printout message appears 15 times: PRINT AND SET A TAB USING ESC 1
PRINT AND CLR A TAB USING ESC 2
I SHOULD BE PRINTING FROM PRINT POS 1 OVER

Each line of the message should print starting one space from the left margin.

Test #: 11

Test checks: The set vertical tab at current line position and clear tab from current line position escape sequences.

Restrictions: None

What to look for: The test first sets 8 vertical tabs on the lines where it prints "SET A VERT TAB". These lines should be 6 lines apart. Next it issues 8 vertical tab control codes printing "VERTICAL TAB TEST". Then it clears each of the tabs. Finally it ensures all vertical tabs are cleared by issuing 8 vertical tab control codes and printing "VERTICAL TAB TEST"; this time the 8 messages should appear together since no tabs are set.

Test #: 12

Test checks: the proper operation of the start underscore and the stop underscore escape sequences in all four print modes.

Restrictions: Printers without the compressed print feature will print two regular lines and two elongated lines.

What to look for: The test should print:
REGULAR PRINT UNDERSCORED
COMPRESSED PRINT UNDERSCORED
COMPRESSED ELONGATED PRINT UNDERSCORED
ELONGATED PRINT UNDERSCORED

The word "UNDERSCORED" should be underlined each time. This pattern is repeated 8 times. Make sure all print modes are reproduced properly.

Test #: 13

Test checks: Plotting mode.

Restrictions: None

What to look for: On first pass of diagnostic, the word "PLOTED" is alternately formed (and misspelled) in a reverse block and a normal block 9 times, all on one line. On subsequent passes of the diagnostic, this line is repeated 60 times. Plotting takes place at slow speed from left to right only. On subsequent passes of the diagnostic, there should be no interline spacing.

Test #: 14

Test checks: Horizontal tabs and the interrupt system in the printer's internal microprocessor.

Restrictions: Test does not run on CS/40 or CS/60 systems.

What to look for: On first pass of the diagnostic, test should print one line of equally spaced X's. On subsequent passes, 66 lines of X's are printed. Check for equal intercharacter spacing. If a character space is left in any line, the test failed. Check the carriage positioning transducer adjustments.

Test #: 15

Test checks: Correct operation of firmware that determines printhead direction.

Restrictions: None

What to look for:

>>>> (printhead should be moving from left to right).
<<<< (printhead should be moving from right to left).

Test #: 16

Test checks: Alternate character set option.

Test #: 17

Test checks: Operation of keyboard on DASHER TP2 Terminals.

Restrictions: If a keyboard device code is entered after the first start-up question, this test is run on the first pass of the diagnostic. It may also be selected and looped on. Type two periods (..) to exit test.

What to look for: The octal value of the character generated by striking a key on the printer's keyboard is echoed on the system's master console (see Appendix A for the codes generated by the various keys). Exit the test by typing two consecutive periods on the keyboard under test.

Test #: 20

Test checks: Allows the operator to define a message to be printed on the printer.

Restrictions: Does not run unless selected. Message is entered on the master console. A CONTROL Z terminates input and starts the test.

What to look for: Message should be printed as entered on the master console. The message will be repeated until an **F** is typed on the system console. You can enter control codes and escape sequences if the master console allows the generation of these codes.

Test #: 21

Test checks: This is a burn-in test. Prints a little over a page an hour (a good long-term test).

Restrictions: Does not run unless selected.

What to look for: This test prints 132-character lines with the lower and upper case alphabets. It prints two characters at a time at alternating edges of the paper until a line is completely filled. Look for consistent intercharacter spacing and good print quality.

Chapter 9

TERMINAL TESTER

Introduction

This chapter tells you how to test a printer's various print modes and escape sequences with a DASHER Terminal Tester. It is assumed that you are familiar with the basic set-up and operation of a Terminal Tester. If not, see *How to Use and Service the DASHER Terminal Tester* (DGC No. 015-000087).

The Terminal Tester can test a DASHER LP2 or TP2 printer in the following ways:

1. It can transmit single printing codes or a rotating pattern of codes with a selected number of characters per line.
2. It can transmit control codes and escape sequences to check the printer's special functions (see Appendix B).
3. It can store up to 40 characters received from a TP2 printer's keyboard or it can echo received characters, transmitting them back to the printer.

When to Use the Tester

The DASHER Terminal Tester may be used to test the online operation of an LP2 or TP2 printer if a CPU and controller are not available to run the Reliability Program or if running the Reliability Program would tie up a system which otherwise could be productive. Moreover, since the Tester is a *known data source*, it will help you decide when a problem does not come from the printer but from the external cabling, the controller, the communications network, and/or software. Since the tester does not test the external cable or controller, it is a good idea to run the Reliability Program as a final test.

Test Procedures

Ten tests are outlined below. They test the four print modes (two modes for printers without compressed print) and the various escape sequences. Each test consists of one or more procedures to be performed with the aid of the tester. In each case, we explain the purpose of the test and tell you which codes to transmit.

Test Selection

Always perform Test #1. It is not necessary to perform Tests 2 through 10 unless you wish to check specific escape sequences.

If a Test Fails

If a test appears to fail, try issuing the codes to the printer a second time. If the test does not produce any response, the printer stops printing, or the FAULT light comes on, go to Chapter 6; otherwise, go to Chapter 10.

Notes on Tests

1. All numeric values are in octal.
2. The tester automatically inserts a line feed and carriage return code pair at an interval determined by the Select Line Length switches. As a result, we direct you to reset the tester and transmit three line feed codes at the beginning of each test. The first two codes transmitted will actually be these line feed and carriage return codes. The third code transmitted will be the line feed code you selected in the Character Selected switches. Since your Select Line Length switches will be set for 80 characters per line, you can transmit 80 codes before another carriage return-line feed pair are inserted. If you do not reset the tester, you will not know when the code pair is inserted in the transmit data stream.

Test #1

Rotating Character Pattern Test (all 4 print modes)

Aim: To print all characters from 40 - 176₈ in normal mode.

Transmit: Continuous character pattern with a line length of 80 (switches 64 and 16 up).

Reset the tester.

Aim: To print all characters from 40 - 176₈ in compressed mode.

Transmit: 012 (3 times), 033, 076, and a continuous character pattern with a line length of 80.

Reset the tester.

Aim: To print all characters from 40 - 176₈ in compressed elongated mode.

Transmit: 012 (3 times), 033, 074, and a continuous character pattern with a line length of 40 (switches 32 and 8 up).

Reset the tester.

Aim: To print all characters from 40 - 176_g in normal elongated mode.

Transmit: 012 (3 times), 033, 077, and a continuous character pattern with a line length of 40.

Reset the tester and the printer. Set the Select Line Length Switches on the tester so that the 64 and 16 switches are up.

Test #2

Bell (Audible Tone) Test

Aim: To sound the audible tone.

Transmit: 012 (3 times) and 007.

Test #3

Backspace Test

Aim: To return the printhead to the left margin, move it five spaces to the right, and move it back five spaces to the left margin.

Transmit: 012 (3 times), 040 (5 times), 010 (5 times).

Test #4

Form Feed Test

Set the Line Count Switches on the printer's secondary control panel to 10. Press MST RST on the printer

Transmit: 014 (4 times).

Aim: To feed 10 lines of paper each time an 014 is transmitted.

Set the Line Count Switches on the printer to 20. Press MST RST on the printer.

Transmit: 014 (4 times).

Aim: To feed 20 lines of paper (twice as much as before) each time an 014 is transmitted.

Reset the tester.

Test #5

Horizontal Tab Test

Aim: To print four A's 10 spaces from the left margin followed by four A's at the left margin.

Transmit: 012 (3 times), 040 (10 times), 033, 061, 012, 011, 101 (4 times); 012, 040 (10 times), 033, 062, 012, 011, 101 (4 times).

Aim: To print four A's at the 40th column; four B's at the 80th column; and four C's at the 120th column followed by a line of four A's, four B's, and four C's at the left-hand margin.

Transmit: 033, 105, 040, 100, 140, 000, 012, 011, 101 (4 times), 011, 102 (4 times), 011, 103 (4 times), 012, 033, 105, 000, 011, 101 (4 times), 011, 102 (4 times), 011, and 103 (4 times).

Reset the printer and tester.

Test #6

Vertical Tab Test

(Requires Automatic Form Feed Option)

Place the printhead at the top of the form and reset the printer.

Aim: To print four X's at the top of a form, four Y's at the top of the next form followed by four Y's 10 lines down.

Transmit: 012 (11 times), 033, 065, 014, 012, 033, 065, 014, 130 (4 times), 013, 033, 066, 131, (4 times), 014, 130 (4 times), 013, 131, (4 times).

Reset the tester.

Aim: To print four A's on the 1st line, four B's on the 20th line, and four C's on the 40th line; followed by four A's, B's, and C's overprinted on the first line of the next form.

Transmit: 012 (3 times), 033, 106, 020, 040, 000, 101 (4 times), 013, 102 (4 times), 013, 103 (4 times), 014, 033, 106, 000, 101 (4 times), 013, 102 (4 times), 013, and 103 (4 times).

Reset the printer

Test #7

Underscore Test

Aim: To print "DDDDGGGGCCCC" with all four G's underscored.

Transmit: 104 (4 times), 033, 141, 107 (4 times), 033, 142, and 103 (4 times).

Test #8

Reset Test

Aim: To initialize the printer (see Chapter 6) (printhead should move to the left-hand margin and the present line should become the top of form).

Transmit: 012 (3 times), 033, 143

Reset the tester.

TERMINAL TESTER



Test #9
Plotting Test

Aim: To plot a square at the left margin.

Transmit: 012 (3 times), 033, 144, 177, 100 (12 times), 177, 033, 145, 012, 033, 144, 177, 001 (12 times), 177, 033, 145, and 012.

Reset the tester.

Test #10

Down-Line-Loaded Character Set Test

Aim: To down-line-load a character set consisting of one character, the letter B. If the FAULT light goes on, a checksum error may have been detected (you may have entered a wrong code).

Transmit: The following loads the character B: 012 (3 times), 033, 131, 000, 020, 010, 000 (3 times), 001, 004, 000, 370, 001, 004, 000, 040, 001, 004, 000, 040, 000, 330, 341.

Aim: To select the character set and print a B (B is printed in place of the space character normally printed when a printer receives 040 g).

Transmit: The following selects the down-line-loaded character set: 033, 116, 003, 000. Place the tester in continuous single character mode and transmit 040.



Chapter 10

TEST PROBLEMS

Introduction

This chapter helps you determine the failing field replaceable unit by suggesting probable causes and corrective actions for various symptoms observed while the printer is printing. If the printer does not respond at all or its indicator lights show a fault condition (see Chapter 5) go to the troubleshooting procedures outlined in Chapter 6. Otherwise, look through the column marked "symptoms" in the troubleshooting table and find the symptom which most closely reflects the observed problem. For quick reference, a summary of the various symptoms appears below in the same order that the symptoms appear in the table:

- Margins do not line up, sloppy character spacing
- Dark smudgy print
- Light printing (or no printing, but printhead fires)
- No printing (printhead wires not firing)
- Print wires are misfiring
- Prints '■'
- Prints incorrect characters
- Improper paper feed spacing
- Carriage moves in jerking motions or carriage overruns the margins
- Control codes or escape sequences do not work correctly

Once you identify a symptom, check the items indicated under "probable causes." Check the various causes in order, when possible (i.e., a,b,c,...). If you must replace a part or perform an adjustment, go to the appropriate chapter in Part IV to find the procedure.

Symptom	Probable Cause	Corrective Action
Margins do not line up from line to line, sloppy character positioning, or uneven character spacing.	<ul style="list-style-type: none"> a. Carriage position transducers out of adjustment. b. Leadscrew and nut are worn. c. The couplings between the leadscrew and the carriage motor are loose. d. The carriage mechanism is binding or dragging. e. Ribbon cartridge is binding or jammed. 	<ul style="list-style-type: none"> a. Perform Carriage Sector Disc(s) Timing Adjustment: Parts I & II b. Perform Antibacklash Nut and Leadscrew Replacement. c. Tighten clamp screws and/or replace the plastic coupling adaptor. d. Perform the Carriage Bearing Cleaning and Adjustment Procedure. <p>Perform the Ribbon Cartridge Drive Cable Adjustment.</p>
Dark smudgy print.	<ul style="list-style-type: none"> e. Ribbon cartridge is binding or jammed. a. Printhead is too close to platen. 	<ul style="list-style-type: none"> e. Replace the Ribbon Cartridge. a. Adjust the platen space lever. If this does not solve the problem, perform the Platen Alignment Procedure. <p>Replace the platen if it is bent or too worn to be adjusted properly.</p>
Light printing (or no printing) but the printhead is firing	<ul style="list-style-type: none"> a. The ribbon is worn. b. Printhead is too far from the platen. c. Ribbon mechanism is not advancing ribbon properly. d. Ribbon cartridge is binding. 	<ul style="list-style-type: none"> a. Replace the ribbon cartridge. b. Adjust the platen space lever. If this does not work, perform the Platen Alignment Adjustment. c. Perform the Ribbon Cartridge Drive Cable Adjustment. d. Replace the ribbon cartridge.
No printing (print- wires are not firing).	<ul style="list-style-type: none"> a. Cable from printhead to driver board is loose or disconnected. b. Faulty printhead. c. Faulty driver board. d. Faulty main control board. e. Faulty power supply (48 volt supply). 	<ul style="list-style-type: none"> a. Reconnect ribbon cable. b. Replace printhead. c. Replace driver board. d. Replace main control board. e. Replace power supply board.
Faulty printing (printwires are misfiring).	<ul style="list-style-type: none"> a. Printhead jewel is dirty, causing the printwires to jam. b. Faulty printhead winding. c. Faulty driver board. d. Faulty main control board. 	<ul style="list-style-type: none"> a. Clean printhead jewel as outlined in step 3 of the Preventive Maintenance Procedures (Part IV, Chapter 14). b. Replace printhead. c. Replace Driver Board. d. Replace Main Control Board.
Prints "■"	<ul style="list-style-type: none"> a. A parity error was detected upon receiving the character (TP2 printers). b. Standard/Alternate Character Set switch in wrong position. 	<ul style="list-style-type: none"> a. Make sure the parity selected by jumpers on the options board agrees with the controller. <p>Check the external cable for secure connections. Replace the options board (serial interface).</p> <ul style="list-style-type: none"> b. Place in correct position.

Table 10.1 Troubleshooting Table for Test Problems

TEST PROBLEMS

Symptom	Probable Cause	Corrective Action
Prints incorrect characters.	<ul style="list-style-type: none"> a. Printer is printing a down-line-loaded character set. b. Faulty character generator. 	<ul style="list-style-type: none"> a. Press MST RST (master reset) switch to clear. b. Replace character generator.
Improper paper feed spacing (Fault light comes on after a number of lines).	<ul style="list-style-type: none"> a. Paper feed transducer is out of adjustment. b. Incorrect platen to printhead spacing. Paper is being pinched between printhead and platen. c. Paper tension bar is too tight. d. Bad connection in cable from paper feed motor to J2. e. Faulty driver board. f. Faulty main control board. 	<ul style="list-style-type: none"> STANDARD: main cntrl. bd. ALTERNATE: options bd. a. Perform the Vertical Transducer Adjustment. b. Change spacing via the platen adjustment lever. If necessary, perform the Platen Alignment Adjustment. c. Perform the Paper Tension Bar Adjustment. d. Fix cable and/or connector. e. Replace driver board. f. Replace main control board.
Carriage moves in jerking motions	<ul style="list-style-type: none"> a. Carriage position transducers and/or code disc(s) are dirty. 	<ul style="list-style-type: none"> a. Clean position transducers and code disc(s) (see step 4 of the Preventive Maintenance Procedures, Section IV, Chapter 2).
Carriage overruns the margins and/or bangs into end-plates.	<ul style="list-style-type: none"> b. Carriage position transducers are out of adjustment. c. Carriage is binding. 	<ul style="list-style-type: none"> b. Perform the Carriage Sector Disc(s) Timing Adjustments: Parts I and II and the Print Transducer(s) Adjustment. c. Check to see that the following parts are not jamming: -ribbon cartridge -ribbon drive gearbox -carriage rail bearings
Control codes or escape sequences do not work correctly.	<ul style="list-style-type: none"> d. Cable connecting the carriage position transducers to the driver board is disconnected or bad. e. Transducer detect logic on driver board is bad. f. Transducer control logic on main control board is bad. g. Transducers are bad. a. Printer running from a Data Channel Line Printer controller or the Commercial System's controller (these controllers pass only 7-bit ASCII codes to the printer as well as intercept some control codes). (LP2 printers) b. Main control board is faulty (firmware ROMs are bad). 	<ul style="list-style-type: none"> d. Check cable (normal print cable goes to J9, compressed cable goes to J8). e. Replace the driver board. f. Replace main control board. g. Replace the transducers. a. Use a different line printer controller. b. Replace the main control board.

Table 10.1 Troubleshooting Table for Test Problems (Cont'd)



Part 3

Functional Overview



Chapter 11

ARCHITECTURE

DASHER LP2 and TP2 printers are controlled by a Data General 16-bit microprocessor. The microprocessor directs communication between a number of the printer's basic subsystems. These subsystems include:

- Memory
- Printhead and carriage assembly
- Paper feed assembly
- Control panels
- Keyboard and numeric pad
- Parallel interface or serial interface.

Information is transferred between these subsystems and the microprocessor along a bidirectional 16-line bus. Figure 11.1 illustrates how this bus connects the different portions of the printer.

The Microprocessor

The microprocessor's main function is to control the printer's various subsystems. The manner in which these subsystems are controlled is determined by the microprocessor's program.

Memory

The memory subsystem stores the microprocessor's program and variables, characters received from the computer, and special codes used by the microprocessor to fire the printhead.

A DASHER LP2 or TP2 printer has two types of memory: read-only memory and read/write (random-access) memory. Read-only memory stores the printer's control program and its contents remain unaltered when the printer is turned off. Read/write memory stores variables (used by the control program) and incoming characters; however, it loses these contents when the printer is turned off.

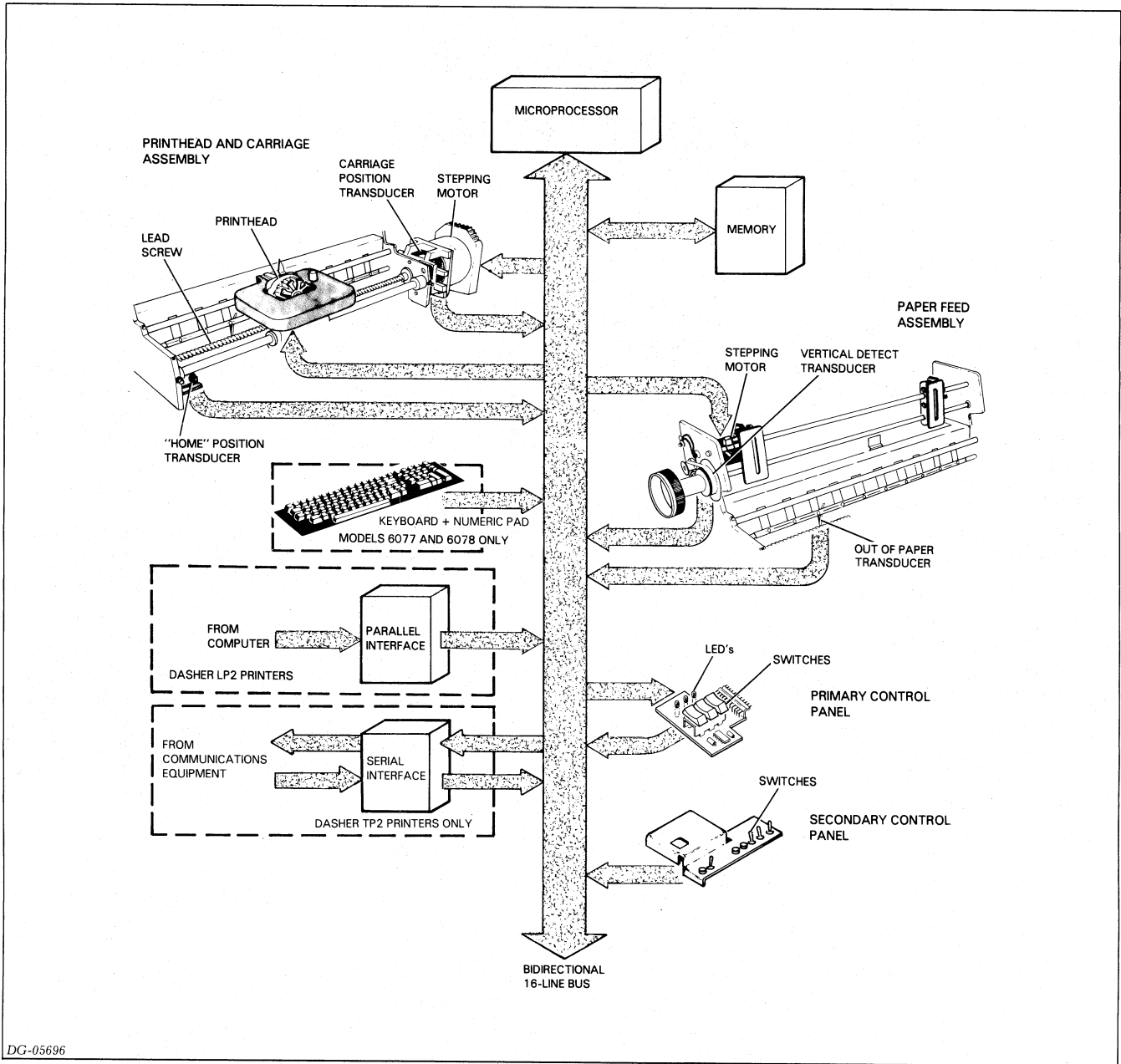

DG-05696

Figure 11.1 Bidirectional 16-Line Bus and Subsystems

A third storage device, the character generator, is really a read-only memory which contains special codes used by the microprocessor to fire the printhead. These codes, called firing codes, are nine bits long. The character generator contains the firing codes necessary to print all the characters in a particular character set.

Printhead and Carriage Assembly

The printhead and carriage assembly is the mechanism which prints characters. Figure 11.2 illustrates the various components of this subsystem.

The Printhead

The printhead forms a character in seven segments as it moves across the paper. Each segment is formed by firing a subset of the 9 printhead wires. These wires force the ribbon against the paper forming a 7 by 9 dot matrix character. The microprocessor fires these print wires by obtaining a 9-bit code from the character generator and transmitting that code to the printhead. Figure 11.3 shows how a character is formed during a left to right print sequence.

Since printing is bidirectional, a character may also be formed by starting with its right column. In this case, the microprocessor issues the firing codes in reverse order.

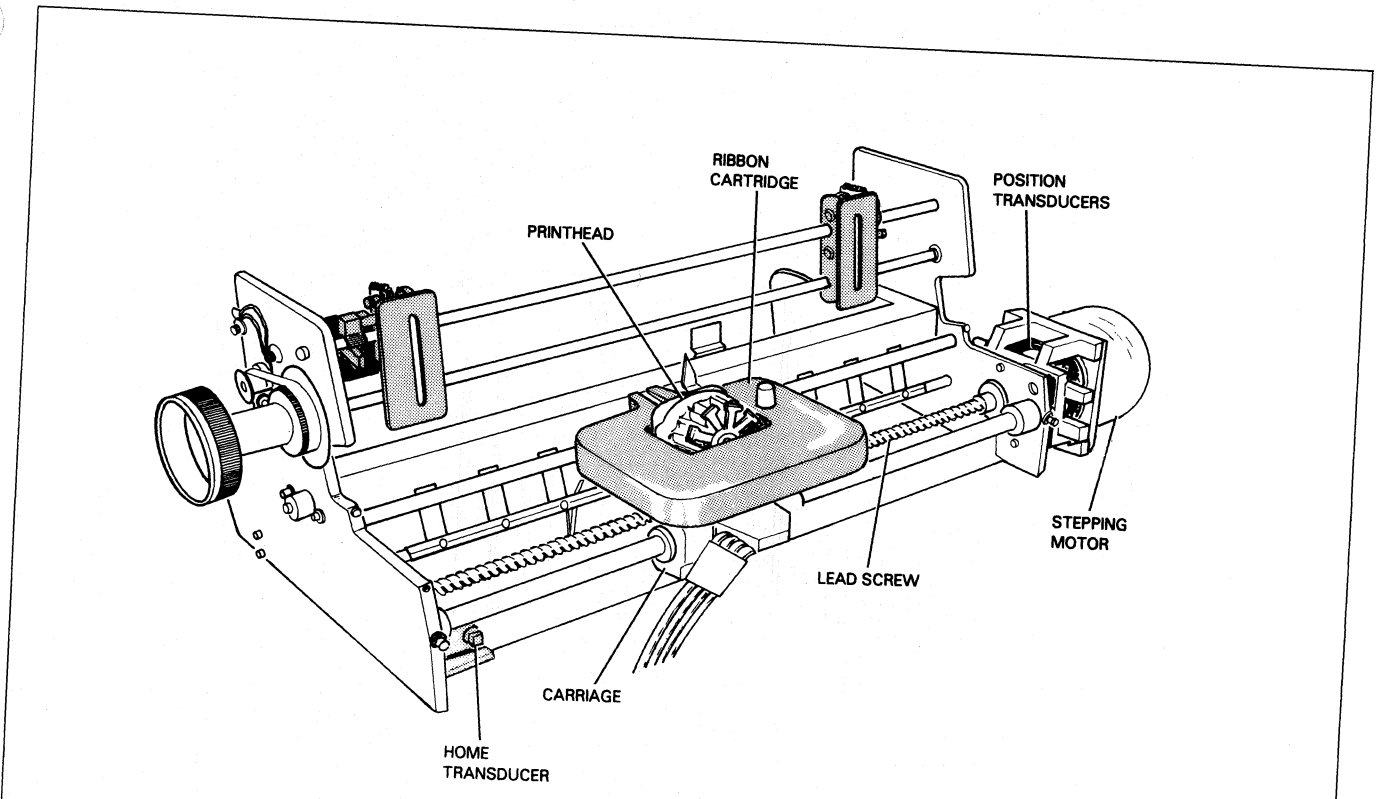

DG-04769

Figure 11.2 Printhead and Carriage Assembly

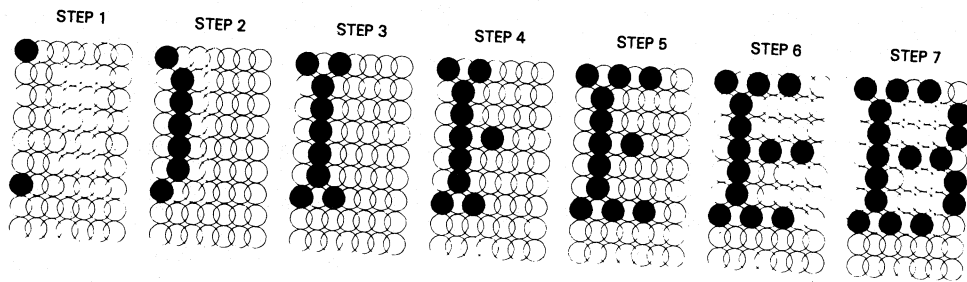

DG-04744

Figure 11.3 Forming a Character

The Carriage

The microprocessor controls the horizontal motion of the printhead by issuing commands to the drive circuitry of the carriage mechanism. This mechanism consists of a stepping motor and lead screw assembly (to which the printhead carriage is attached). When the microprocessor steps this motor (tells it to rotate a fixed amount), the lead screw turns, moving the printhead a fixed distance. Since the stepping motor may be stepped clockwise or counter-clockwise, the printhead may be moved either right or left.

Position Transducers

The microprocessor determines when the print wires should be fired by monitoring the printhead position transducer. This transducer locates the exact printhead firing position for each of the seven columns which form a character.

Another transducer informs the microprocessor when the printhead has reached the left-hand margin (home position). This transducer is used to initialize the printhead's horizontal alignment.

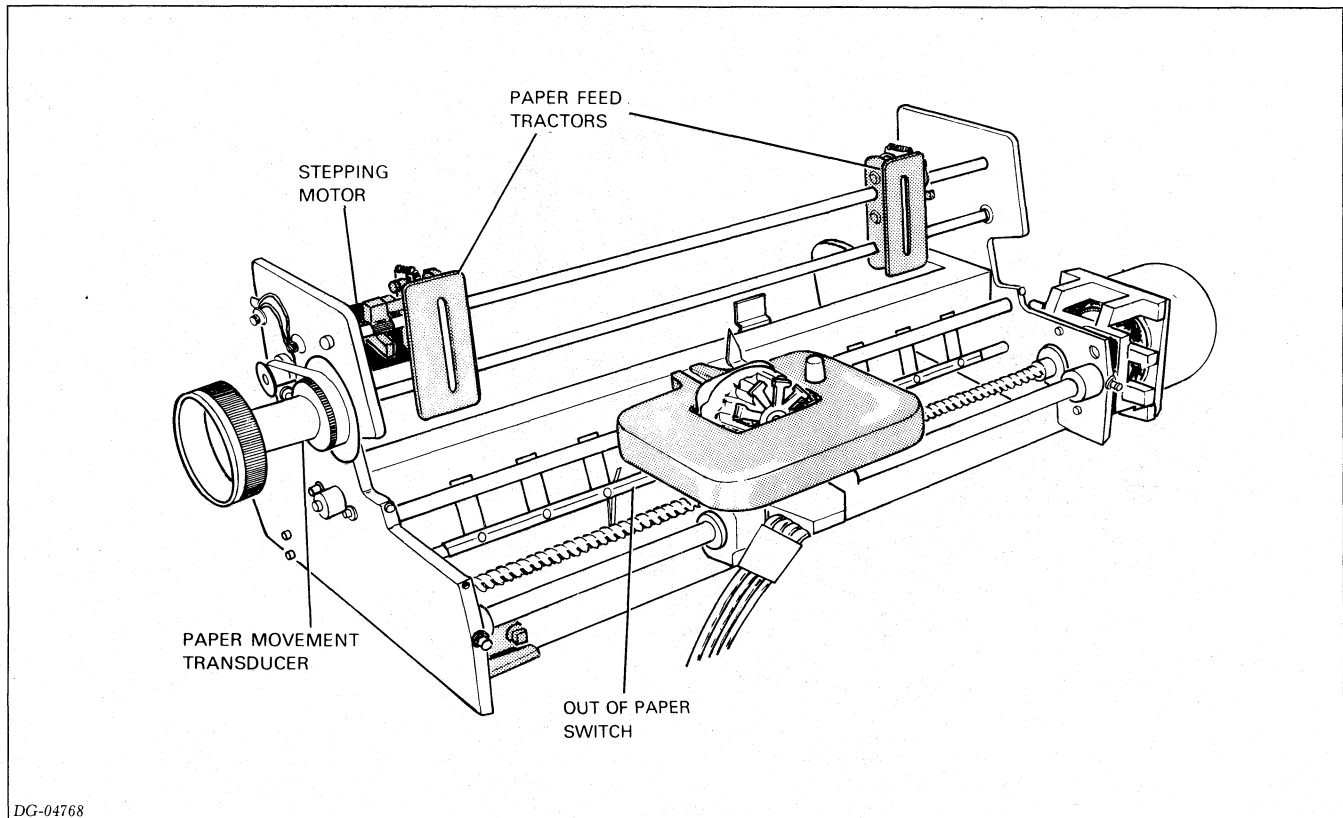

Figure 11.4 Paper Feed Assembly

Paper Feed Assembly

The paper feed assembly controls the vertical movement of paper past the printhead. Like the carriage mechanism, the paper feed assembly uses a stepping motor. This motor turns the tractors which move the paper by the printhead. The microprocessor directly controls how much paper is fed through the printer by stepping this motor a selected number of times. In fact, the difference between selecting 6 lines/inch or 8 lines/inch spacing is reflected in the number of steps the microprocessor issues to the stepping motor for a line feed.

Sensing Paper Movement

A transducer, like the head position transducer, notifies the microprocessor each time it senses paper movement. If the transducer detects that the paper feed motor has taken a different number of steps than were issued by the microprocessor, a paper fault is generated, indicating a problem in the paper feed assembly.

A switch informs the microprocessor when paper runs out. If this occurs, the microprocessor generates a paper fault.

The Control Panels

There are two control panels which you may use to control a printer. The primary control panel contains a number of lights and switches used to display status information and control commonly used functions. The secondary control panel contains switches which configure the printer and

select its various options. The microprocessor constantly monitors the primary control panel. However, it only monitors the secondary control panel when the printer is offline. When it detects a change in a switch position on either control panel, the microprocessor proceeds accordingly, displaying the change in the indicator lights, if applicable.

The Keyboard and Numeric Pad

The keyboard and numeric pad are input devices which allow you to communicate with your communications system. Like other subsystems, the microprocessor monitors the keyboard and numeric pad. When the operator presses a key, the microprocessor retrieves the keyed character's 7-bit ASCII code. If the printer is offline, the microprocessor immediately processes the character. If the printer is online, the microprocessor transmits the 7-bit code to the communications line via the serial interface.

The Parallel Interface

A parallel interface transfers data received from a computer to the microprocessor. Eight data lines transfer data from the computer to the interface 8 bits at a time. A DEMAND line informs the computer when the interface is able to accept data. A second status line, READY, informs the computer when the printer is powered up and online.

ARCHITECTURE

The microprocessor continually checks the interface to see if any data is present. If it finds that a byte has arrived, the microprocessor retrieves this byte from the interface and stores it in memory for processing. The parallel interface can accept data at a rate of up to 5,000 characters/second until the allotted storage area in memory is filled. At this point, the microprocessor processes half of the stored characters before it accepts any additional characters.

The Serial Interface

The serial interface transfers data in either direction between the printer and a communications system. This interface is available on both RO and KSR DASHER TP2 printers. Jumpers select a number of different serial formats. In addition, you may select one of eight different information transfer rates (110, 150, 300, 600, 1200, 1800, 2400, and 4800 baud).

Reception

The serial interface assembles data in an 8-bit buffer as it is received, notifying the microprocessor when the complete byte is present. The microprocessor then retrieves the byte and stores it in memory for processing.

Transmission

When the microprocessor wishes to transmit a character, it first checks the serial interface to see if it is busy transmitting a character. When the interface is idle, the microprocessor transfers the byte (character) to the interface.

Control

The microprocessor may control and read the status of a MODEM through the serial interface. The interface includes signals which allow you to use MODEMs with auto-answer and auto-disconnect features.

Power Supply

The printer's power supply provides six different dc supply voltages from either 120 volt or 220/240 volt ac power sources (47-63 Hz). The design uses pulse-width modulation to regulate the output voltages. In addition, overvoltage and overcurrent detection protect the supply against fluctuations in line voltage.



Chapter 12

FIELD REPLACEMENT UNIT INTERACTION

Introduction

The microprocessor controls the following basic operations in DASHER LP2 and TP2 printers:

- Moving the carriage (printhead)
- Firing the printhead
- Feeding paper through the printer
- Transferring data to and from the printer

This chapter describes the relationships between the circuit boards, mechanical assemblies, and interconnecting cables which perform these operations. The discussion of each operation includes two figures. The first figure shows the location of related hardware, while the second illustrates the flow of control information through that hardware.

We do not attempt to explain the operation of the microprocessor and its related control circuitry because of their complexity. Most of this circuitry resides on the main control board, though the options board (TP2 printers) contains some of it. Information on the operation of DGC's microNOVA (mN601) microprocessor and its supporting circuits may be found in '*microNOVA Integrated Circuits Data Manual*' (DGC No. 014-000074).

If you are interested in more detail, see Appendix E, which includes an Interconnection Diagram illustrating the signals carried by the various internal cables. See also the logic prints listed under Related Documentation at the end of Chapter 1.

Carriage Position Control

The microprocessor moves the carriage and printhead assembly by controlling the motion of the carriage motor. Control signals, originating from the microprocessor on the main control board, pass through the carriage motor drivers on the driver board and "step" (i.e., move) the carriage motor, thereby turning the leadscrew and moving the carriage.

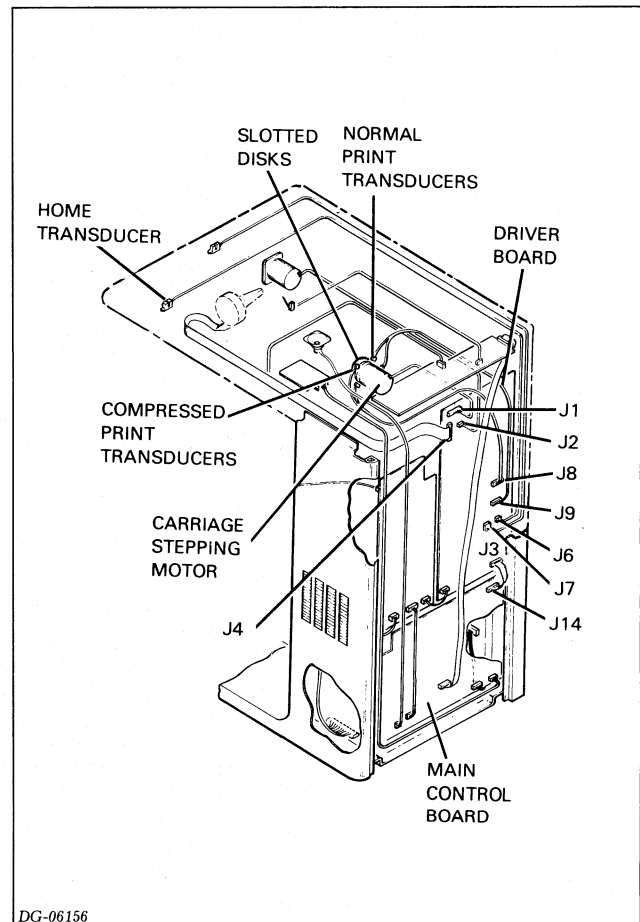

DG-06156

Figure 12.1 Cable Connections, Carriage Control

Detecting Carriage Motion

Located on the motor's drive shaft is a disc (two if the compressed print option is installed) with slots arranged around its periphery. Position Transducers "see" these slits pass by when the motor turns. Signals informing the microprocessor of this motion are detected by the transducer drivers on the driver board and passed back to the control logic on the main control board. The control logic uses this information to check that the carriage moves the correct amount.

A home transducer detects the presence of the carriage at the left-hand margin. It allows the control logic to determine exactly where the left margin is. Once the microprocessor has located the position of the carriage, it keeps track of subsequent motion, using information supplied by the position transducers.

If any part of this loop is broken or not functioning correctly, the microprocessor will signal a problem by turning on the FAULT light on the primary control panel.

Print Control

The microprocessor determines when it should fire the printhead wires according to the position of the carriage. The Home Transducer allows the microprocessor to locate the exact position of the carriage, while the position transducers help the microprocessor keep track of its subsequent motion.

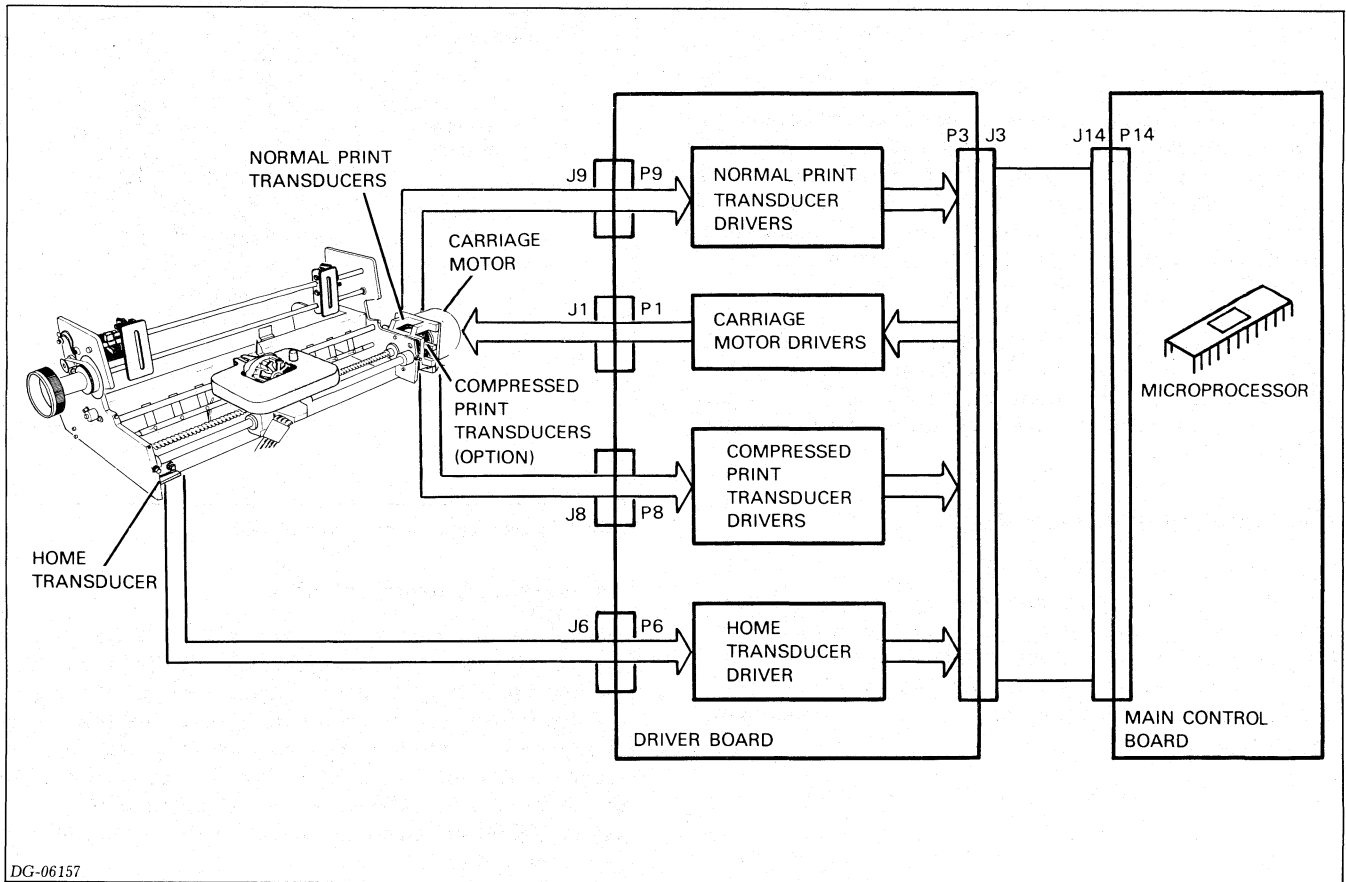

DG-06157

Figure 12.2 Functional Connections, Carriage Control

Determining When to Fire the Printhead

When the carriage motor turns, moving the carriage, it also rotates one or two metal discs. Two transducers are associated with each disc. One disc-transducer set is used while printing normal width characters, while the second set (if installed) is used when printing compressed width characters. Each disc has two kinds of slits: long and short. The long slits, detected by the upper transducer, indicate the beginning of a character. As a result, the upper transducer is called the *start character* transducer. The first 7 of the 9 shorter slits, located between each of the long slits, determine columns within a character (the remaining 2 slits allow for the spacing between characters). The lower transducer of a pair, called the *print* transducer, detects these slits. Together, the start character and print transducers help the microprocessor determine when to fire the printhead.

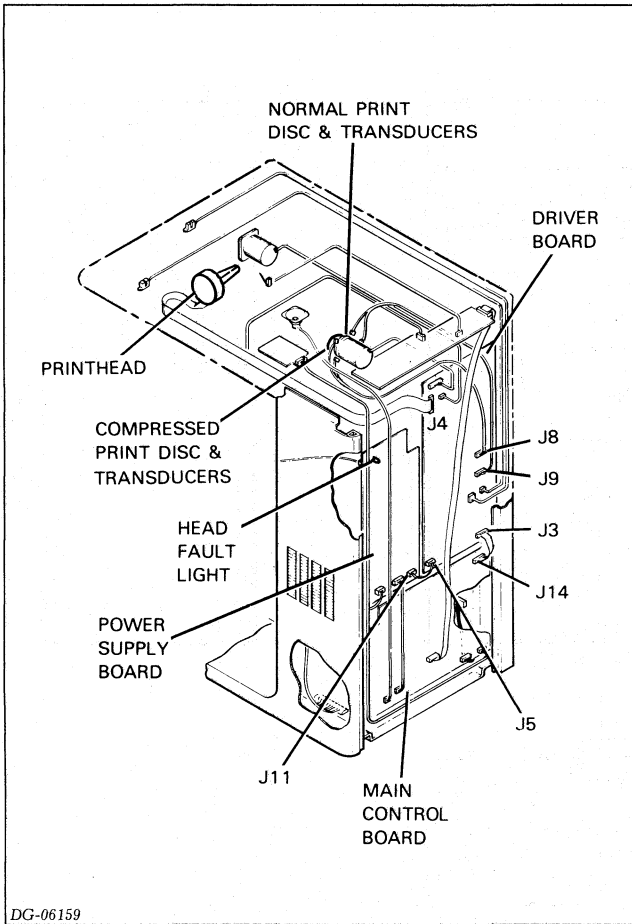

DG-06159

Figure 12.3 Cable Connections, Print Control

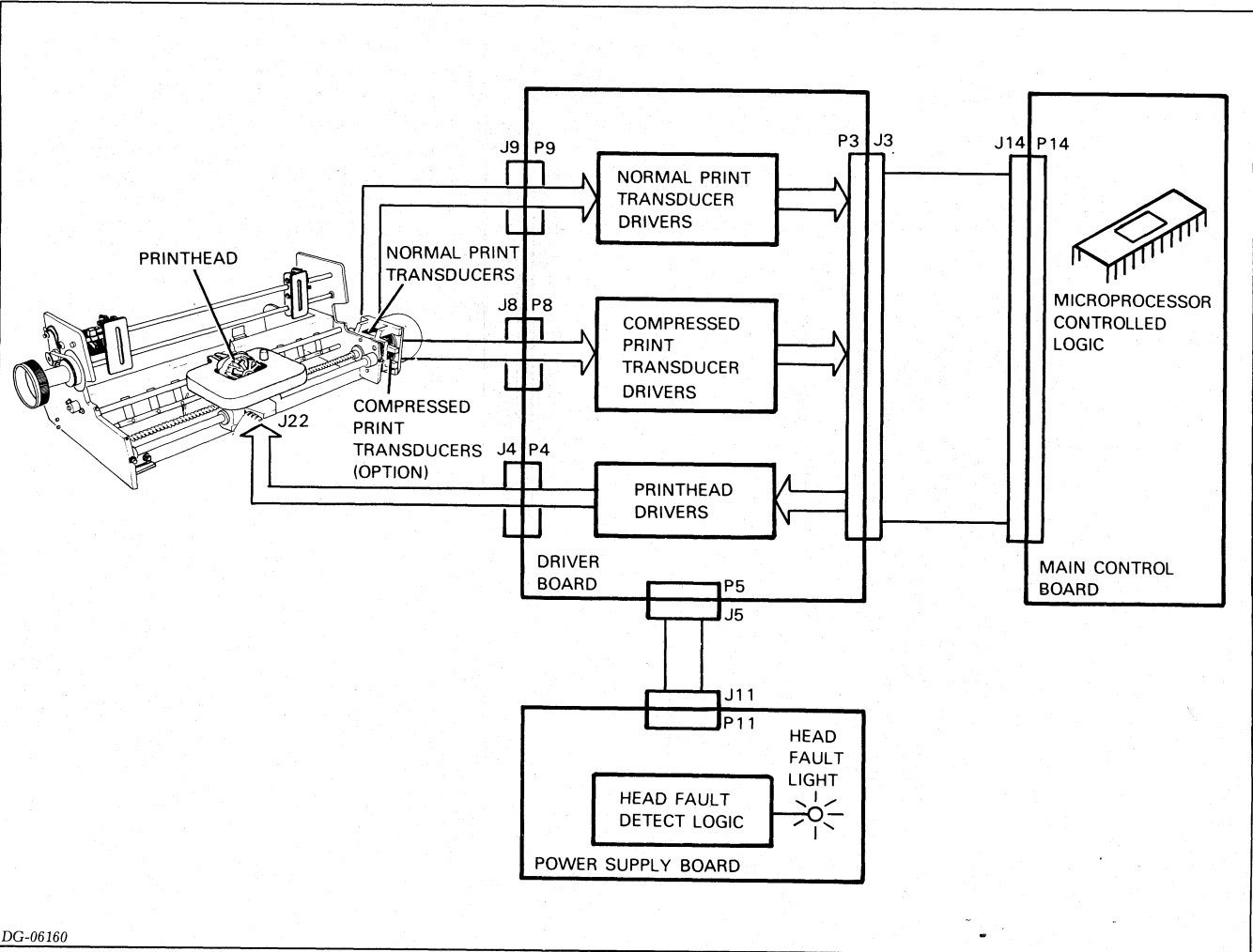

DG-06160

Figure 12.4 Functional Connections, Print Control

FIELD REPLACEMENT UNIT INTERACTION

Two different discs are necessary to allow normal and compressed width characters. The slits in the compressed disk are closer together, causing the microprocessor to print each character's columns closer together.

All the signals generated by the transducers pass through the driver board and are made available to the microprocessor on the main control board. The microprocessor can print either normal or compressed width characters by selecting information from the appropriate pair of transducers.

Firing The Printhead

The microprocessor fires the printhead via control logic on the main control board. This logic passes a 9-bit code to the driver circuitry on the driver board which in turn energizes the appropriate coils in the printhead. When a printhead coil is energized, it sets up a magnetic field forcing a print wire out of the printhead. The print wire forces the ribbon against the paper, forming one part of the dot matrix character.

If for some reason a coil in the printhead is energized for too long a period, or a printhead winding shorts out, an overcurrent sensing circuit shuts down the power supply. In this case, a HEAD FAULT light on the power supply board indicates the cause of the shutdown.

Paper Feed Control

The microprocessor moves paper through the printer, passing it vertically by the printhead. Paper may be advanced in only one direction. Control signals, originating from the microprocessor on the main control board, pass through the paper feed drivers on the driver board and turn the paper feed motor. The motor advances the paper via the remainder of the paper feed mechanism.

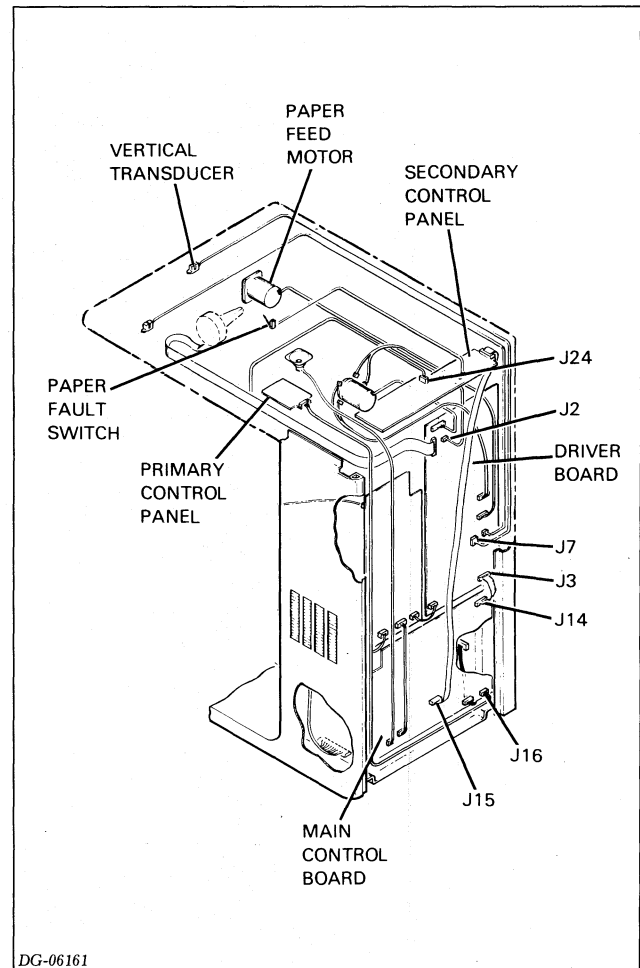

Figure 12.5 Cable Connections, Paper Feed Control

Detecting Paper Motion

A slotted disk and transducer pair inform the microprocessor of any paper motion. The slotted disk is mounted on the paper feed assembly's main drive shaft (near the hand advance knob). When the drive shaft turns, the slots in the disk pass by the vertical transducer. As a result, the microprocessor can check to make sure the paper feed motor advances the correct amount. If the paper motion detected by the vertical transducer does not match the programmed paper movement, the microprocessor signals a fault by placing the printer offline and turning on the FAULT light.

Sensing The Presence Of Paper

Another feedback mechanism is the Paper Fault switch, which determines the presence or absence of paper. The state of this two position micro-switch is fed back to the microprocessor via the secondary control panel. When the Paper Fault switch detects an absence of paper, the microprocessor completes printing the present line, places the printer offline, and turns on the FAULT light.

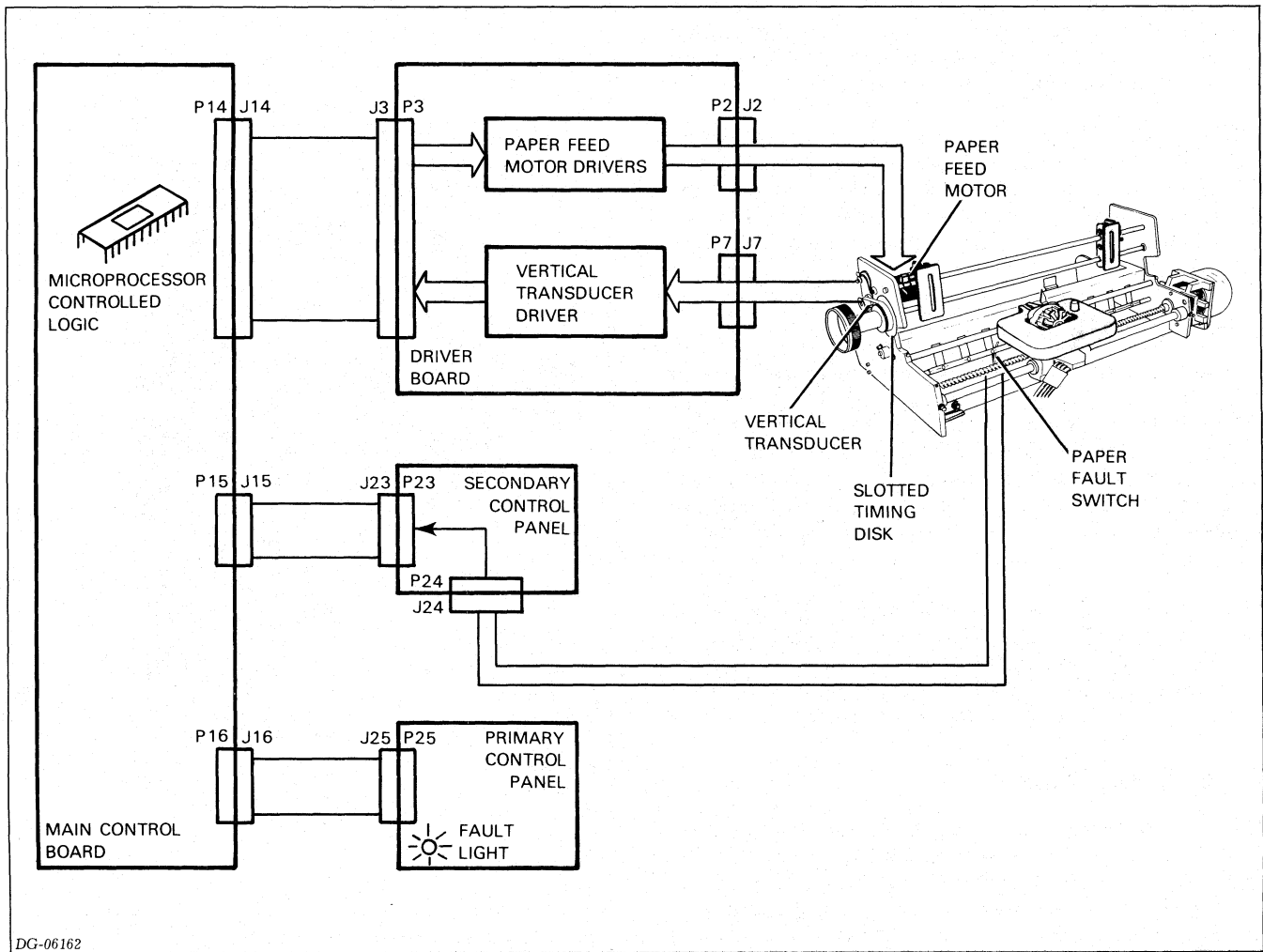

DG-06162

Figure 12.6 Functional Connections, Paper Feed Control

Data Reception and Transmission

The microprocessor controls the interface which allows a printer to receive and transmit data. A DASHER LP2 printer's parallel interface resides on the main control board while the DASHER TP2 printer's serial interface resides on the options Board. Both interfaces notify the microprocessor when they receive data. The microprocessor then retrieves the data and processes it appropriately.

FIELD REPLACEMENT UNIT INTERACTION

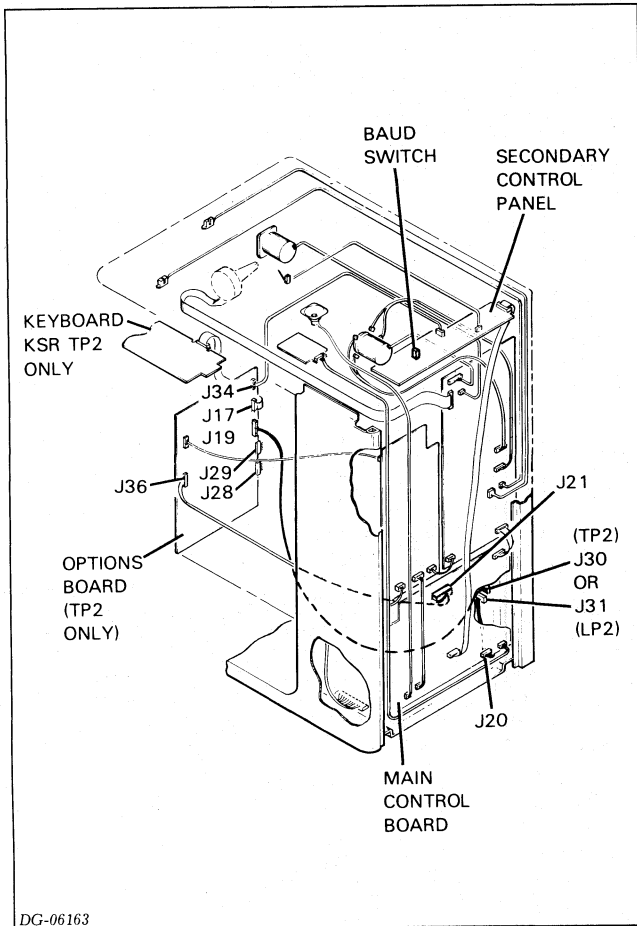
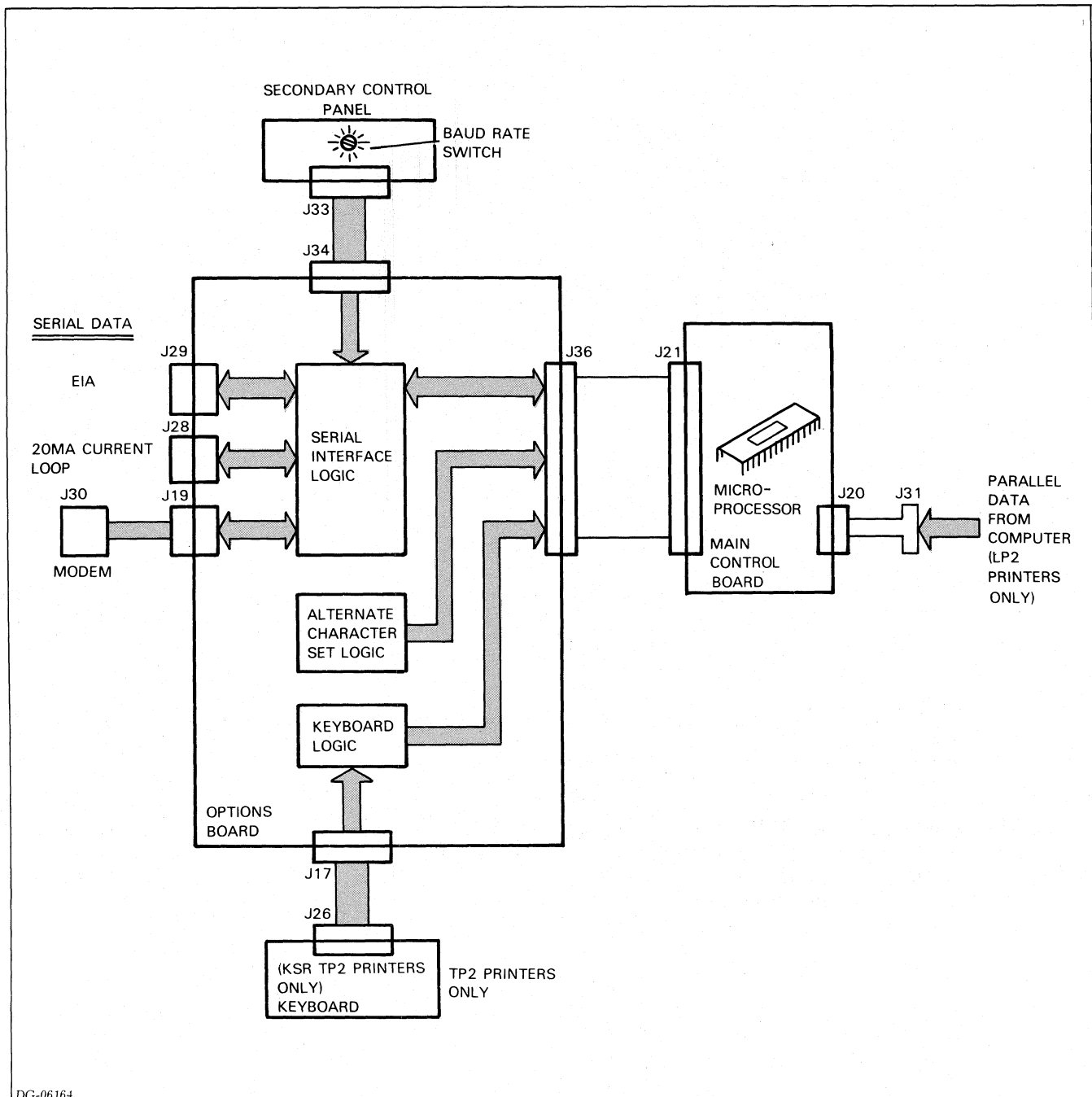

Figure 12.7 Cable Connections, Data Flow

The options board also contains much of the control logic for the alternate character set option and the keyboard option available on TP2 printers.



DG-06164

Figure 12.8 Functional Connections, Data Flow

Power Supply Distribution

The power supply board distributes d.c. supply voltages to the main control board, the driver board, and the options board. It receives either 110 or 220 volt power from the line filter located in the bottom of the cabinet.

Two power cords are available for DASHER LP2 and TP2 printers: one for 120 volt operation and one for 220/240 volt operation. The wiring of the connector on the printer end of each cord (J27) selects the appropriate input wires to the power supply board. This way, the power cord automatically selects the appropriate input circuit on the

power supply board for the given supply voltage.

The power supply has one indicator light whose purpose is described in Chapter 15.

FIELD REPLACEMENT UNIT INTERACTION

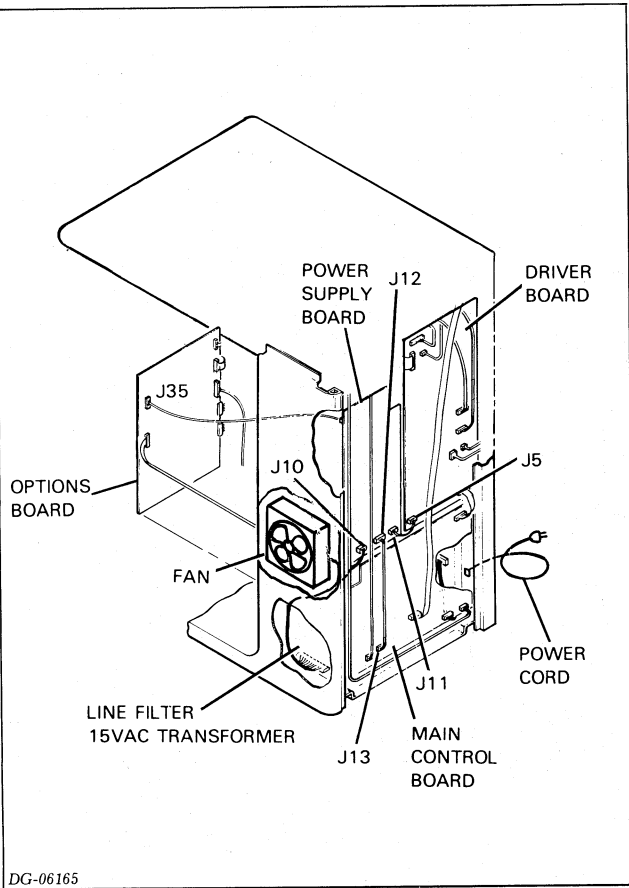
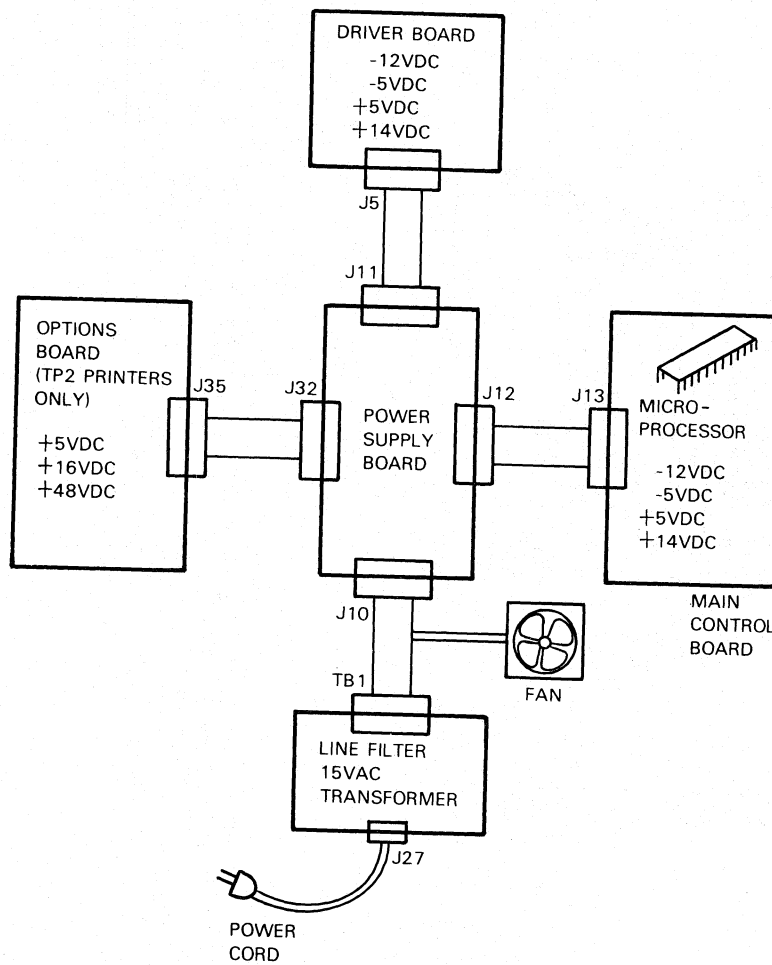

Figure 12.9 Cable Connections, Power Supply



DG-06166

Figure 12.10 Functional Connections, Power Supply

Part 4 Maintenance



Chapter 13

GENERAL INFORMATION

This section contains procedures for maintaining, replacing, and adjusting various assemblies in DASHER LP2 and TP2 printers. Chapter 14 contains preventive maintenance procedures which should be carried out at three month intervals. Chapter 15 contains replacement procedures for all of a printer's major assemblies and subassemblies. Chapter 14 contains all of the adjustment procedures.

When replacing an assembly or subassembly, make sure you perform all the necessary adjustments. After replacing a part, use the Replacement/Adjustment Chart (Figure 13.1) as a quick reference to ensure that you perform the appropriate adjustments in the correct order.

Two additional diagrams, included in Appendix F, describe the routing of the various internal cables and illustrate the signals they carry. These diagrams are very useful when replacing circuit boards or when performing any replacement procedure which involves disconnecting many of the internal cables. It is always a good idea to double check your work.

Warning: *When working inside the printer, be extremely careful of high voltages on the Power Supply Board. Some of the voltage levels are lethal. When replacing the Power Supply Board, wait at least 5 minutes after turning off the printer before removing the board.*

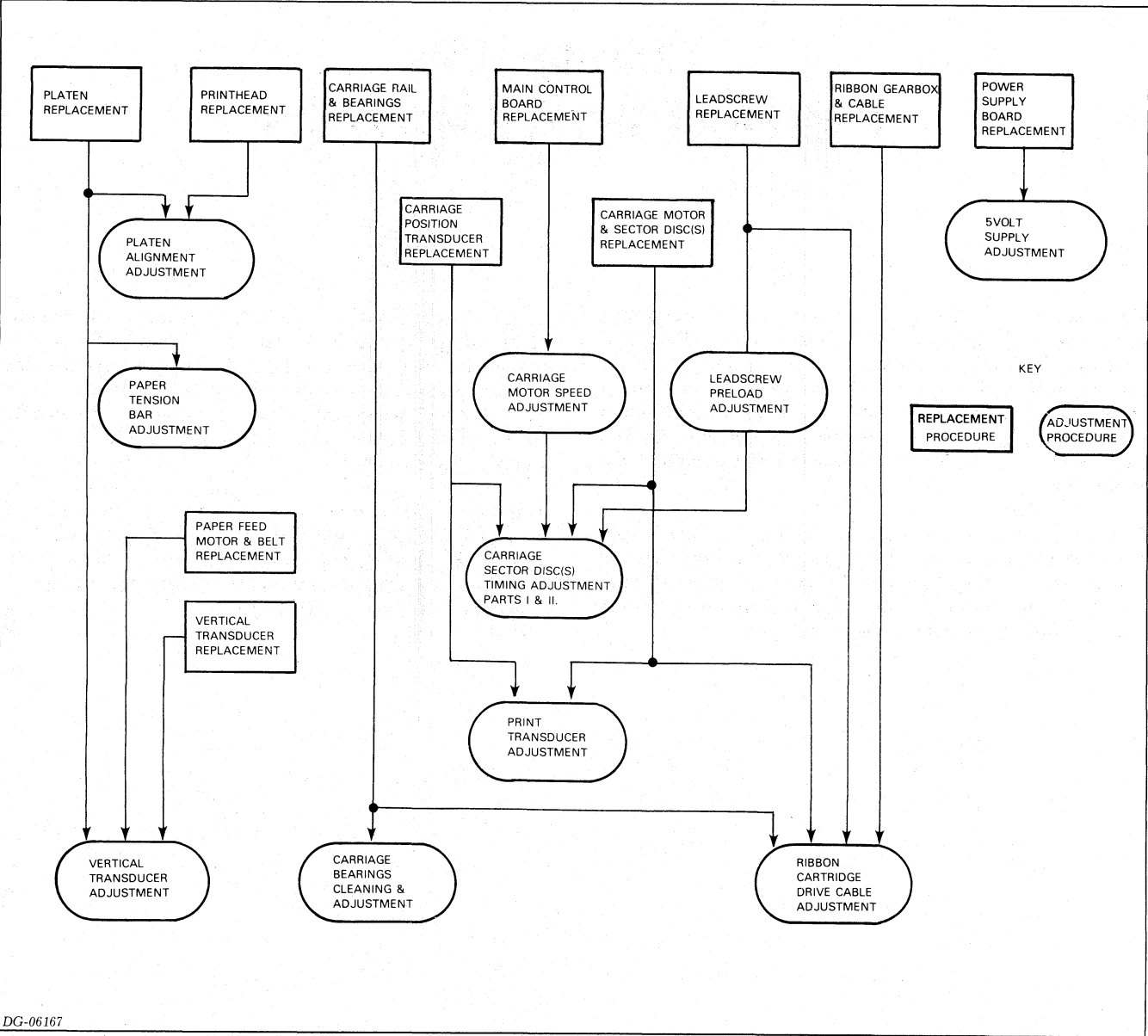

DG-06167

Figure 13.1 Replacement/Adjustment Chart

Chapter 14

PREVENTATIVE MAINTENANCE PROCEDURES

Introduction

A DASHER LP2 or TP2 printer should have a minor cleaning once a month, followed by a major cleaning, adjustment, and checkout every three months. The monthly cleaning should be performed by the operator as outlined in *DASHER LP2 and TP2 Operator's Manual* (DGC No. 014-000094). The three-month procedures should be performed by a DGC Field Engineer, if the printer is on a service contract, or by the customer. The three month procedures are outlined below.

Three-Month Procedures

Interval: 3 months

Completion Time: 30 min.

Tools: F. E. Standard Tool Kit 005007791

Grease 120000753

Isopropyl Alcohol 91%

Vacuum Cleaner 128000734

Soft Bristle Brush 128000186

Lint-Free Tissue 119000062

Belt Tension Hanger 128000787

Terminal Tester (120 VAC) 005010682

(220/240 VAC) 005010687

Reliability Program see Chapter 8,

Preparing Unit

1. Run LP2/TP2 Reliability Test (see Chapter 8) or use the Terminal Tester (see Chapter 9) to verify printer operation.
2. Switch the printer offline.
3. Turn off the printer and remove the paper.
4. Unplug the power cord from the AC outlet.
5. Swing the top cover up until it latches.
6. Remove the pedestal's right and left side access doors.

General Cleaning

Vacuum the top and bottom areas using a non-conductive crevice nozzle. **Caution:** Extreme care should be taken to prevent physical damage to all electronic and mechanical parts with the vacuum cleaner nozzle.

Cleaning Printhead Jewel

1. Remove the ribbon cartridge.
2. Remove the printhead (see Chapter 15, Printhead Replacement).

Caution: Handle the printhead with care.

3. Clean the printhead face jewel with a soft bristle brush.
4. Wipe the printhead face jewel using lint-free tissues and alcohol.

NOTE: *Printhead wires extend beyond the jewel; therefore, after cleaning, ensure that tissue remnants and/or caked ink are totally removed from the jewel and wires.*

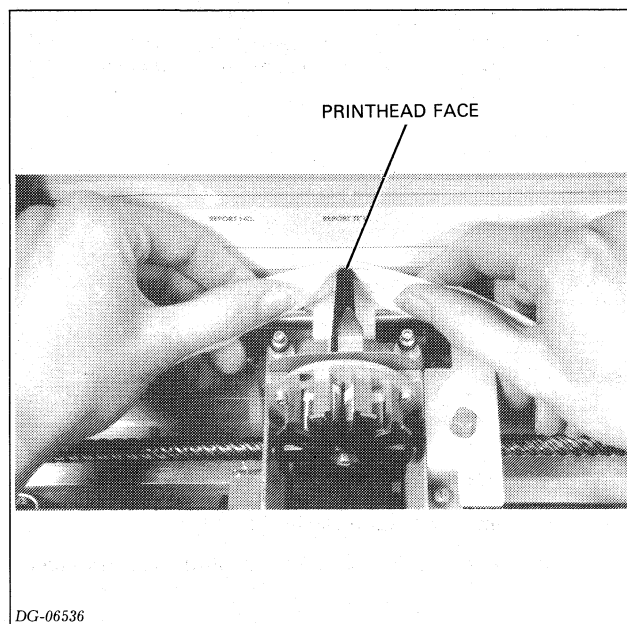

Figure 14.1 Cleaning printhead face

Cleaning Transducers and Timing Discs

Caution: Do not bend the code discs or disturb any of the transducers' settings.

1. Carefully clean the carriage position transducers and timing disc(s), using a soft bristle brush. Gain access to all a disc's timing slits by manually rotating the leadscrew.

- Clean the paper feed transducer and timing disc with a soft bristle brush. Gain access to all the disc's timing slits by manually rotating the tractor drive shaft.
- Clean the home transducer with a soft bristle brush.

NOTE: After cleaning all the code discs, ensure that all the timing slits are clear.

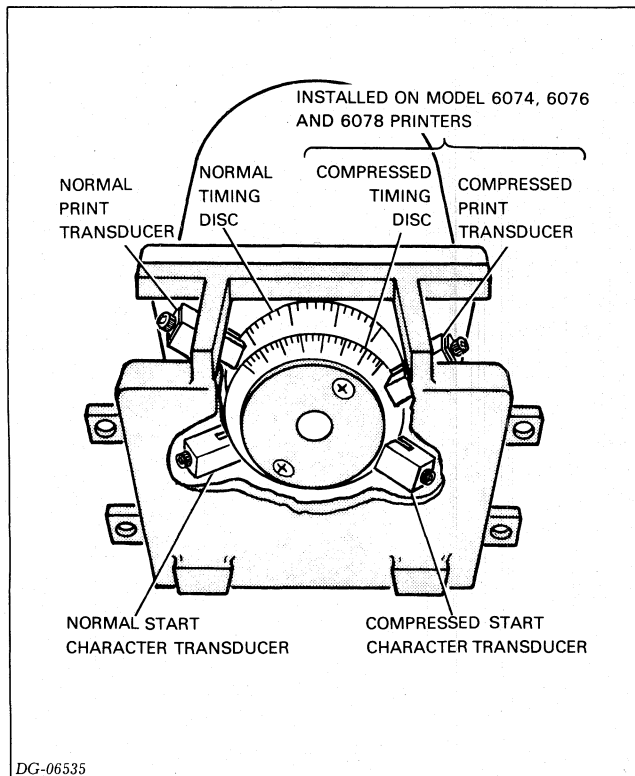

Figure 14.2 Transducers and timing disc locations

Cleaning Lead Screw and Guide Rails.

- Clean the lead screw with alcohol and lint-free tissues.
- Caution:** Do not leave any foreign material in the lead screw's grooves, since this will affect the printer's performance.
- Move the carriage assembly to the left carriage stop.
 - Clean the lead screw again as in step a.
 - Clean the rear guide rail with alcohol and lint-free tissues.

Checking Linear Bearings and Front Guide Rails

- Clean the front guide rail with a lint-free cloth. **DO NOT USE ALCOHOL.**
- Move the carriage assembly between the right and left carriage stops (3 times each direction).
- Check the front guide rail for a slight evidence of grease from the linear bearings. If you see no grease, repack the bearings with grease (see 'Carriage Bearings Cleaning and Adjustment Procedure', Chapter 16).
- Rub a thin coat of grease on the front carriage guide rail.

Checking the Ribbon Drive Cable Tension

- Check the ribbon drive cable tension (see 'Ribbon Cartridge Drive Cable Adjustment', Chapter 16).
- Reinstall the printhead (see 'Printhead Replacement', Chapter 15).

Restoring the Printer

- Reinstall the ribbon cartridge.
- Reinstall the two pedestal access panels.
- Reinstall paper and close the top cover.
- Plug the power cord into the AC outlet.
- Turn on the power.

Checking Anti-Backlash Nut

Print a page of "H's" using either the terminal tester or test #17 of the reliability program. If the leading and trailing edge of each column of H's do not line up, the anti-backlash nut and lead screw may need replacement. However, first perform the following adjustments (see Chapter 16):

- Carriage Sector Disc(s) Timing Adjustment: I and II
- Print Transducer(s) Adjustment

If the problem persists, replace the lead screw and anti-backlash nut (see "Anti-backlash Nut and Lead Screw Replacement", Chapter 15).

Verifying Printer Operation

Verify that the entire printer is operating correctly, using the LP2/TP2 reliability program (Chapter 8) or the terminal tester (Chapter 9). 10. Verify that the entire printer is operating correctly using the LP2/TP2 reliability program (Section II, Chapter 6) or the terminal tester (Section II, Chapter 7).

Chapter 15

REPLACEMENT PROCEDURES

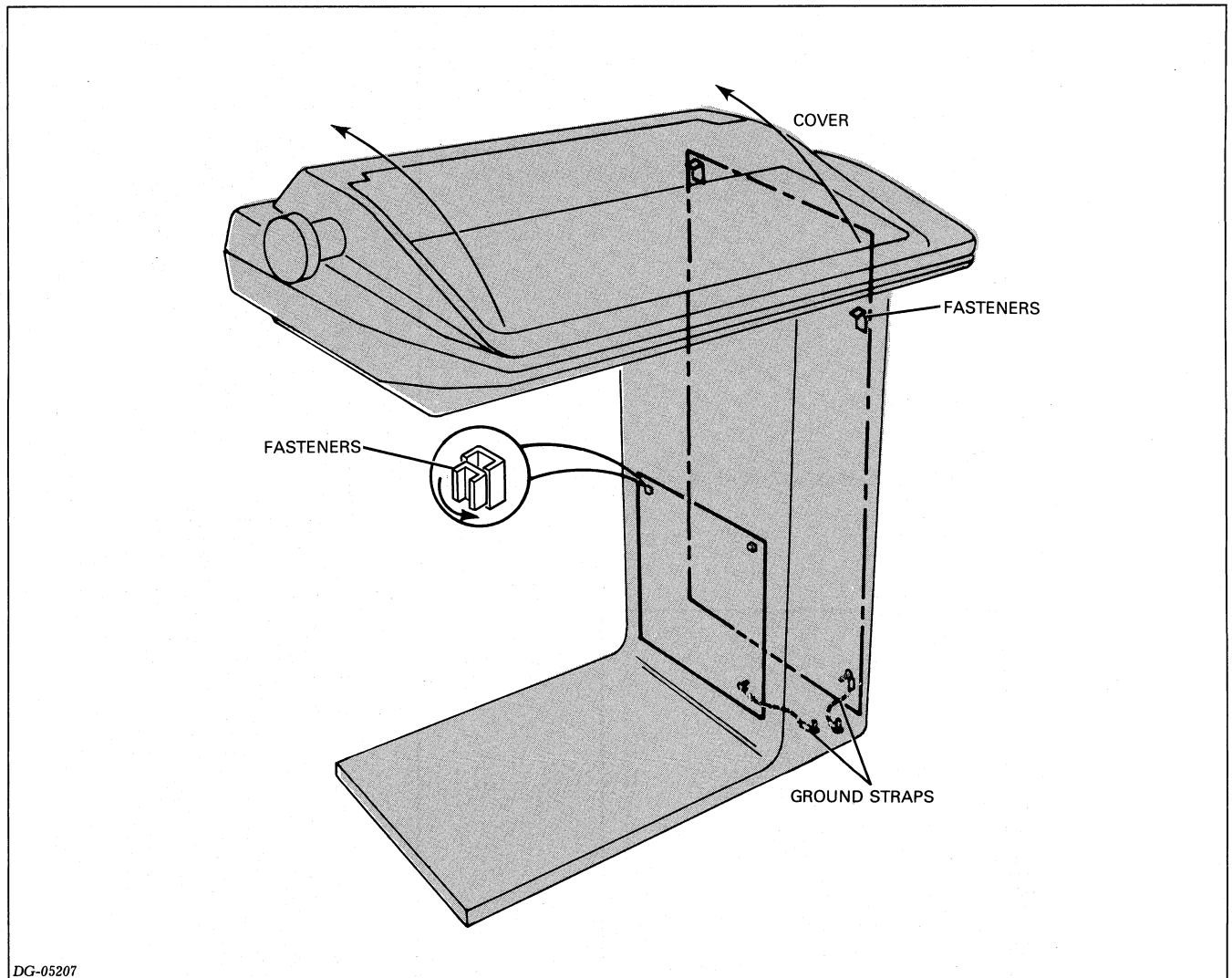

DG-05207

Figure 15.1 Access Panels

--CAUTION--

Be sure the power cord is unplugged from the wall or from the rear of the unit before removing any of the cable connectors or boards.

- 1 Label all of the cable connectors with their respective J numbers. Unplug all the cable connectors from the board.

Note:

The Power PC Board has a cover which must be removed before the board.

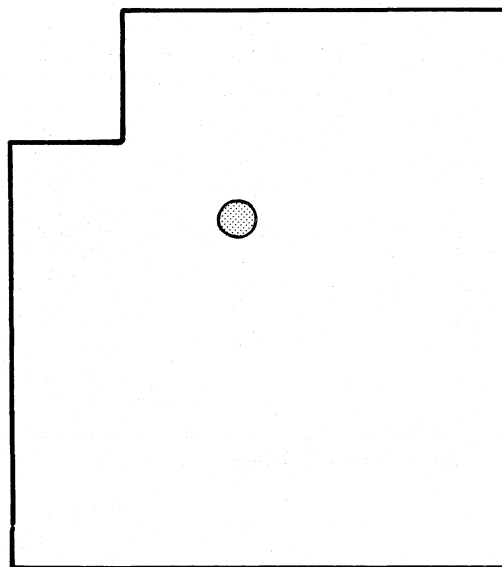
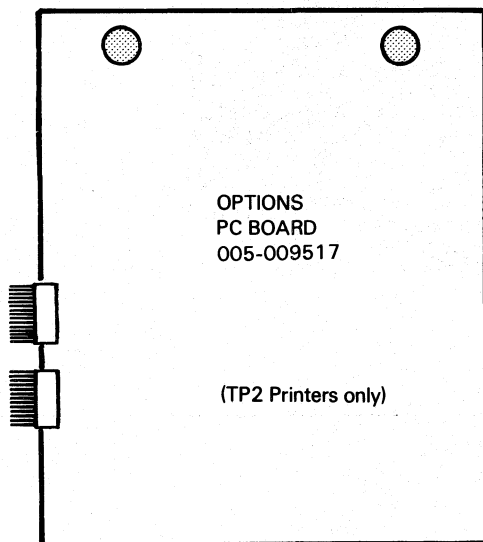
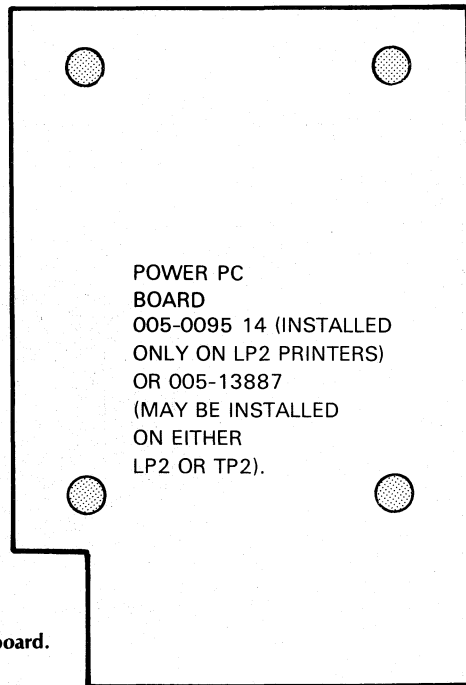

REPLACEMENT PROCEDURES

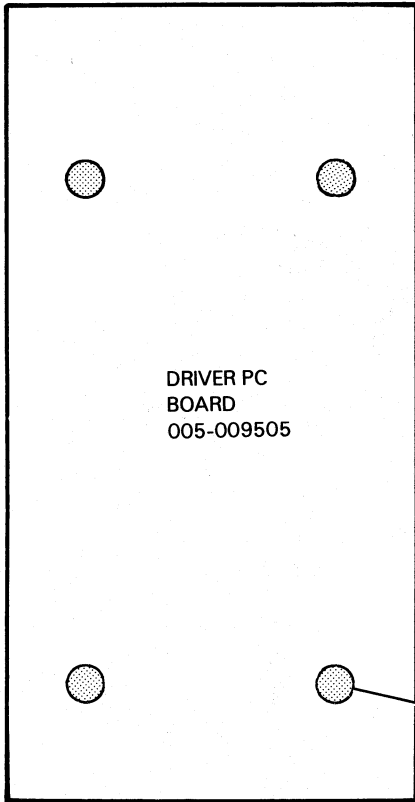

2 Pull the release knobs (they will click when open). Remove the board.

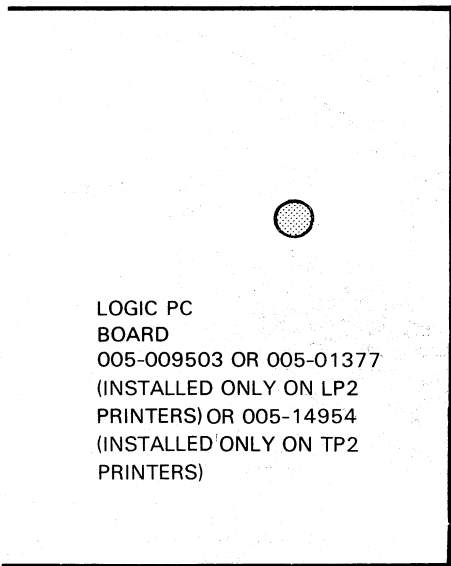
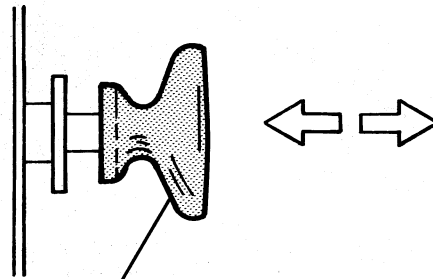

3 Place the new board in position and push on the retainer knobs (they will snap closed).

4 Reconnect all the cables to the board. (see Internal Cabling).

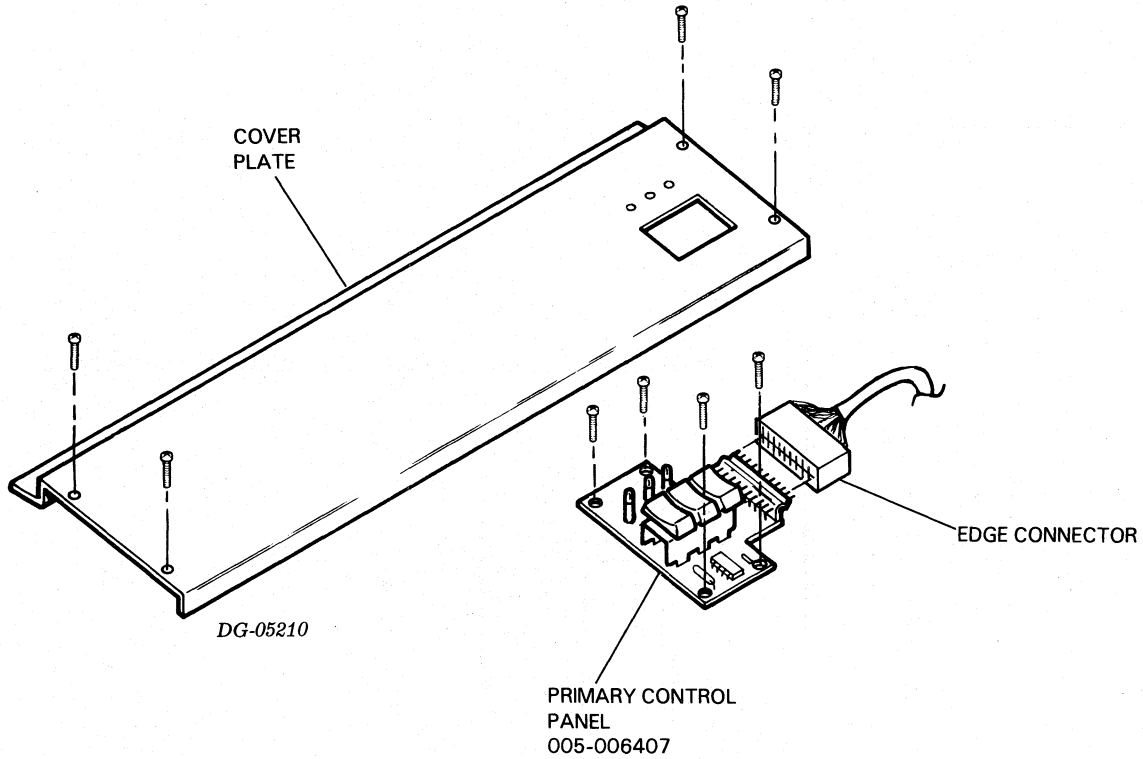

CONTROL PANELS REPLACEMENT

- 1 Remove the cover plate.
- 2 Unplug the edge connector from the board.
- 3 Remove the board. Attach the new board.
- 4 Refasten the edge connector.
- 5 Attach the cover plate.

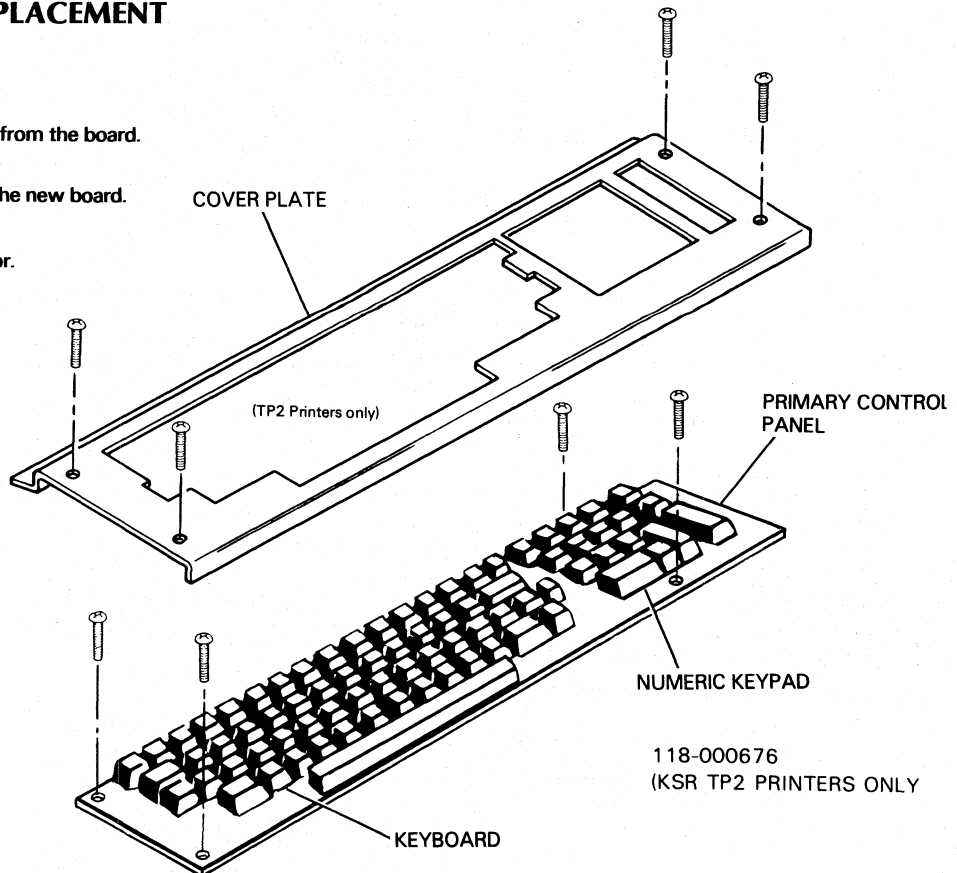

DG-06169

Figure 15.3 Control Panels Replacement

REPLACEMENT PROCEDURES

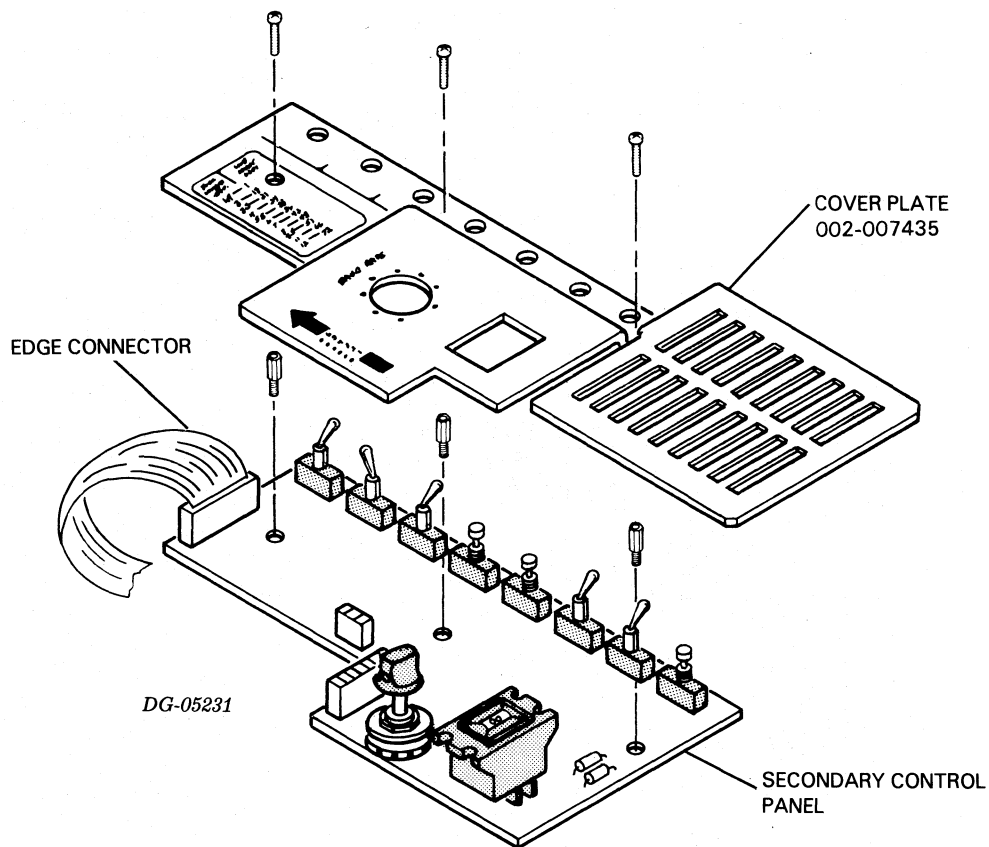

**OPTIONAL SECONDARY CONTROL PANELS		
MODEL	CHARACTERISTICS	SECONDARY CONTROL PANEL 005 -
6073 60Hz 50Hz	RECEIVE ONLY PRINTER, AUTOMATIC FORM FEED	005-010699
(S) 6073 60Hz	RECEIVE ONLY PRINTER	005-011978
6074 60Hz 50Hz	COMPRESSED PRINT RECEIVE-ONLY PRINTER, AUTOMATIC FORM FEED, PARALLEL INTERFACE	005-011991
6075 60Hz 50Hz	RECEIVE ONLY PRINTER, AUTOMATIC FORM FEED, SERIAL INTERFACE	005-011989
(S) 6075 60Hz	RECEIVE ONLY PRINTER, SERIAL INTERFACE	005-010015
6076 60Hz (S) 6076 60Hz 6076 50Hz	RECEIVE ONLY PRINTER, AUTOMATIC FORM FEED, SERIAL INTERFACE, COMPRESSED PRINT	005-009519
6077 60Hz 50Hz	KEYBOARD SEND/RECEIVE TERMINAL, AUTOMATIC FORM FEED, SERIAL INTERFACE, KEYBOARD, NUMERIC PAD	005-011989
(S) 6077 60Hz	KEYBOARD SEND/RECEIVE TERMINAL SERIAL INTERFACE	005-010015
6078 60Hz 6078 50Hz (S) 6078 60Hz	KEYBOARD SEND RECEIVE TERMINAL, AUTOMATIC FORM FEED, SERIAL INTERFACE, NUMERIC PAD, COMPRESSED PRINT	005-009519

- 1 Open the top cover and remove the ribbon cartridge.

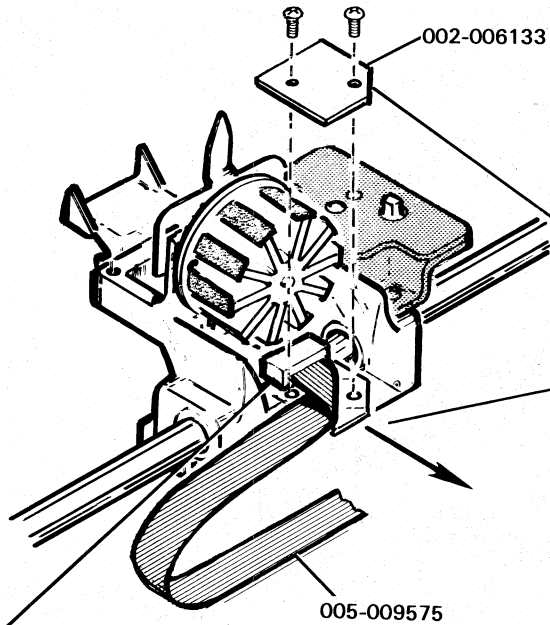

- 3 Remove the cable clamp.
Unplug the cable from the printhead.

- 5 Secure the new printhead in place. Plug in the cable and secure it with the cable clamp. Do not pinch the cable.

Note:

When plugging in the cable, always keep the brown wire to the left and the black wire to the right.

- 6 Adjust the spacing between the printhead and the platen (See Platen Alignment Adjustment). Replace the ribbon cartridge.

DG-06170

Figure 15.4 Printhead Replacement

REPLACEMENT PROCEDURES

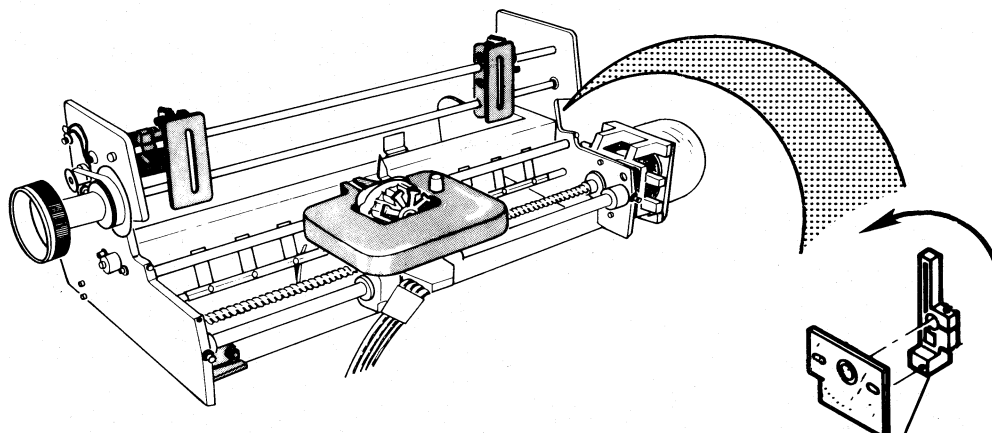

2 Rotate the platen position lever to its rear most position.

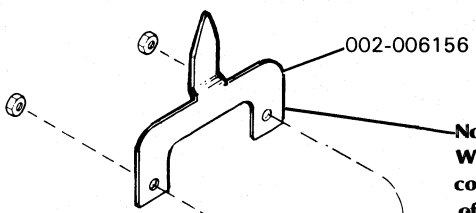

Note:
When fastening the printhead check that the column indicator is displaced to the right of center.

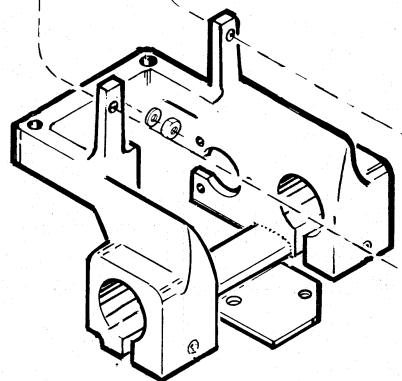

4 Remove the two screws attaching the printhead to the carriage.

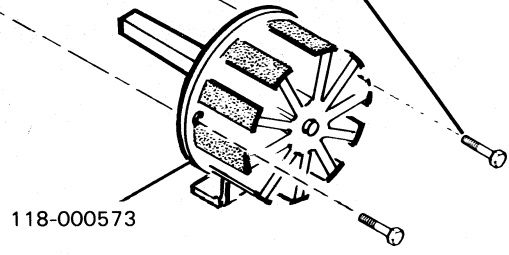

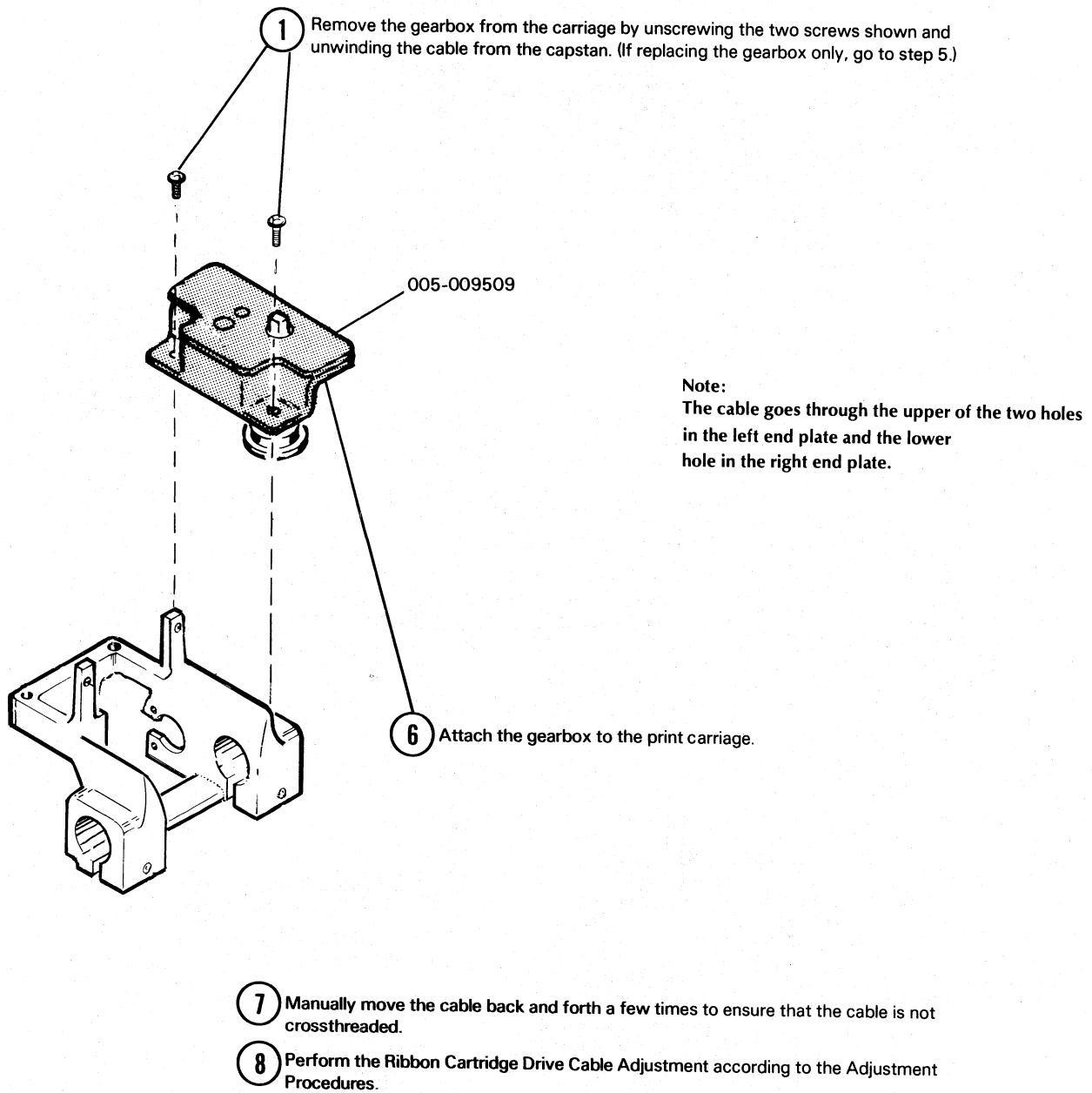

DG-05212

Figure 15.5 Ribbon Gearbox & Cable Replacement

REPLACEMENT PROCEDURES

- 2 Remove the cable keeper and pull the cable to the left out of the frame.

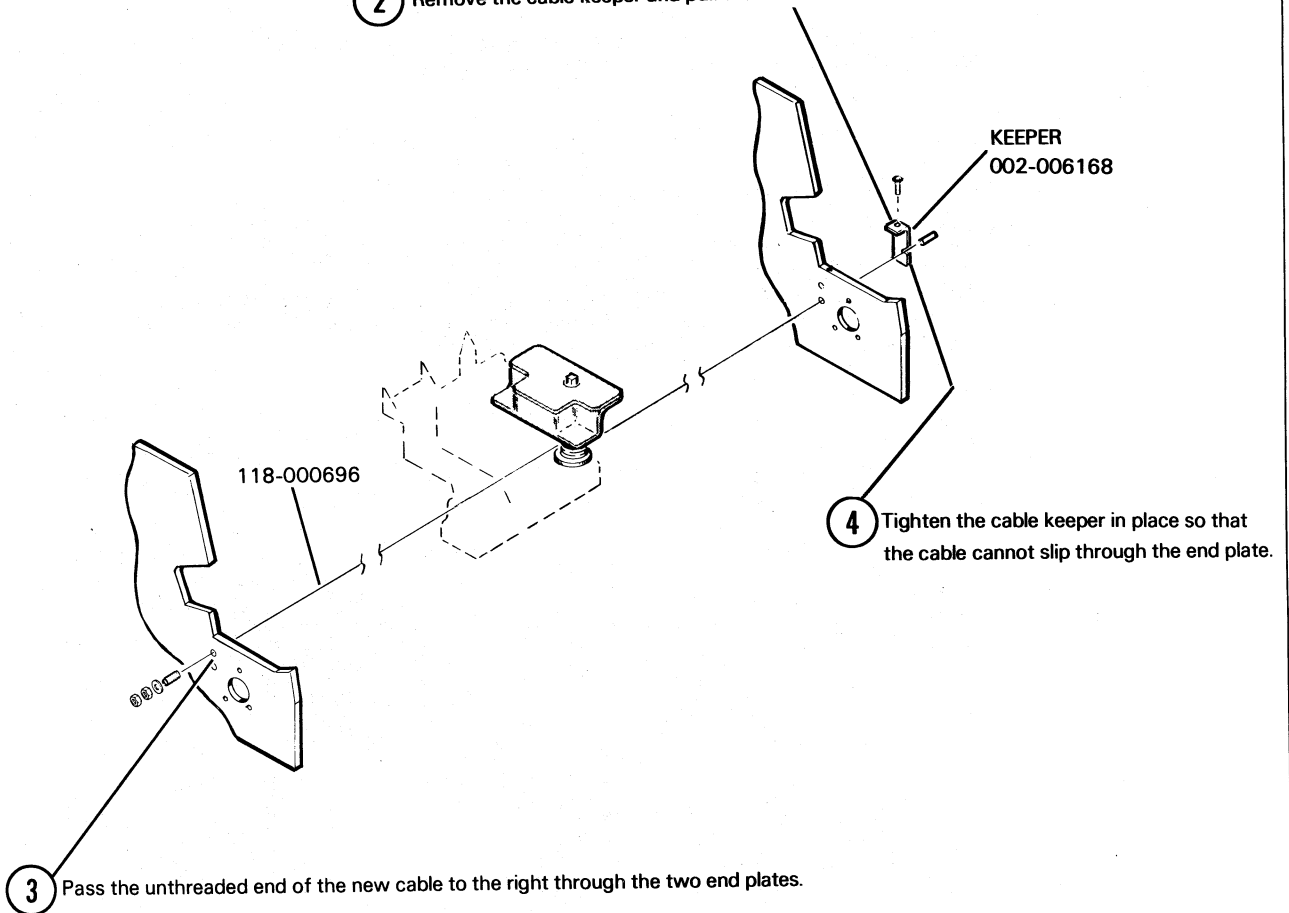

- 5 Wind the cable three turns around the gearbox capstan as shown.

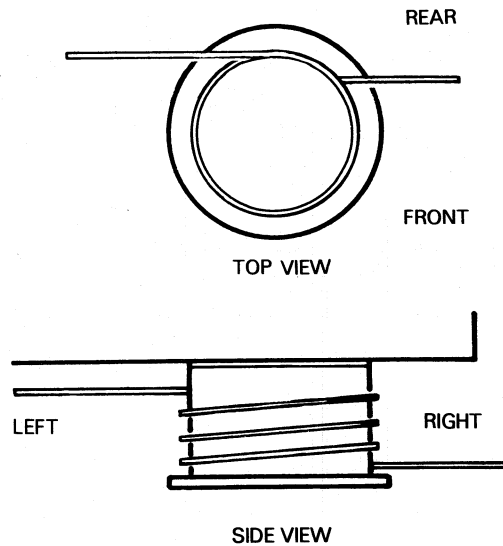

NOTE:

The anti-backlash nut and leadscrew come in a matched set (DGC part 118-000675). To insure proper operation, you should replace them only in pairs.

- 1 Remove the gear box (see Ribbon Gearbox Replacement).
- 2 Remove the secondary control panel cover (see Control Panel Replacement).
- 3 Remove the carriage motor assembly from the right end plate by removing the three screws securing the motor mounting bracket. Carefully place the assembly on top of the secondary control panel PC board. (There is no lock washer on this screw.)

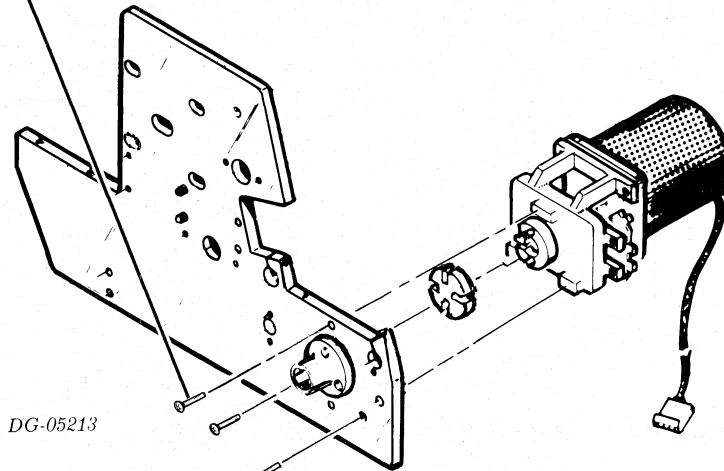

- 14 Attach the carriage motor assembly to the right end plate with the three #8 hex head cap screws. Make sure the plastic coupling adapter is in place. Ensure that the slide coupler is not compressed between the coupling clamps.
- 4 Slide the carriage all the way to the left. Loosen the coupling clamp using a 3/32 inch Allen wrench, and slide the coupling off of the leadscrew.
- 5 Remove the bearing retainer plate, being careful not to lose the wavy washer.

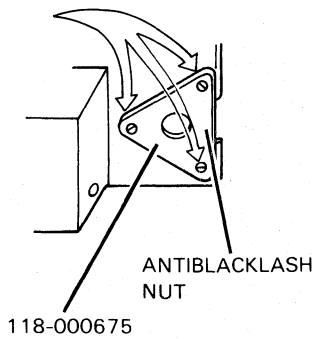

7 Without allowing the antiblacklash nut to come off the leadscrew, partially withdraw the leadscrew through the right end plate until it clears the carriage. Then pull the leadscrew and nut assembly to the right and out of the end plate.

8 Measure stand-alone lead screw torque as follows. Attach the torque watch to the lead screw. Grasp the anti-backlash nut and hold the lead screw in a horizontal position. Rotate the lead screw through the anti-backlash nut and observe the torque reading (which should fall between 2 and 4 inch oz.).

9 Insert the right end of the new leadscrew through the righthand bearing retainer and into the right end plate until you can pass the left end through the hole in the carriage. Attach the antiblacklash nut to the carriage, using the three #8 screws.

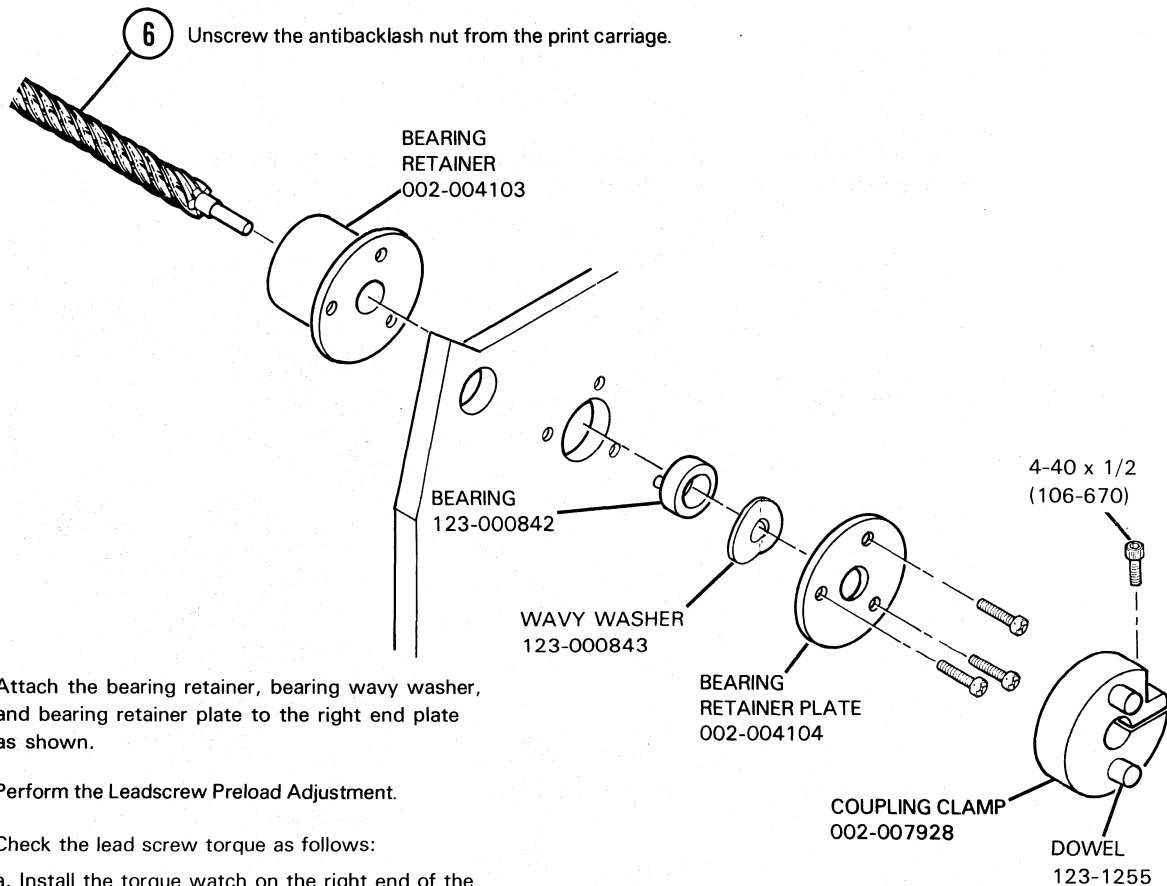

10 Attach the bearing retainer, bearing wavy washer, and bearing retainer plate to the right end plate as shown.

11 Perform the Leadscrew Preload Adjustment.

12 Check the lead screw torque as follows:

- Install the torque watch on the right end of the lead screw.
- Turn the lead screw with the torque watch (the torque required to move the carriage should not exceed 6.5 inch oz.).
- If the torque exceeds 6.5 inch oz., check the linear bearings, rear bearing and guide shafts.

13 Refasten the carriage motor coupling so that its face is flush with the end of the leadscrew. Tighten clamp screw from 80 to 120 in. ozs. (5 to 7.5 in. lbs.).

15 Install the gearbox (see Ribbon Cartridge Gearbox Replacement).

16 Install the secondary control panel (see Control Panel Replacement).

17 Perform the Carriage Sector Disc(s) Timing Adjustments Parts I and II.

- 1 Remove the secondary control panel cover.
- 2 Remove the carriage motor assembly from the right end plate by removing the three screws securing the motor mounting bracket.
- 3 Remove the coupling clamp from the motor shaft.
- 4 Remove the carriage position transducer assembly (both assemblies if equipped with compressed print option) by unscrewing the screws as shown.

Note:
If there are two transducer assemblies, make sure they go back in their original positions.

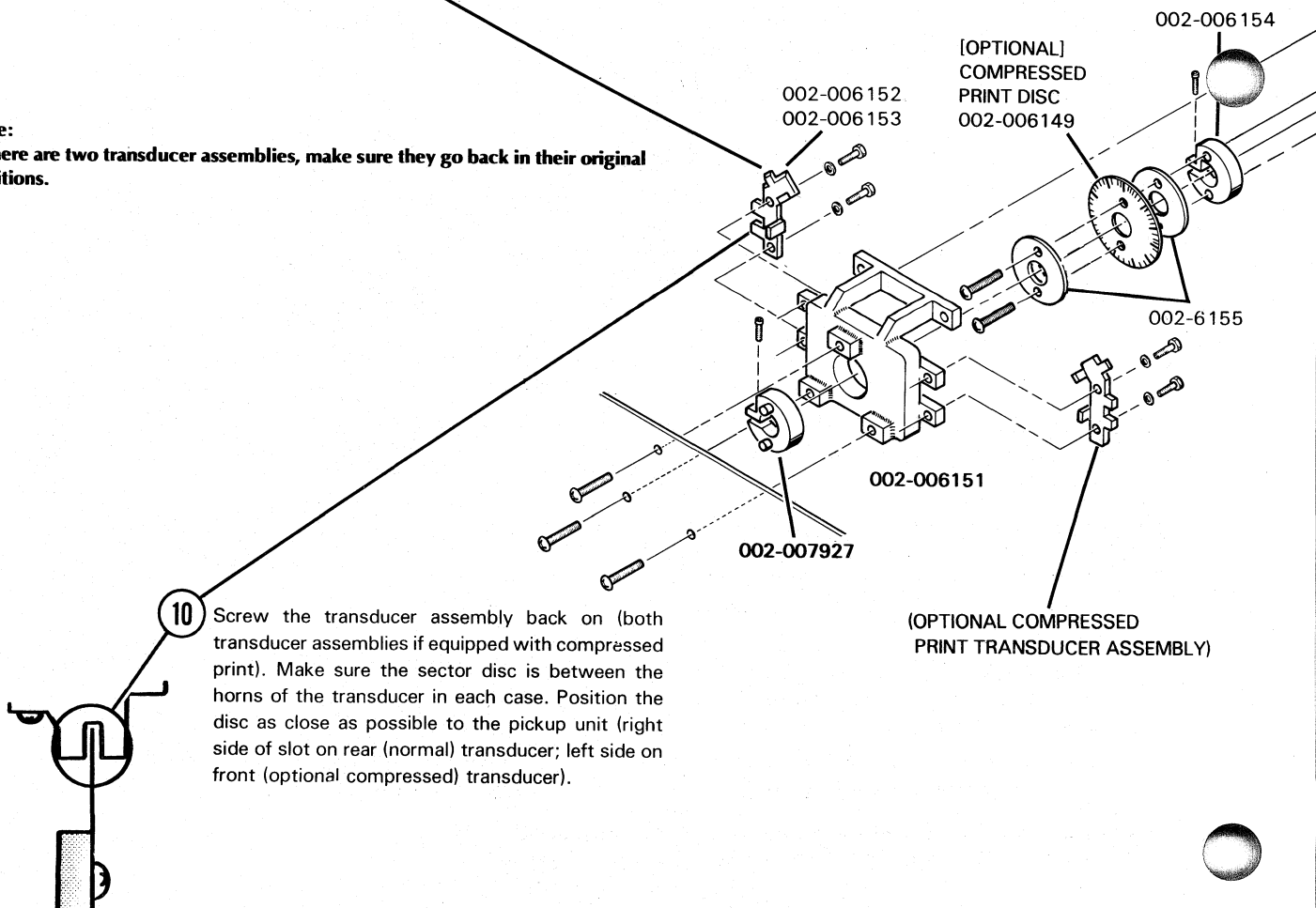

DG-06172

Figure 15.7 Carriage Motor and Sector Disc(s) Replacement

- CAUTION -

The sector disc is very fragile. Carefully support the motor when removing the last screws, and be sure not to bend the sector disc when removing the motor from its mount.

6 Remove the motor from its mounting by unscrewing the four self-tapping screws.

5 Unplug the motor drive cable from connector J1 on the Driver PC board. Cut any ties securing the cable.

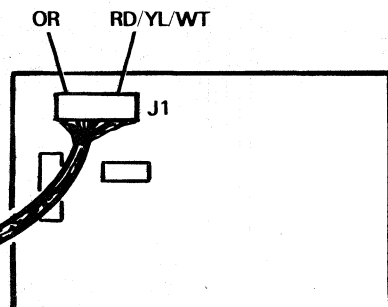
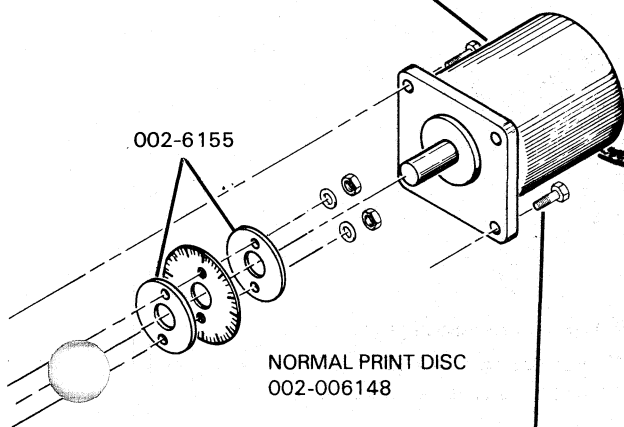

11 Connect the motor drive cable to J1 on the Driver PC board.

9 Fasten the motor to its mount using the four #10 self-tapping screws.

7 Using a 3/32 in. Allen wrench, loosen the coupling clamp and sector disc(s) and slide them off the motor shaft.

8 Reposition the sector disc(s) and coupling loosely on the motor shaft. With the coupling flush on the end of the shaft, tighten the coupling clamp screw from 80 to 100 in. ozs. (5 to 7.5 in. lbs.) Do not tighten the sector disc(s) clamp screw yet.

12 Perform the Carriage Sector Disc(s) Timing Adjustment, and the Print Transducer(s) Adjustment according to the Adjustment Procedures.

- 3 Remove the secondary control panel cover. Remove the four bolts securing the main print assembly to the shock mounts in the bottom of the print cavity.

Note: Some printers have a small piece of 0.005 shim stock at each end of the front rail guide. Recover these shims when removing the rail.

- 4 Loosen the two clamp screws securing the front guide rail to the end plates. Lift the print assembly far enough out of the print cavity so that the front guide rail will slide to the left and out of the carriage bearings.

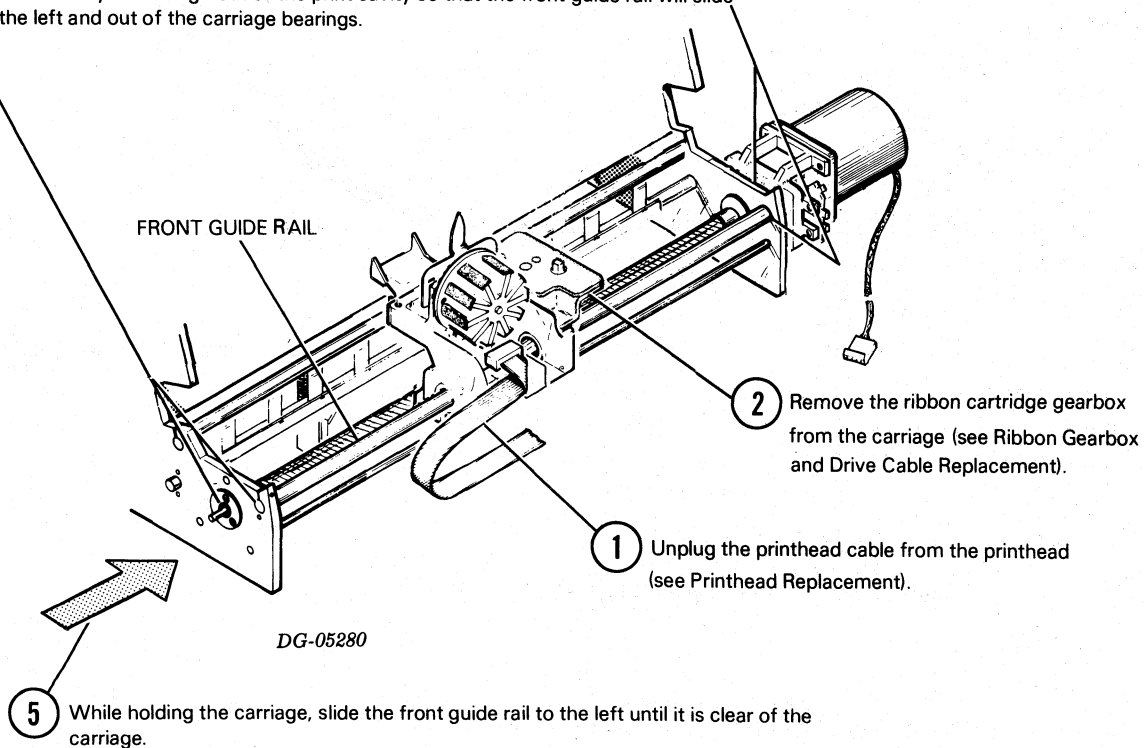

DG-05280

Figure 15.8 Carriage Rail and Bearings Replacement

REPLACEMENT PROCEDURES

- 9 Place the carriage in position on the rear guide rail and slide the front guide rail in from the left through the bearings. Reinstall any shims removed in Step 4.

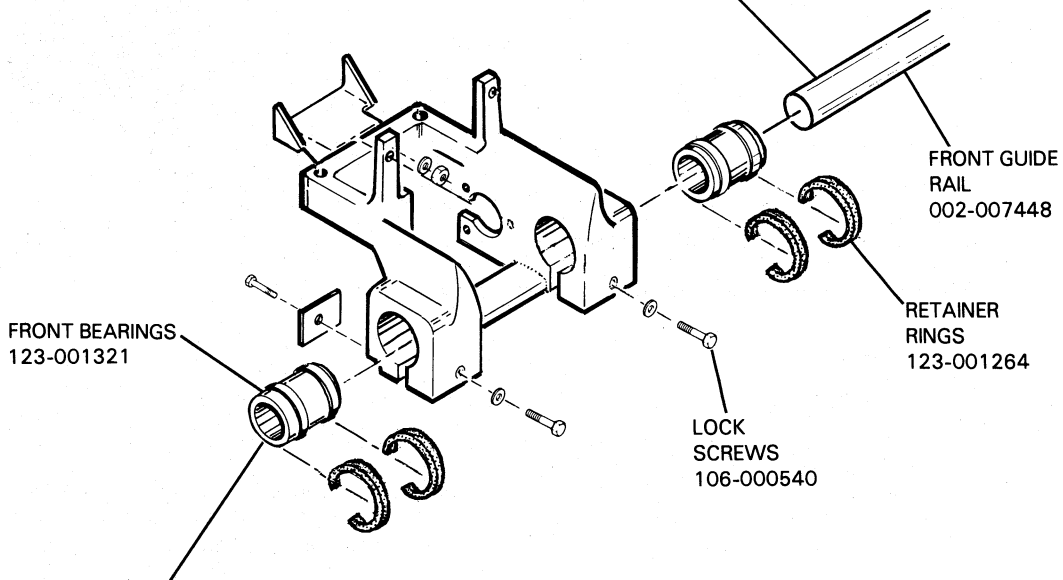

- 6 Remove the two front bearings by loosening the lock screws and unsnapping the retainer rings.
- 7 Secure the new front bearings in the carriage by snapping their retainer rings in place.
- 8 Clean the front guide rail and grease the bearings (see Carriage Bearings Cleaning and Adjustment).

- 10 Adjust the two carriage bearings as described in Carriage Bearings Cleaning and Adjustment.
- 11 Replace the gearbox (see Ribbon Cartridge Gearbox and Cable Drive Replacement).
- 12 Replace the printhead cable (see Printhead Replacement) and secondary control panel cover.

- 1 Remove the paper feed motor (see Paper Feed Motor Replacement), and the secondary control panel (See Control Panels and Keyboard Replacement).

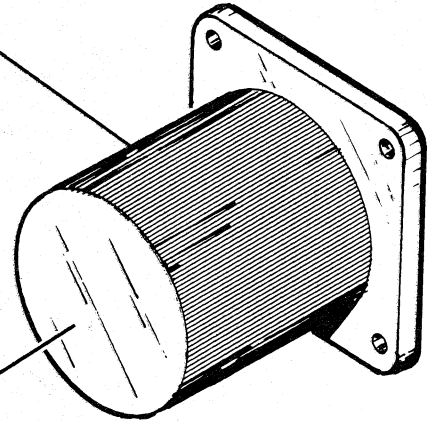

- 13 Install the paper feed motor (see Paper Feed Motor Replacement).

- 14 Perform the Platen Alignment Adjustment according to the Adjustment Procedures.

- 6 Lift the platen up and back, out of the frame. Move the transducer mounting bar to the new platen. Move the platen slides to the new platen.

Note:
When fastening the guide bars be sure the platen slides smoothly, and has no vertical play.

- 11 Attach the guide bars on top of the platen slides.

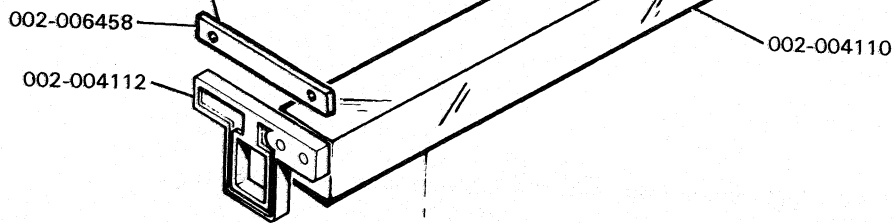

Note:
Be carefull not to damage the Out of Paper Transducer when replacing the platen in the frame.

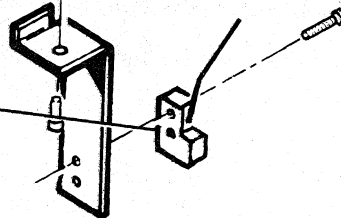

DG-05235

DG-05235

Figure 15.9 Platen Replacement

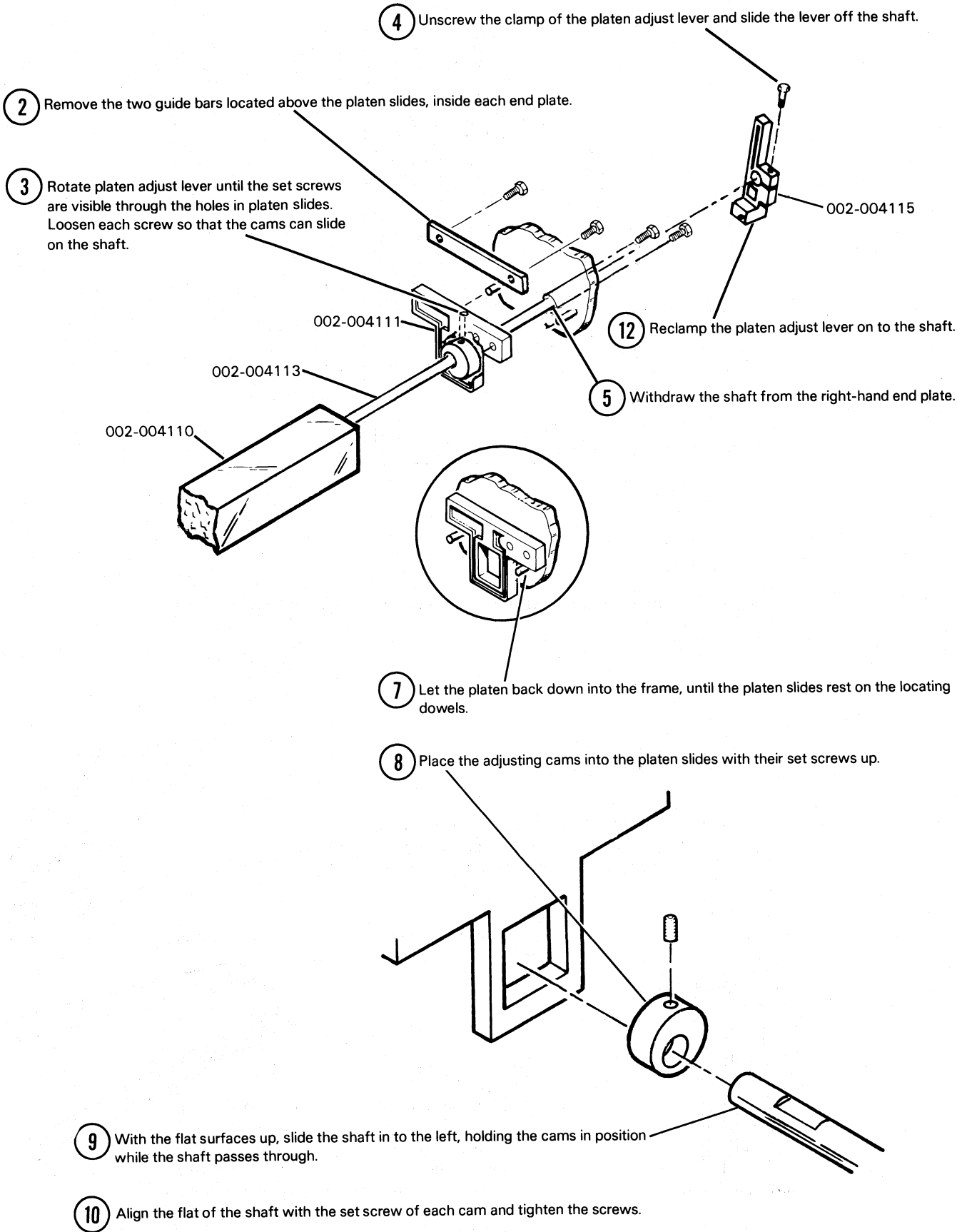

DG-05235

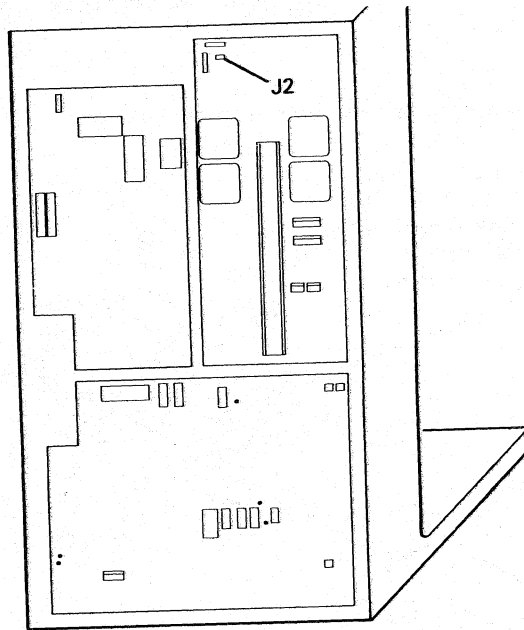

- 4 Loosen the clamp screw of the drive pulley and slide the pulley off the motor shaft.

- 7 Install the drive pulley on the motor shaft so there is 0.015 in. clearance with the end plate and 0.030 in clearance between the gear holder and the clamp.

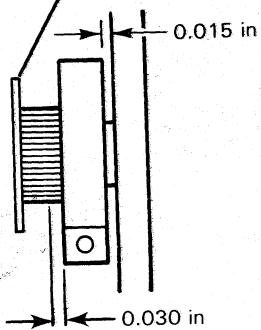

- 2 Remove the drive belt.

- 8 Replace the drive belt on its pulleys. Measure the torque required to rotate the paper feed shaft. Slide the motor back to tighten the belt. The correct belt tension results in an increase in the torque required to rotate the paper feed shaft of 1 to 2 inch oz. over the torque required with the belt removed.

002-004134

002-006551

123-000946

5 Remove the two remaining bolts securing the motor. Pull the motor out from the end plate and lay it down in the printer frame. Unplug the control cable from J 2 on the driver board.

1 Loosen the four motor mounting bolts and slide the motor forward.

005-009508

6 Loosely install the new motor using only the two rear bolts.

9 Install the vertical transducer and mounting bracket. Perform the Vertical Transducer Adjustment.

Note:
After installing the transducer, check to be sure all four motor mounting bolts are tight.

3 Remove the vertical transducer and bracket by unscrewing its two mounting bolts.

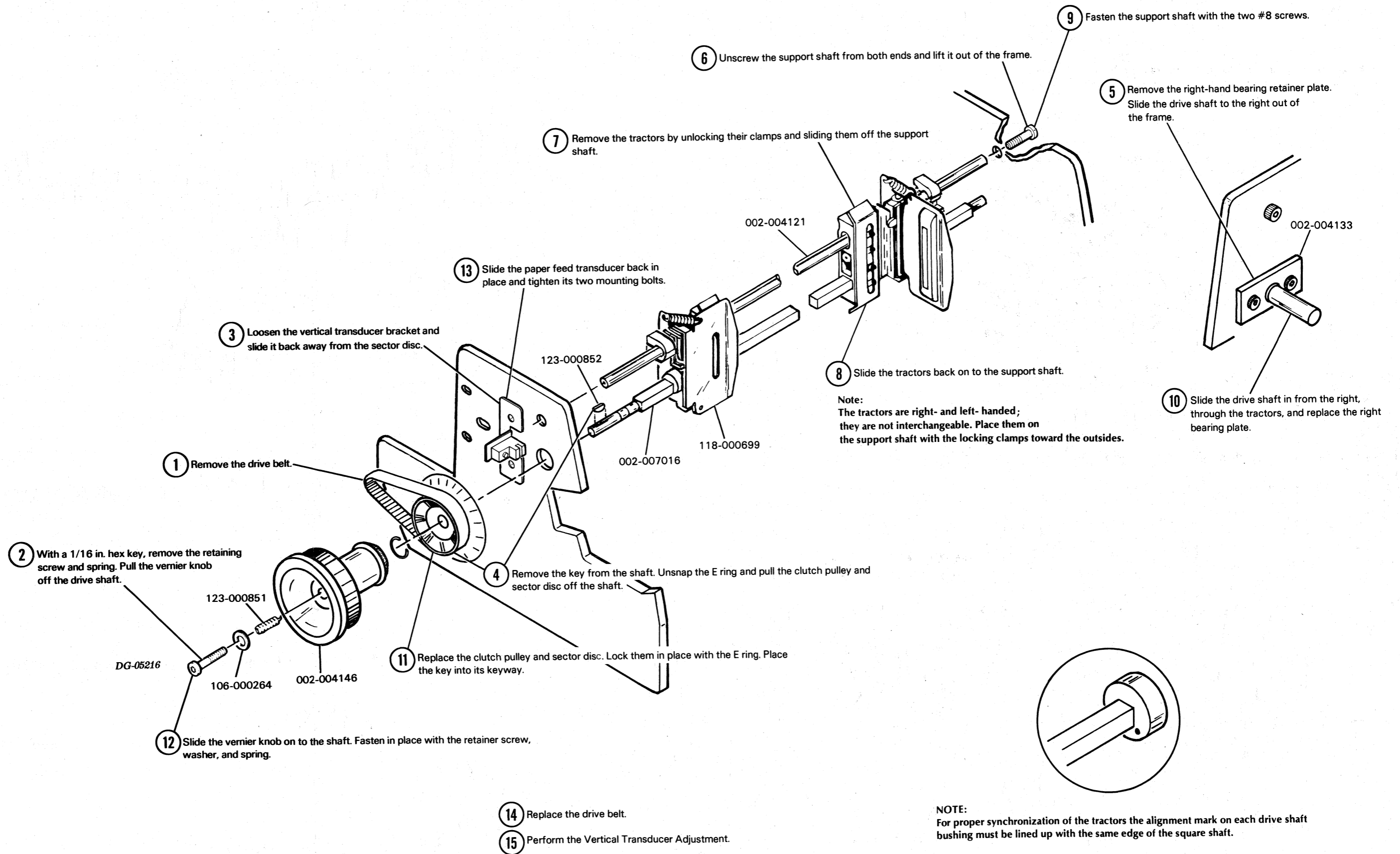

DG-05216

Figure 15.11 Paper Feed Drive Mechanism Replacement

Paper Feed Transducer Replacement

- 1 Unplug the cable connector from J7 on the Driver PC Board and cut any ties securing the cable.
- 2 Remove the transducer from its mounting and install the new transducer.
- 3 Reconnect the cable to J7 and tie it down away from any moving parts.
- 4 Perform the Paper Feed Transducer Adjustment.

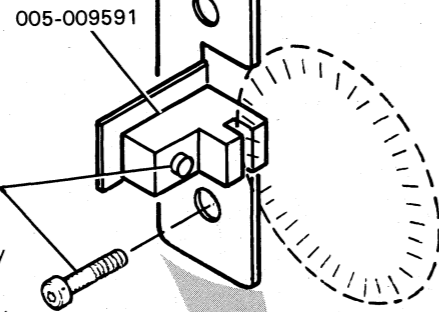

Transducer mounting bar 002-6152
Transducer mount 002-6153

Print Transducer Replacement

- 1 Unplug connector J9 on the Driver PC Board (the Compressed Print transducer cables go to J8) and cut any ties securing the cable.
- 2 Remove the transducer from its mounting and install the new transducer.
- 3 Reconnect the cable to J9 (or J8 for compressed print), and tie it down away from any moving parts.
- 4 Perform the Carriage Sector Disc(s) Timing Adjustment: Parts I and II and the Print Transducer(s) Adjustment.

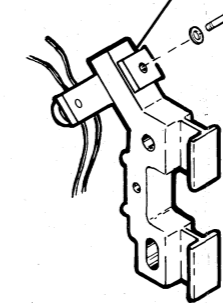

NOTE:
If the printer is equipped with the compressed print option there is an extra pair of transducers. Center transducers on the code discs.

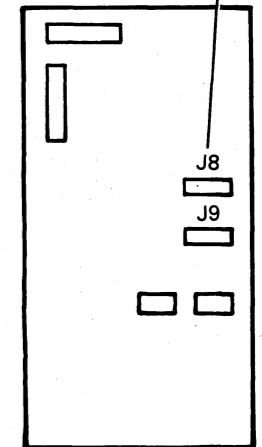

Home Flag Transducer Replacement

- 1 Unplug the cable connector from J6 on the Driver PC Board and cut any ties securing the cable.
- 2 Remove the transducer from its mounting and install a new transducer.
- 3 Reconnect the cable to J6 and tie it down away from any moving parts.
- 4 Perform the Carriage Sector Disc(s) Timing Adjustment: Parts I and II.

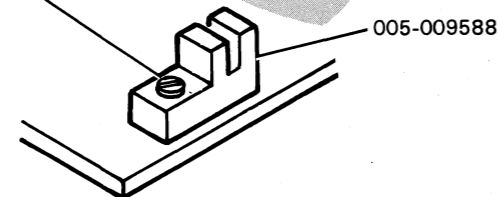

Out of Paper Switch Replacement

- 1 Unplug the cable connector from J24 on the secondary control panel and cut any ties securing the cable.
- 2 Remove the switch from its mounting and install the new switch.
- 3 Reconnect the cable to J24 on the secondary control panel and tie it down away from any moving parts.
- 4 Load paper, power up the printer and see if the Fault Light goes on (it should remain off). Remove the paper with the power on and see if the Fault light comes on (it should). Bend the arm of the switch slightly until it operates properly.

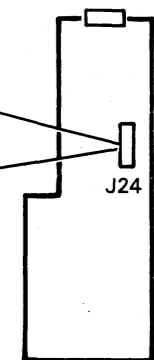
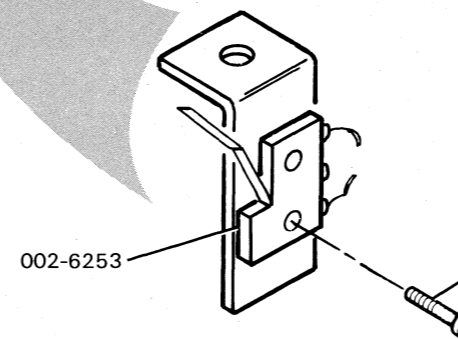

DG-06173

Figure 15.12 Transducers Replacement

1. Remove the power supply board and the control logic board.
2. Unplug the fan power cable at the fan housing.
3. Remove the four bolts securing the fan to the cabinet.

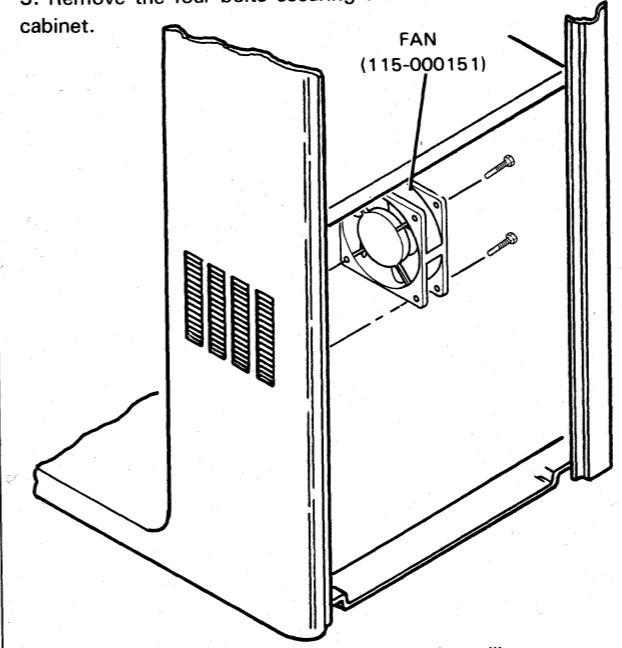

4. Install the new fan, making sure that the fan will blow air into the cabinet.
5. Reconnect the fan power cable.
6. Reinstall the power supply board and the control logic board.

DG-06174

Figure 15.13 Fan Replacement

Chapter 16
ADJUSTMENT PROCEDURES

TOOLS REQUIRED:

accurate volt meter

- 1 Attach the positive lead of the volt meter to TP4 (or positive lead of C12). Attach the negative lead to TP3 (or negative lead of C12).

SPECIAL NOTES:

This adjustment should be performed before any other adjustment.

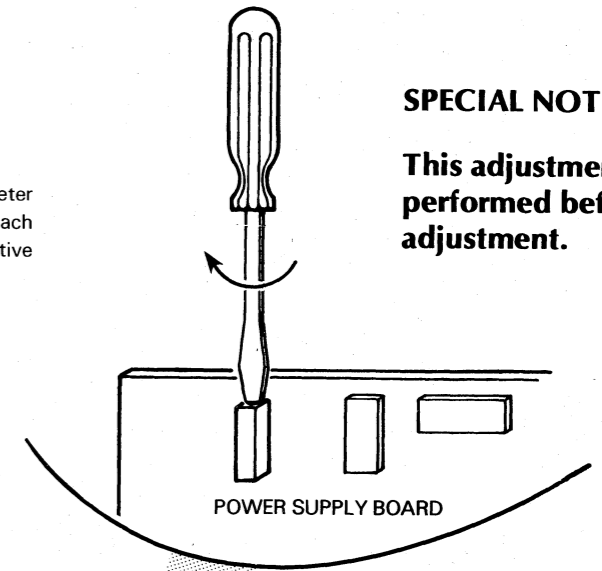

PIN	SIGNAL
1	-12V
2	-5V
3	POWER OK
4	GND
5	+5V
6	+14V

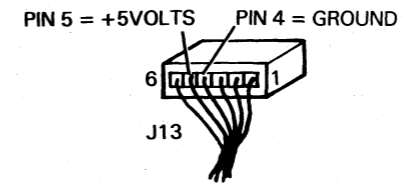

- 2 Turn on the printer. Without the printer printing, adjust the 10-turn potentiometer on the power supply board until the volt meter reads +5.0 volts, + 0.1 volts, 0.0 volts.

TP4=+5VOLTS
TP3=GND

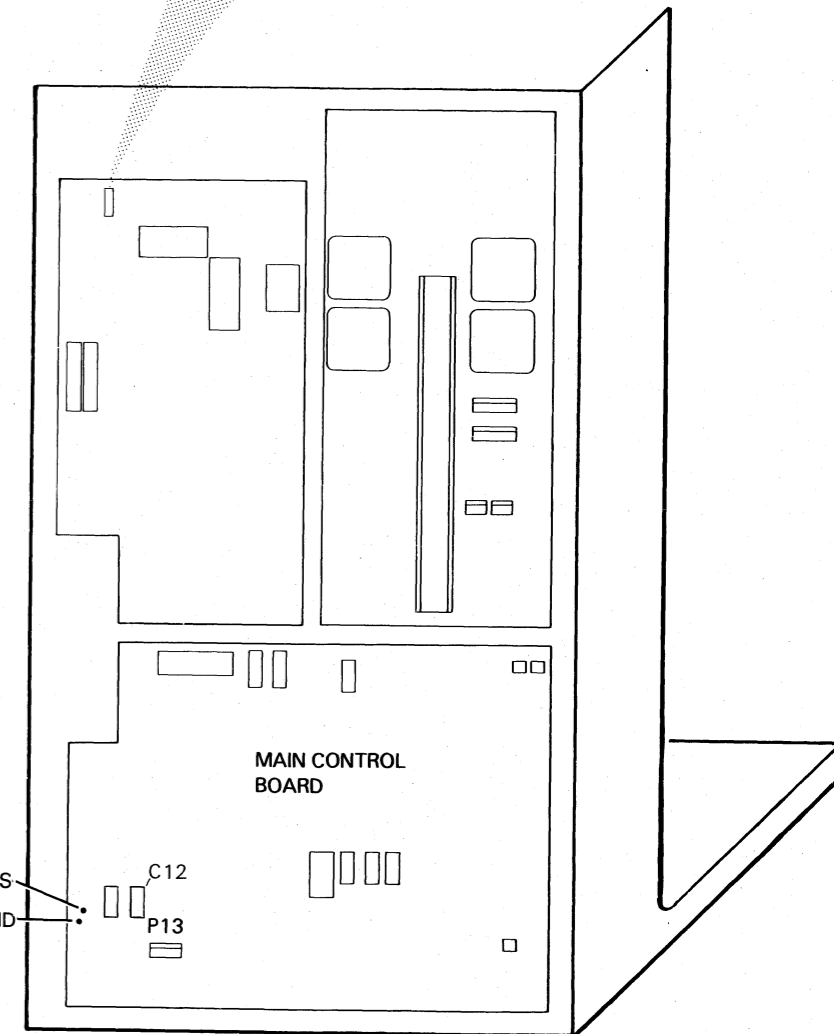

DG-06175

Figure 16.1 Power Supply 5 Volt Adjustment

OPTIONAL SETUP PROCEDURE USING
P-MAT TEST UNIT

- 1 Set up your oscilloscope as follows - positive edge trigger - 0.2 ms div-50 volts div.
- 2 Attach the probe to either of the two left-hand heatsinks on the driver board. Attach the ground clip to the negative lead of either capacitor C5 or C6.

- 3 While offline, place the NORM/COMP switch in the NORM position, press the TEST/ESC DISABLE switch towards TEST, and place the printer on line.
- 4 Adjust R41 on the main control board so that the distance from rising edge to rising edge of the trace shown below is 1.85ms.

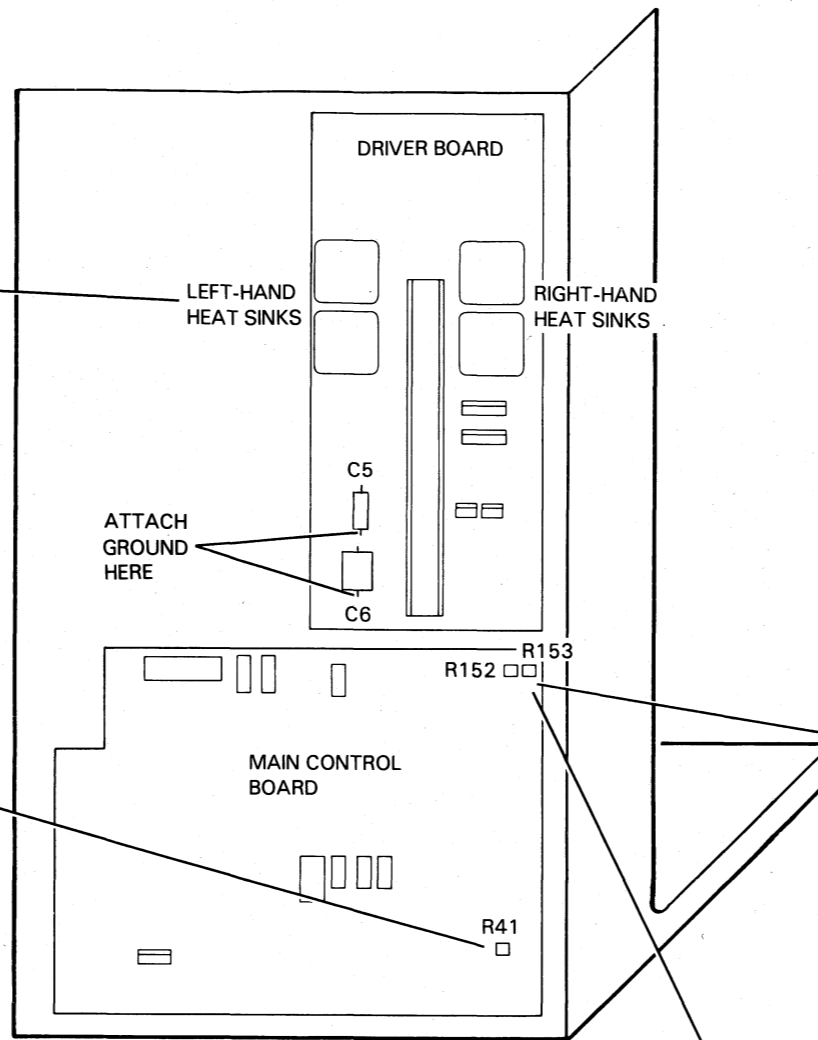
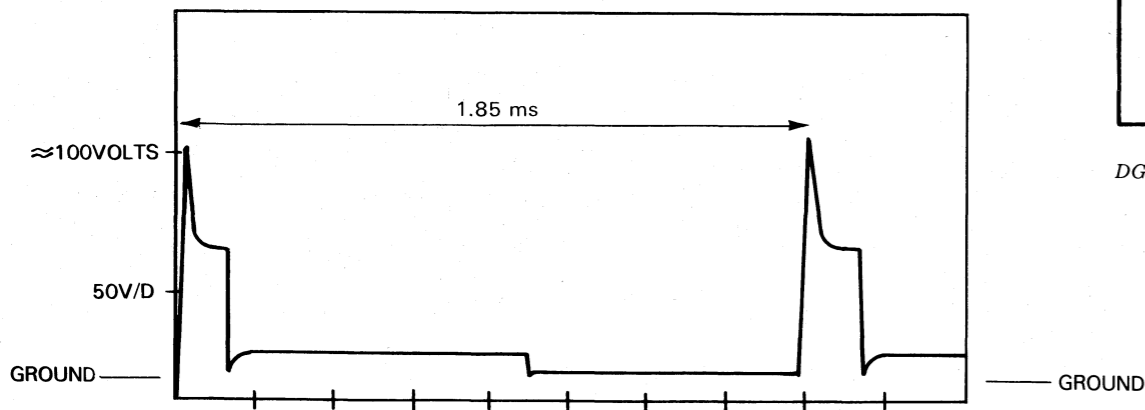

- A Attach Channel A of P-MAT to TP11 on 005-13777 logic board on U68, pin 4 on 005-9503 logic board.
- B Set Channel A ARMED switch to
- C Set SAMPLE RATE switch to .01 SEC.
- D Execute self test.
- E Adjust R153 until P-MAT reads approx. 1850 while carriage is in motion (readings will vary while carriage reverses direction).
- F Attach Channel A probe to TP14 (U82, pin 9 on 005-9503 logic board).
- G Set Channel A ARMED switch to
- H Set FUNCTION switch to PULSE WIDTH
- I Adjust R152 until display indicates approx. 1000.

- 5 Change the oscilloscope to a time base of 20μs/div.
- 6 Adjust R152 until the distance from the primary peak in the signal to the falling edge as shown below is 100μs.

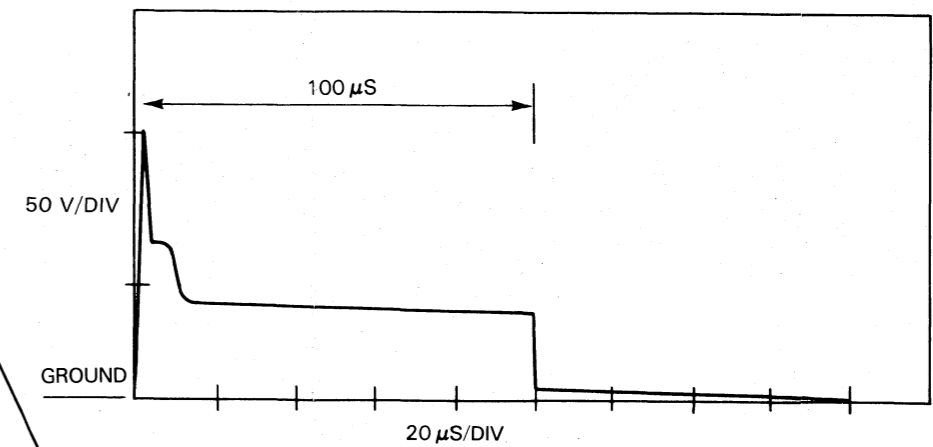

- 7 Place the oscilloscope probe on either of the right-hand heatsinks on the driver board and adjust R153 in the same manor.
- 8 Depress the MST RST switch to terminate self-test.

PART I - ROUGH ADJUSTMENT

- 1 Turn off the printer. Remove the side cover exposing the main control board, power supply, and driver board. Disconnect J1 on the driver PC board.
- 2 Connect the oscilloscope probe to TP9 (or pin 14 of U34) on the main control board. Connect the ground clip to TP3 (or pin 8 of U34).

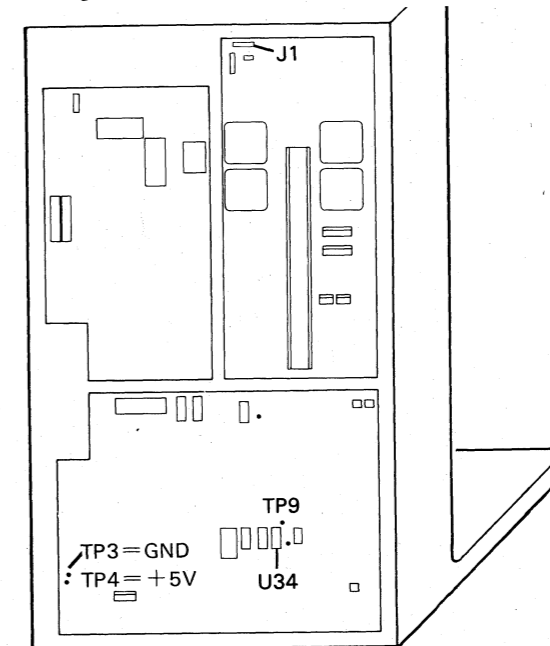

DG-05218

- 3 Turn on the printer. Move the print carriage to within a few inches of the left margin. Now, slowly move the carriage to the left until the signal on the oscilloscope makes a high to low transition (Fine tune the carriage position if you pass the actual transition point).

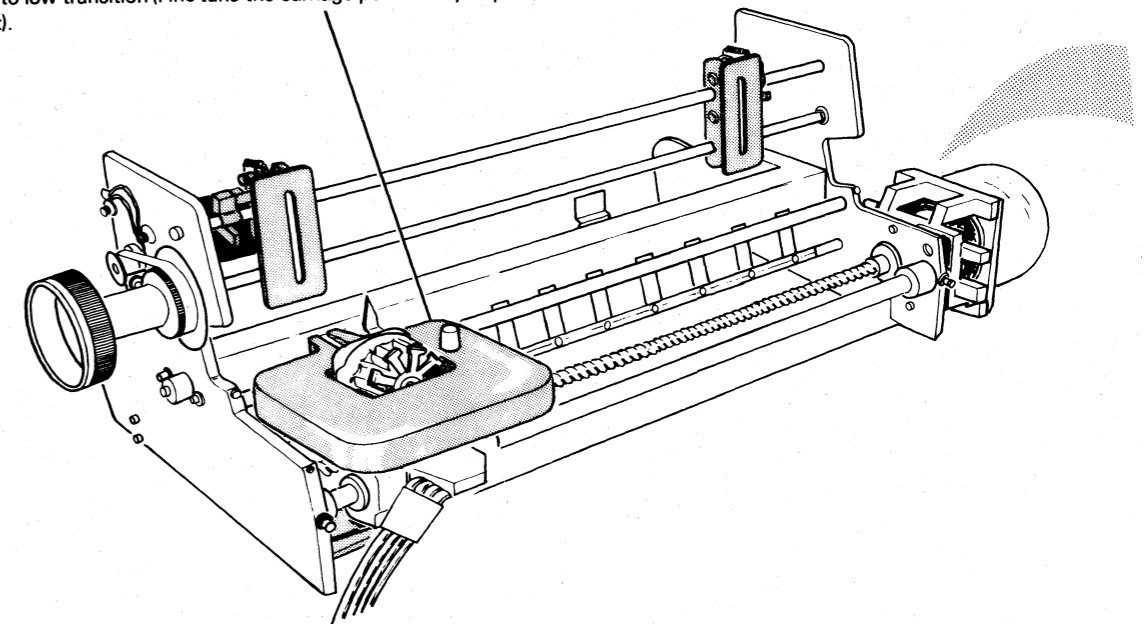

DG-06177

Figure 16.3 Carriage Sector Disc(s) Timing Adjustment, Part I

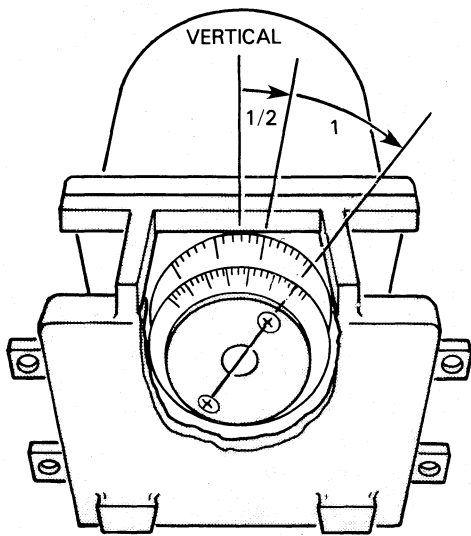

- 4 The timing disc nearest the motor (if there are two) should be positioned as illustrated below. If the position is correct, proceed to PART II.

- 6 Starting with the timing disc(s) positioned as shown below, rotate them clockwise to the position shown under step 4. Do not turn the motor drive shaft when rotating the disc(s).

- 5 Loosen the screw which secures the timing disc(s) to the motor shaft. Reposition the carriage as described in step 3.

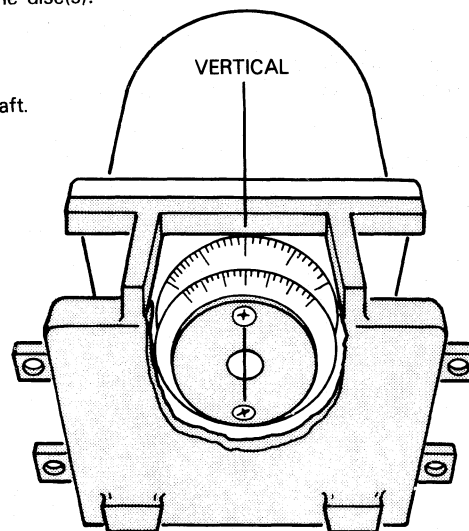
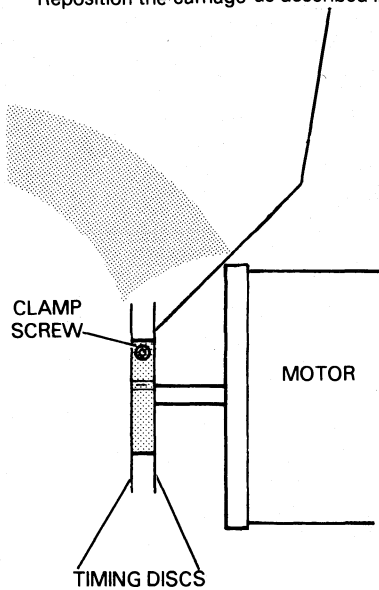

- 7 Make sure the sector disc(s) are not touching the sides of any of the transducers. Tighten the clamp screw which secures the disc(s) to the motor shaft. Turn off the printer and reconnect the carriage motor control cable to J1 on the driver PC board.

4

ADJUSTMENT PROCEDURES

PART II - FINE ADJUSTMENT

- 1 Set up your oscilloscope as follows: Attach channel A of the oscilloscope to TP9 (or pin 14 of U34, HOME). Trigger on a negative edge. Attach channel B to TP10 (or pin 8 of U35, START CHAR). Attach the ground clip to TP3 (or pin 8 of U34). Set the sweep rate to .5ms/div. Set the voltage range to 1 volt/div.

NOTE: If P-MAT test set is available, substitute the P-MAT alignment procedures for first 3 steps of this procedure.

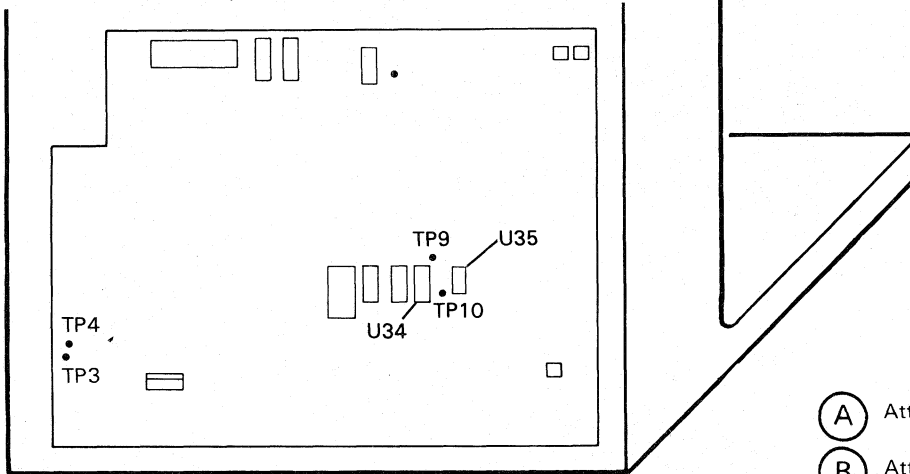

OPTIONAL ADJUSTMENT PROCEDURE FOR P-MAT TEST SET

- A Attach Channel A probe to TP9 (U34, pin 8).
- B Attach Channel B probe to TP10 (U35, pin 8).
- C Set Channel A ARMED switch to
- D Set Channel B ARMED switch to
- E Set FUNCTION switch to TI.
- F Set SAMPLE RATE switch to 10 SEC.
- G Display should indicate $2.8 \pm .1$ (NORMAL mode) or 3.8 ± 0.7 (COMPRESSED mode)
- H Complete the remainder of the adjustment procedures beginning with step 4.

- 2 Turn on the printer. Place the NORM/COMP switch in the NORM position. While offline, press the TEST/ESC DISABLE switch towards TEST and place the printer online.
- 3 The oscilloscope should show this trace.

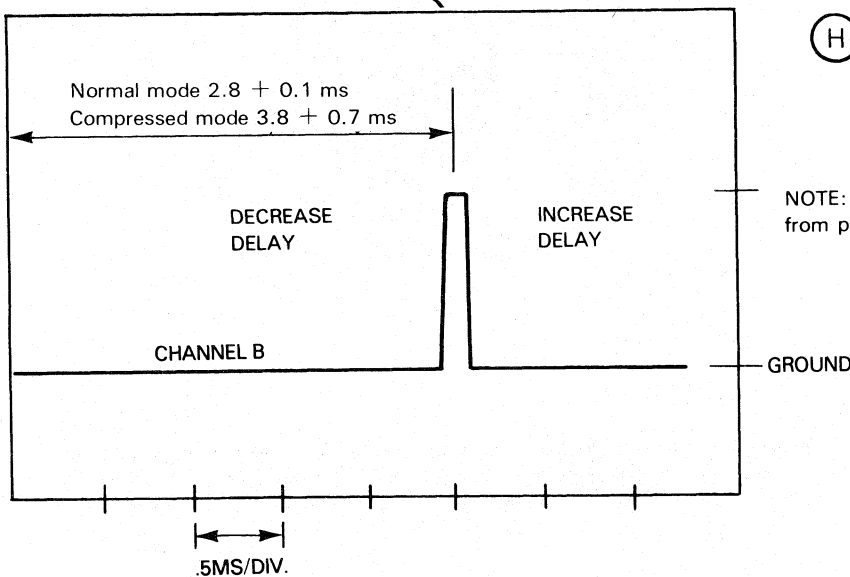

NOTE: Amplitude may vary from printer to printer.

DG-06178

Figure 16.4 Carriage Sector Disc(s) Timing Adjustment, Part II

- ④ TO ADJUST: Press the MST RST pushbutton. Loosen the timing disc(s) clamp screw. Rotate the disc(s) assembly in the proper direction as illustrated. Tighten the clamp screw.

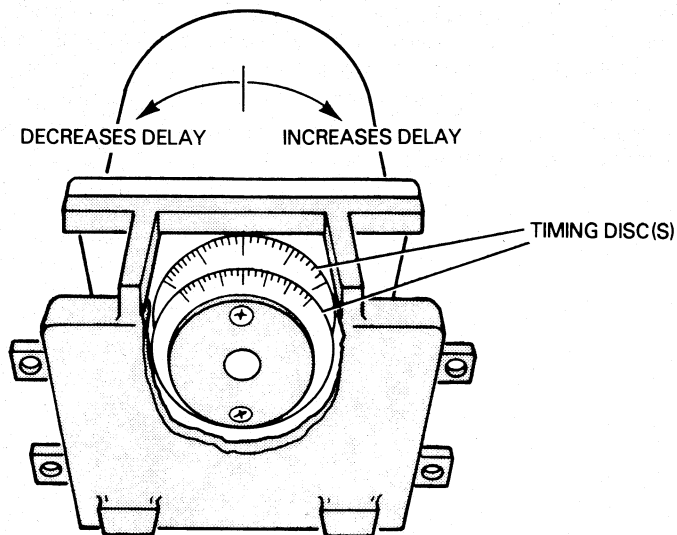

DG-05220

- ⑤ Proceed to step 2 to check the adjustment.
- ⑥ If a compressed disk is installed, compare the oscilloscope trace in normal mode with that in compressed mode and adjust the disks until both traces are about the same.

DG-06178

ADJUSTMENT PROCEDURES

- ① Set up your oscilloscope as follows: Attach channel A of the oscilloscope to TP10 (or pin 8 of U35, START CHAR). Trigger on a negative edge. Set channel A to .2v/div. Attach channel B to TP7 (or pin 9 of U87, PRINT TIME). Set channel B to 2 volts/div. Set the sweep rate to .1mSec/div. Place the NORM/COMP switch in the NORM position.
- ② While offline, press the TEST/ESC DISABLE switch towards TEST and place the printer online.
- ③ The trace should appear in the same place regardless of which direction the printhead is traveling. If the transducer is out of adjustment, the trace will move to the left or right each time the printhead changes direction.
- ④ TO ADJUST: Place printer OFFLINE. Loosen the screw securing the normal print transducer (the upper transducer towards the back of the printer) to the motor mount and move the it up or down. Tighten the screw.

CAUTION:

Make sure you do not cock the transducer; keep it lined up with the disk.

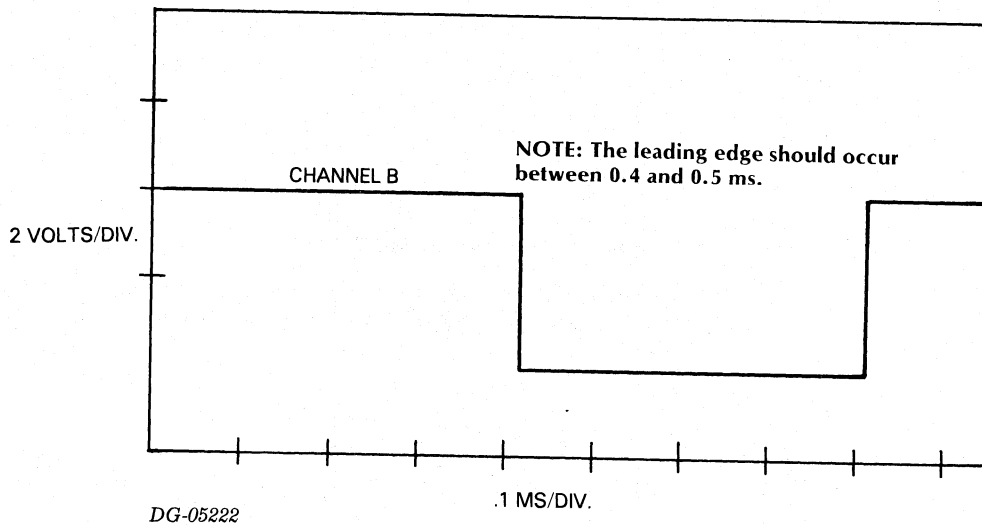

DG-05222

Figure 16.5 Print Transducer(s) Adjustment

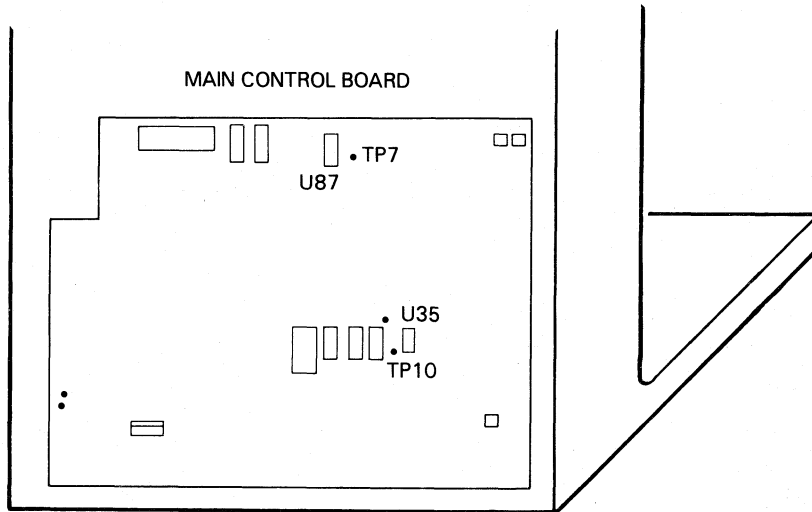

DG-05218

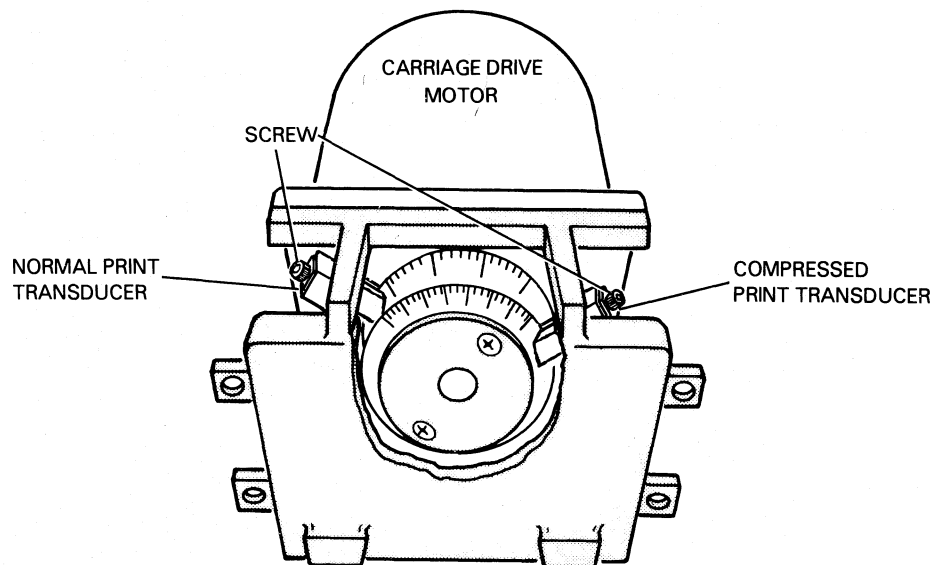

DG-05220

- 5 Repeat step 2.
- 6 IF THE COMPRESSED PRINT OPTION IS INSTALLED: Press the MST RST pushbutton. Place the NORM/COMP switch in the COMP position.
- 7 Proceed to step 2 but this time adjust the compressed print transducer (if necessary). (The compressed print transducer is the upper transducer towards the front of the printer).
- 8 Press MST RST to exit from the self test program.

ADJUSTMENT PROCEDURES

- 1 Verify the correct paper feed belt tension as indicated on page 15-15 (Step 8).
- 2 Attach channel A of your oscilloscope probe to J7 pin 1 (the blue wire) on the driver board. Set channel A's voltage range to 2 volts/div. Set the sweep rate to 2ms/div.

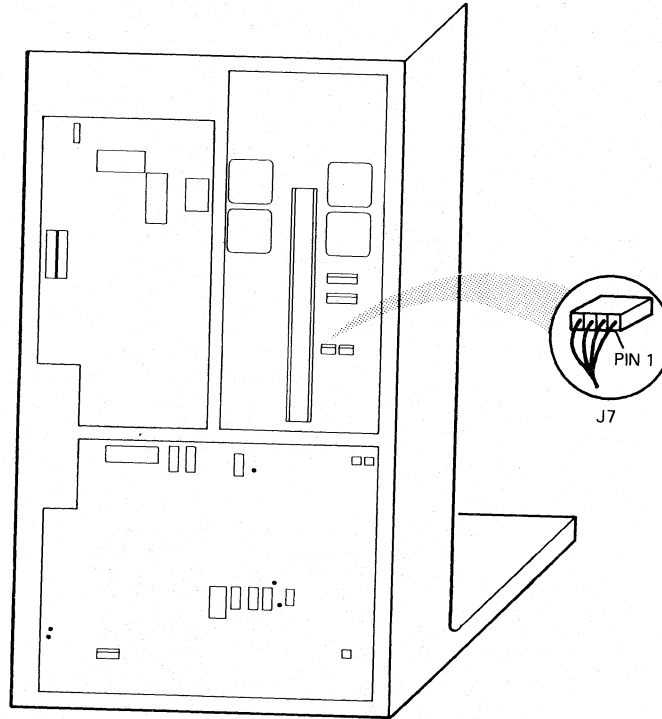

DG-05218

- 3 Remove any paper from the tractors; however, leave the paper in the printer so that the Out of Forms switch does not cause a fault condition. Turn on the printer.
- 4 Press the form feed switch. You should see the following trace on the oscilloscope. The trace may not be exactly symmetrical. Adjust the transducer mounting plate's position to obtain the largest amplitude.

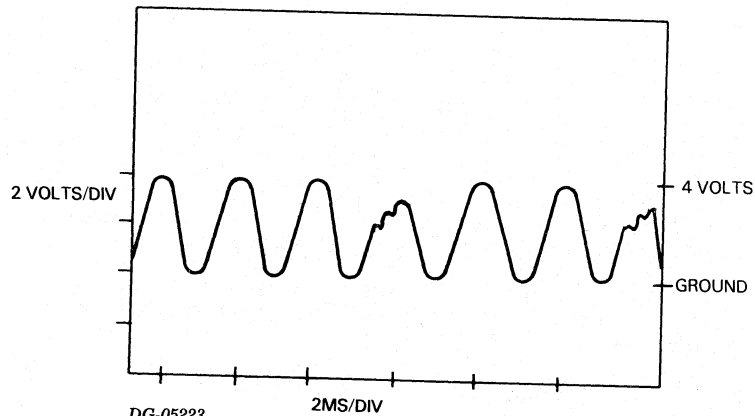

DG-06179

DG-05223

2MS/DIV

Figure 16.6 Vertical Transducer Adjustment

5 If the signal is distorted, does not appear, or the fault light comes on, adjust the vertical transducer as follows:

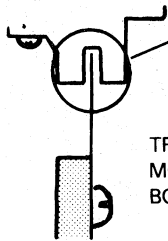

TRANSDUCER MOUNTING BOLT

- Center the horns of the transducer around the slotted sector disc by loosening the transducer's mounting bolt.
- Loosen the two screws attaching the vertical transducer's-mounting plate to the left end plate.
- Move the mounting plate towards or away from the slotted disc and repeat step 3

NOTE:

If the fault light is on, press MST RST before proceeding to step 3.

6 ONCE ADJUSTED - Tighten the two screws which secure the mounting plate to the end plate.

7 Check the tractor shaft for any indication of binding by grasping the square tractor shaft and pushing toward the right side of the printer. Some detectable movement should occur. If not, perform the following:

- Remove the right side tractor shaft bearing plate and Tinsel mounting plate.
- Reassemble the bearing to the shaft, but install the Tinsel mounting tab between the end plate and the bearing plate to permit additional shaft play.

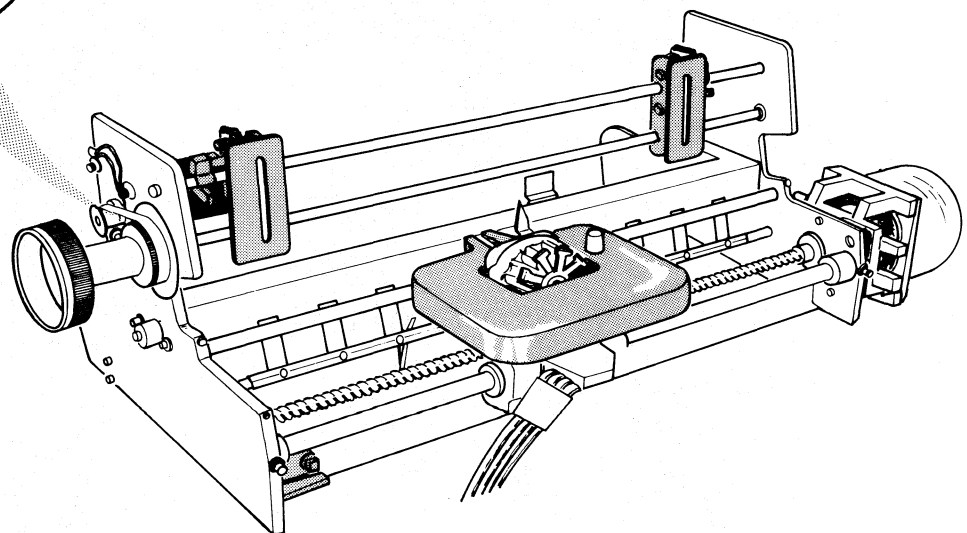
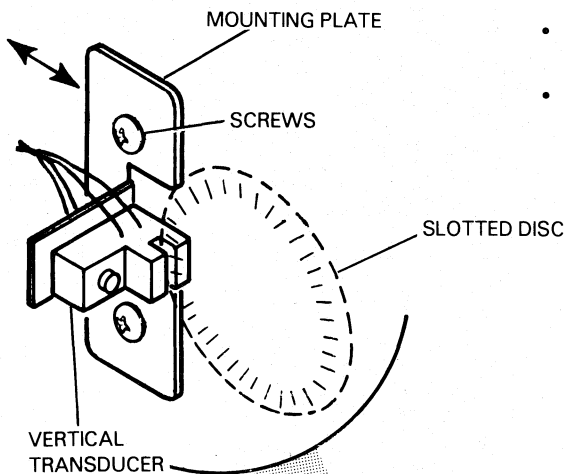

- 1 Remove the carriage from the printer (see Carriage Rail and Bearings Replacement).
- 2 Loosen the two bearing adjustment screws and remove the bearing retaining clips.
- 3 Remove the bearings from the carriage.
- 4 Clear the inside of the bearing using lint-free cloth (no alcohol).
- 5 Apply a small amount of grease to each bearing (grease part no. 120-753).
- 6 Reinstall the bearings and retaining clips on the carriage.
- 7 Clean the front carriage rail using isopropyl alcohol on a lint free cloth. Coat the entire rail with a film of grease (this prevents rusting).
- 9 Install the carriage and carriage rail in the printer (see Carriage Rail and Bearings Replacement). Reinstall the shims if present during disassembly.
- 10 Repeat this step for the right bearing.
- 8 Attach the torque watch to the bearing bar. Then install the bearing bar in the carriage, holding the bar in the vertical position. Rotate the bar and tighten the adjustment screw until an increase in torque of 1 to 1.5 inch oz. is noted. Repeat for the other bearing.

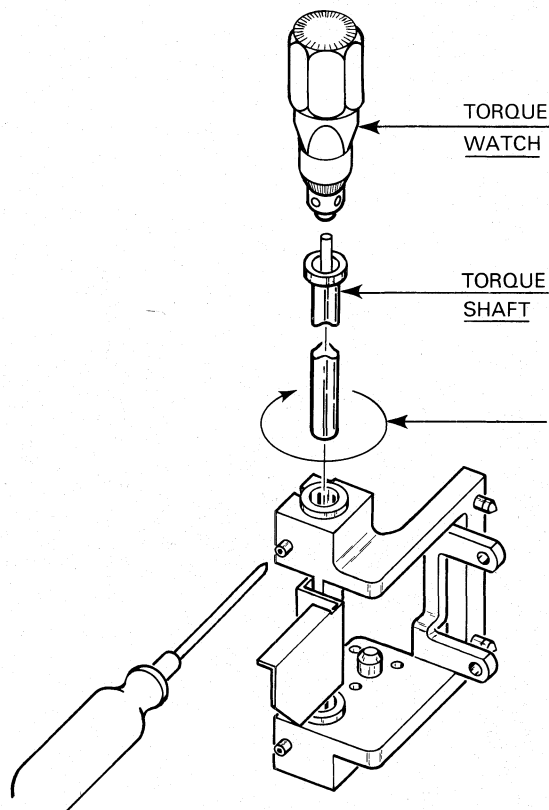
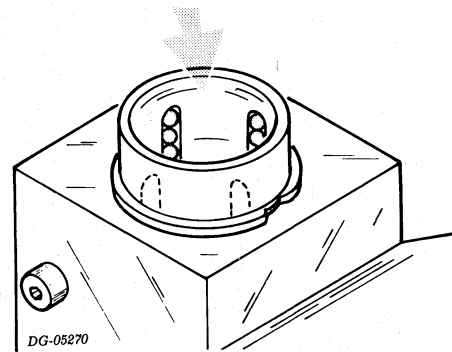

NOTE: To set preload - with clamp screw loose take a torque reading while holding vertical. Begin to tighten screw while rotating the torque watch. As soon as an increase of 1 to 1 1/2 inches oz. of torque is detected, Stop adjustment. Invert and set the opposite bearing.

DG-05270

Figure 16.7 Carriage Bearings Cleaning And Adjustment

NOTE:
When installing the front carriage rail,
be sure you place one rubber stop on
the left end and two rubber stops on
the right.

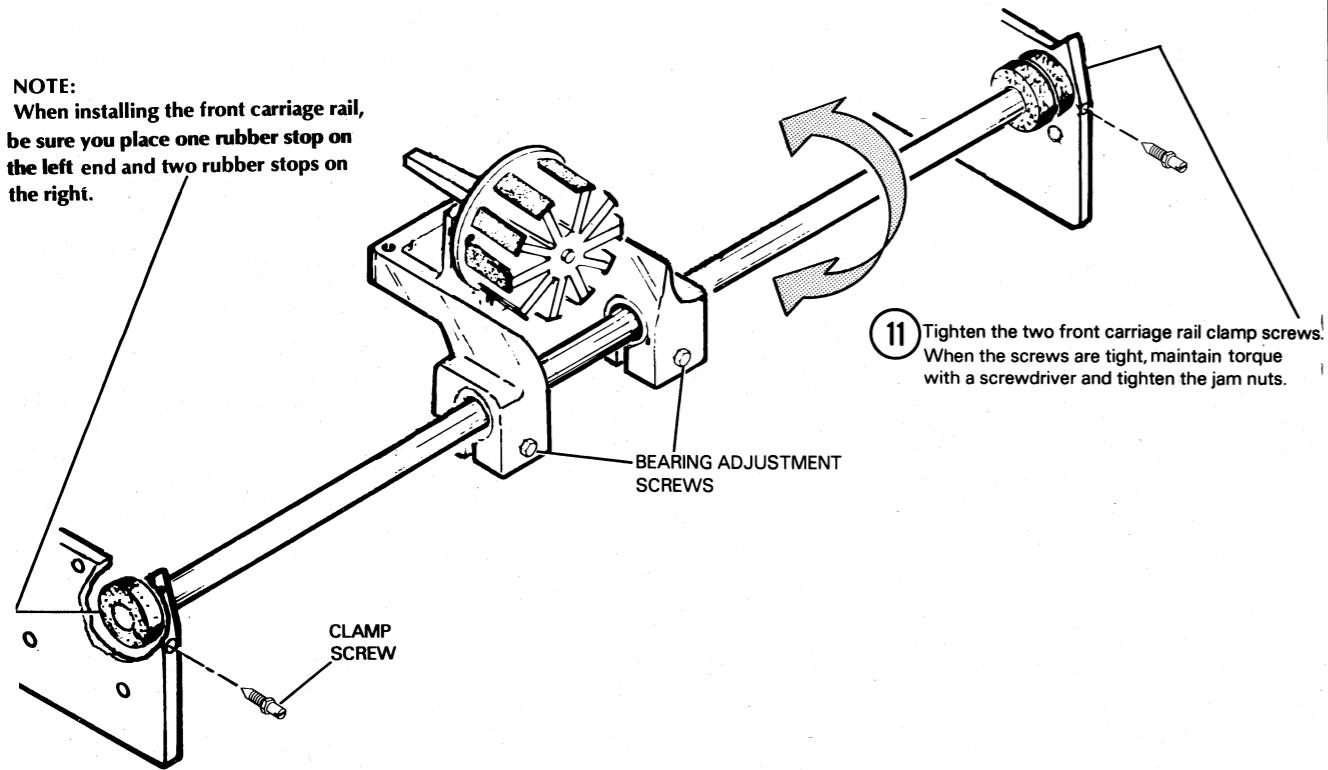

12 Replace the carriage motor assembly, gearbox, and secondary control panel (see Carriage Rail and Bearings Replacement).

13 Perform the Carriage Sector Disc(s) Timing Adjustments (Parts I and II).

4

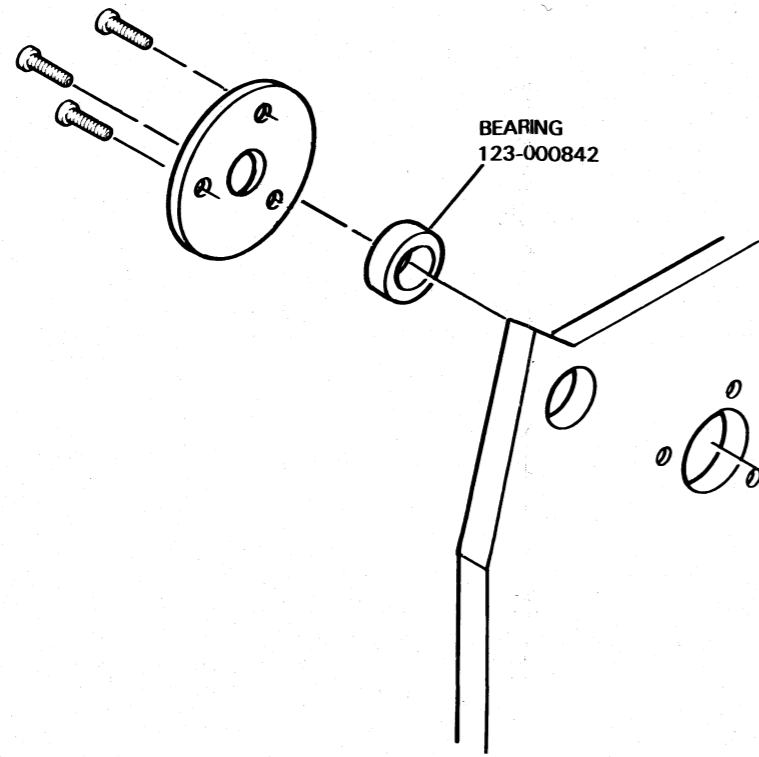

BEARING
123-000842

SHIMS
123-000992
(as required)

NOTE:
This adjustment procedure is meant to be performed between steps 6 and 10 of Anti-backlash Nut and Leadscrew Replacement.

NOTE:
When fastening the bearing retainer plates be sure they are flush with the end plate, and that the washers are not wedged between the retainer plate and the end plate.

2 If there IS EXCESSIVE MOTION: Remove the left bearing retainer plate and INSERT one additional shim on the left end of the leadscrew. Refasten the left retainer plate and repeat steps 1 and 2.

If there is NO MOTION, or the leadscrew does NOT TURN: Remove the left bearing retainer plate and REMOVE one of the shims from the left end of the leadscrew. Refasten the left retainer plate. Check that the leadscrew moves properly.

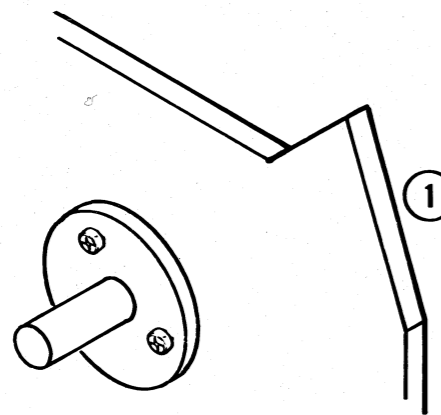

1 Press in on the left end of the leadscrew with about 5 lbs. of pressure and note whether or not the leadscrew moves.

NOTE:
Displacement should be between .002 and .010 inches. Each shim washer is .004 inches thick.

DG-05225

SPECIFICATIONS:

Displacement should be between .002 and .010 inches. Each shim washer is .004 inches in thickness.

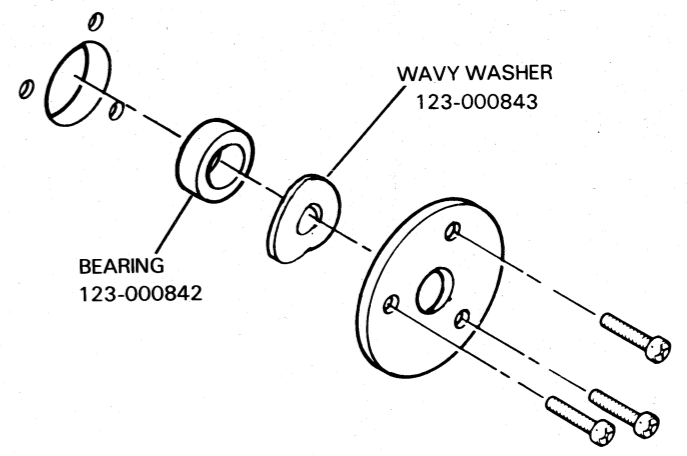

WAVY WASHER
123-000843

BEARING
123-000842

DG-05225

Figure 16.8 Leadscrew Preload Adjustment

ADJUSTMENT PROCEDURES

Horizontal Motion Check

- 1 Check carriage float with lead screw nut, horizontal stepper motor and ribbon drive assembly disconnected.
- 2 Move carriage from margin to margin using a tensionmeter (part number 128-787). A normal reading is 6 to 8 (i.e., approximately 180 gram force).
- 3 If the reading changes at either end of the carriage rail, the front bearing must be shimmed using the following procedure.
 - Loosen screws that retain the front bearing bar.
 - Insert a small piece of 0.005 inch shim stock (part number 002-8288) in holes in both end plates so that the front bearing bar is moved away from the platen. Do not permit any of the shim stock to protrude outside of the end plates.
 - Tighten the bearing bar retaining screws snugly, but do not overtighten.
 - Check platen gap and readjust if necessary

Antibacklash Nut Adjustment

The following procedure allows the backlash nut to correctly align with the carriage.

- 1 Remove the screws that secure the nut to the carriage. Discard the lock washers.
- 2 Install the cap screws using a flat washer (part number 106-687), but do not tighten the screws.
- 3 If the reading changes at either end of the carriage rail, the front bearing must be shimmed using the following procedure.
- 4 Move the carriage to both ends of the travel and tighten the screws 1/8 turn (in clockwise sequence). Continue moving the carriage and tightening the screws 1/8 turn until all the screws are tight.

ADJUSTMENT PROCEDURES

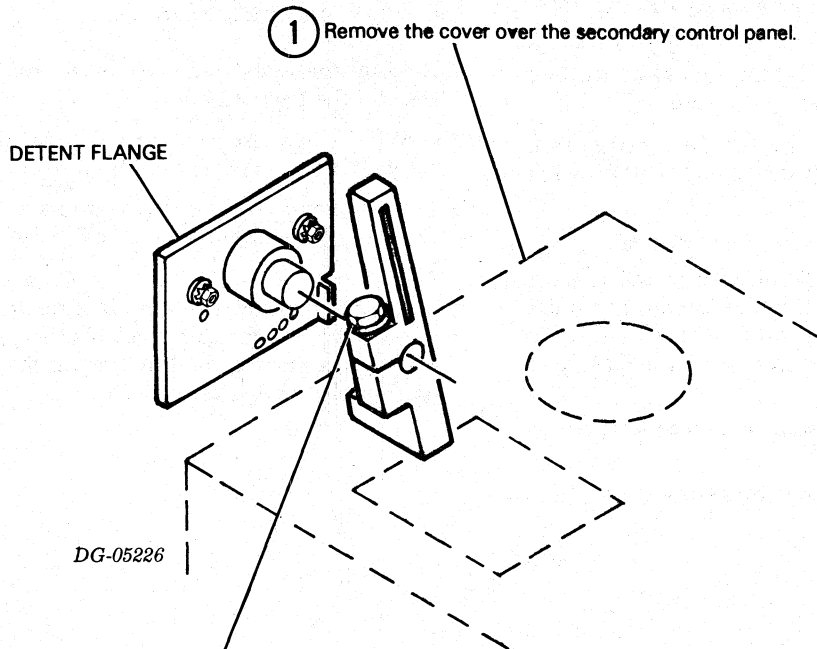

2 Loosen the clamp of the platen adjust lever. Slide the lever out to the end of the shaft and retighten the clamp.

3 Rotate the lever until the cams are in position as shown. The set screw and the largest point of the cam face the front of the printer and are pointed just above the horizontal.

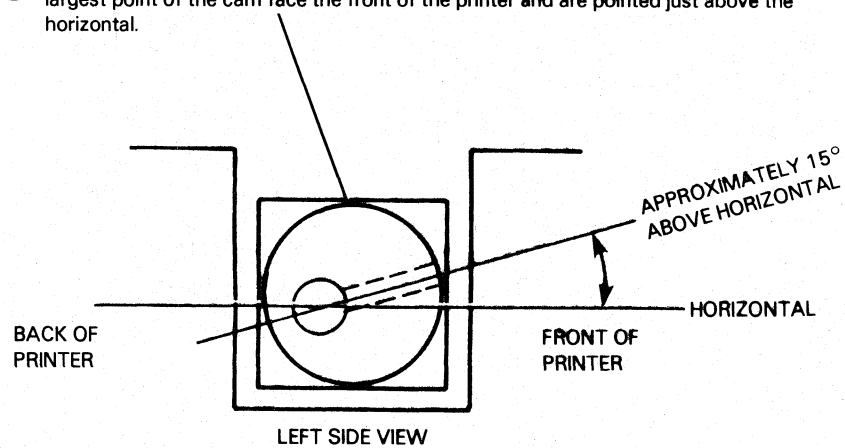

DG-06180

Figure 16.9 Platen Alignment Adjustment

- 4 While holding the platen still, loosen the clamp of the platen adjust lever. Position the lever so that the detent pin is in the #1 hole (the lever in the full forward position). Tighten the clamp screw. When the platen cam is properly adjusted, all the paper fingers should touch the platen with the lever in position 1, and all the fingers should be off with the lever in position 3.

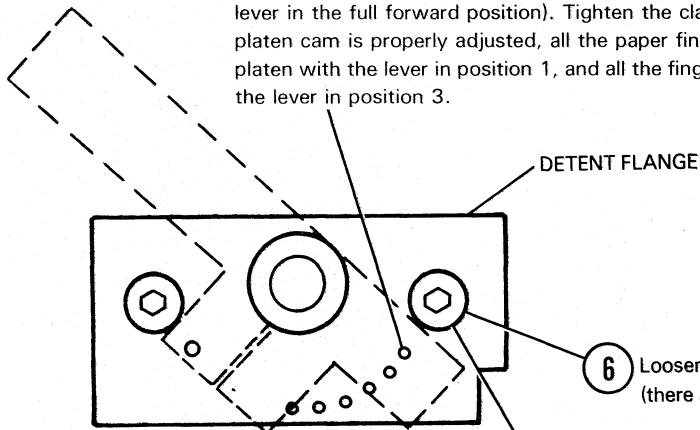

- 6 Loosen the four screws securing the two detent flanges (there are two screws on each side).

- 5 Move the carriage all the way to the left.

- 10 When the gap spacing is uniform (0.020 in.) at both ends tighten the four screws securing the detent flanges.

Note:
The Printhead is very sensitive. Be careful not to damage the Printhead while measuring the platen spacing.

- 7 Set the gap between the printhead and the platen to 0.020 ± 0.001 inches. Measure the gap using an .020 feeler gauge. Adjust the platen by sliding the detent flanges forwards or backwards.

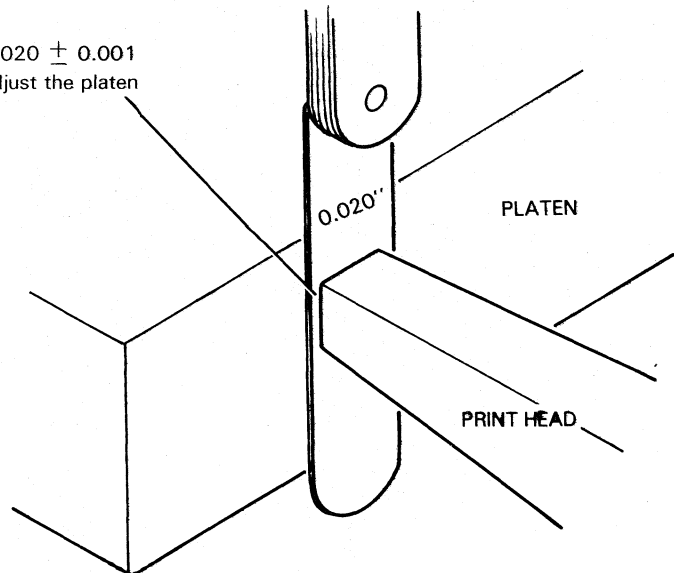

- 8 Move the carriage all the way to the right and repeat step 7.

- 9 Move the carriage back to the left and check the gap spacing.

ADJUSTMENT PROCEDURES

Rear Bearing Clearance Adjustment

1 Adjust the platen gap to $0.020 + 0.001$ inch, using the procedure described on fiche 015-000089-EE, 043-001600, dated 07/10/79, page 23.

2 With the platen space lever in position 1, measure the gap between the platen and the rear bearing (item 9 on page III-24 in IPB 016-647). The clearance should be $0.030 + 0.005$ inch. If not, adjust the clearance as follows.

- Remove the print head
- Remove the mounting screws holding the left end of the mechanism to the cabinet.
- Loosen the screws holding the rear rail, and remove the rear rail by sliding it out to the left.
- Set the platen space lever to position 6. Move the carriage to the center of the printer. Tilt the rear bearing and the printhead up. Remove the screw and nut holding the rear bearing in place.

- Remove the rear bearing by tilting the carriage up and sliding the rear bearing out of the carriage.
- File enough material from the rear bearing to meet the 0.030 inch clearance.
- Reassemble the rear bearing to the carriage. Install the rear rail. Push the rear bearing down flat against the rear rail and tighten the retaining screw snugly.

NOTE: Do not overtighten the screw, as the rear bearing may be moved out of parallel with the bearing rail. The correct torque on the screw will allow the rear bearing to be rotated slightly by hand.

- Pull up vertically on the rear bearing using light finger pressure. A noticeable movement of the bearing should occur without movement of the rear rail. If no movement occurs, replace the rear bearing.

ADJUSTMENT PROCEDURES

- ① Move the carriage all the way to the right.

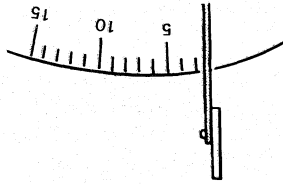

Note:
The scale on the tensiometer begins at "3" and goes up in increments of 1. It is labeled at 5, 10, 15,....etc.

Special Tools Required:

6 inch metal ruler DGC P/N 128-000197

5 M Polyflex tensiometer DGC P/N 128-000787

- ③ Hold the 5M Polyflex tensiometer (DGC P/N 128-000787) with the right hand as shown. The measuring scale should be facing left.

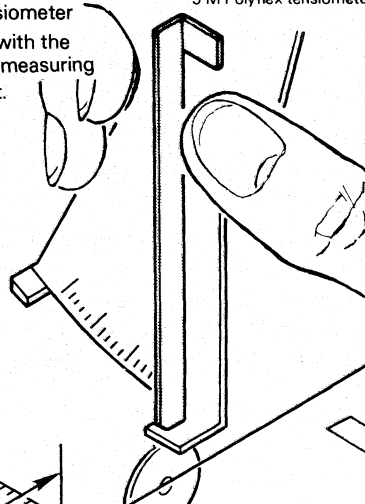

- ② Place a 6 inch metal ruler (DGC P/N 128-000197) underneath the cable about 8 or 9 inches from the left end plate. Orient the ruler with a scale showing 1/4 in. or 1/8 in. divisions facing to the right.

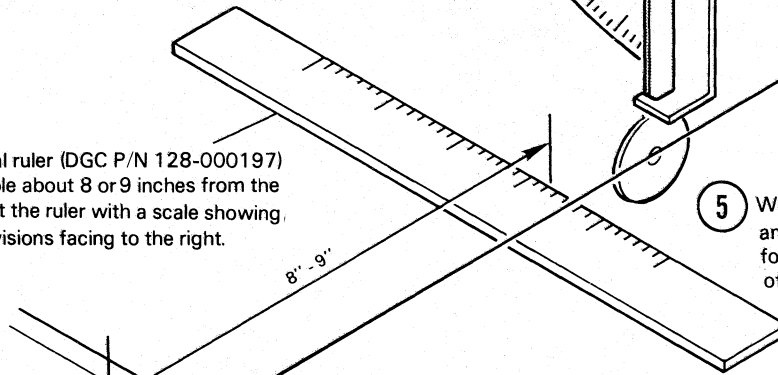

- ⑤ With the tensiometer held vertically, and the scale facing left, pull forward on the cable with the disk of the tensiometer.

- ④ Hold the ruler so that the cable is lined up with a division marking. Note which division.

DG-05227

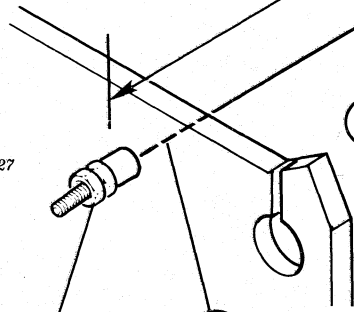

- ⑦ Tighten or loosen the cable if necessary and repeat steps 6 and 7.

- ⑧ When the tension is correct, lock the adjustment by tightening the outer nut without changing the setting.

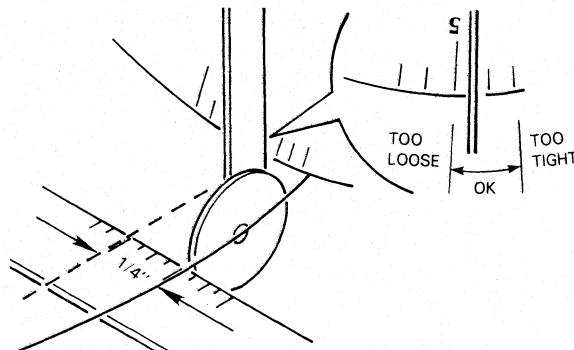

- ⑥ Deflect the cable 1/4 inch from its original position and check the reading on the tensiometer. The arm should cross the scale between "3" and "5".

DG-05227

Figure 16.10 Ribbon Cartridge Drive Cable Adjustment

1. Check to see that all the tension fingers on the paper tension Bar are roughly the same distance from the platen.

2. Bend any tension fingers that are grossly out of line into the correct position.

3. Place the platen in the number 1 (full forward) position.

4. Check to see that all fingers touch the platen.

5. Move the platen lever to position 3. All the fingers should be free of the platen.

6. If the tension bar needs adjustment loosen the 3/32 Allen screw on the clamp and rotate the paper tension bar to obtain the correct measurement outlined in steps 4 and 5.

7. If the requirements in steps 4 and 5 cannot be met, perform the cam adjustment described on page 16-14.

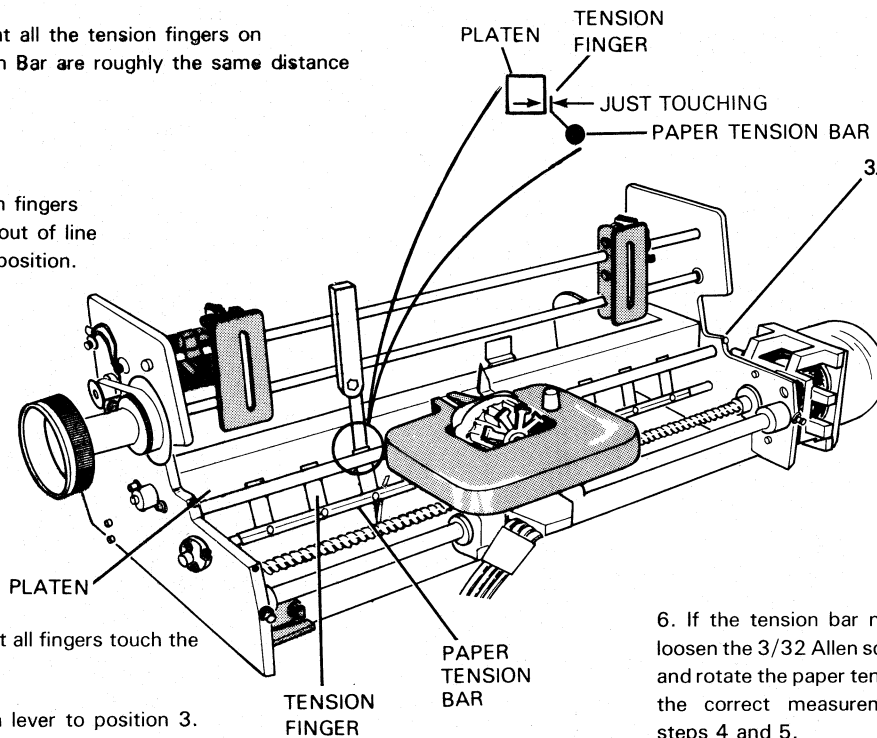

DG-06181

Figure 16.11 Paper Tension Bar Adjustment

Mechanism Final Test

A properly adjusted mechanism should print correctly at 235 c.p.s. in self-test mode without causing any faults. The test procedure is as follows.

1 Set up the scope to perform the motor speed adjustment

2 Start the self-test and slowly increase the motor speed until the period between motor pulses is 1.4 ms (print rate approximately 235 c.p.s.).

3 If a motion fault occurs, the mechanism is not properly set up. If a period of 1.4 ms cannot be obtained, set the motor speed pot to minimum carriage velocity. Bridge R42 with a 50 K Ω resistor and repeat steps 1 through 3.

Appendix A

ASCII - 128 CHARACTER CODES

NAME OR MNEMONIC	ACTION TAKEN BY PRINTER	ASCII CODE (OCTAL)	DECIMAL EQUIVALENT	KEYS " PRESSED TO GENERATE CODE
NUL	None	000	000	CTRL O
SOH	None	001	001	CTRL A
STX	None	002	002	CTRL B
ETX	Reserved	003	003	CTRL C
EOT	Reserved	004	004	CTRL D
ENQ	None	005	005	CTRL E
ACK	Reserved	006	006	CTRL F
BEL	Sounds audible tone	007	007	CTRL G
BS	Back Space (online only)	010	008	CTRL H-BS-SHIFT BS-CTRL BS
HT	Horizontal Tab	011	009	CTRL I-TAB-SHIFT TAB-CTRL TAB
NL	Newline (Line Feed)	012	010	CTRL J-LF-SHIFT LF-CTRL LF
VT	Vertical Tab *	013	011	CTRL K
FF	Form Feed *	014	012	CTRL L
CR	Carriage Return	015	013	CTRL M-CR-SHIFT CR-CTRL CR-(NP)
SO	Selects Alternate Character Set	016	014	CTRL N
S1	Selects Standard Character Set	017	015	CTRL O
DLE	None	020	016	CTRL P
DC1	None	021	017	CTRL Q
DC2	None	022	018	CTRL R
DC3	None	023	019	CTRL S
DC4	None	024	020	CTRL T
NAK	None	025	021	CTRL U
SYN	None	026	022	CTRL V
ETB	None	027	023	CTRL W
CAN	None	030	024	CTRL X
EM	None	031	025	CTRL Y
SUB	None	032	026	CTRL Z
ESC	Begins Command Seq.	033	027	CTRL [-ESC-SHIFT ESC-CTRL ESC
FS	None	034	028	CTRL
GS	None	035	029	CTRL _
RS	None	036	030	CTRL ,
US	None	037	031	CTRL -
SP	Space	040	032	SPACE BAR

Table A.1

NAME OR MNEMONIC	ACTION TAKEN BY PRINTER	ASCII CODE (OCTAL)	DECIMAL EQUIVALENT	KEY(S) PRESSED TO GENERATE
Exclamation	Prints !	041	033	SHIFT ! OR CTRL SHIFT !
Quotation Mark	Prints "	042	034	SHIFT " OR CTRL SHIFT "
Number Sign	Prints #	043	035	SHIFT # OR CTRL SHIFT #
Dollar Sign	Prints \$	044	036	SHIFT \$ OR CTRL SHIFT \$
Percent Sign	Prints %	045	037	SHIFT % OR CTRL SHIFT %
Ampersand	Prints &	046	038	SHIFT & OR CTRL SHIFT &
Apostrophe	Prints '	047	039	SHIFT ' OR CTRL SHIFT /
Open Parenthesis	Prints (050	040	SHIFT (OR CTRL SHIFT (
Close Parenthesis	Prints)	051	041	SHIFT) OR CTRL SHIFT)
Asterisk	Prints *	052	042	SHIFT * OR CTRL SHIFT *
Plus Sign	Prints +	053	043	SHIFT + OR CTRL SHIFT +
Comma	Prints ,	054	044	, OR CTRL ,
Hyphen (Minus Sign)	Prints -	055	045	- OR CTRL -
Period (Decimal Point)	Prints .	056	046	. OR CTRL . (NP)
Slash	Prints /	057	047	/ OR CTRL /
Zero	Prints 0	060	048	0 OR CTRL 0 (NP)
One	Prints 1	061	049	1 OR CTRL 1 (NP)
Two	Prints 2	062	050	2 OR CTRL 2 (NP)
Three	Prints 3	063	051	3 OR CTRL 3 (NP)
Four	Prints 4	064	052	4 OR CTRL 4 (NP)
Five	Prints 5	065	053	5 OR CTRL 5 (NP)
Six	Prints 6	066	054	6 OR CTRL 6 (NP)
Seven	Prints 7	067	055	7 OR CTRL 7 (NP)
Eight	Prints 8	070	056	8 OR CTRL 8 (NP)
Nine	Prints 9	071	057	9 OR CTRL 9 (NP)
Colon	Prints :	072	058	SHIFT : OR CTRL SHIFT :
Semicolon	Prints ;	073	059	; OR CTRL ;
Less Than	Prints <	074	060	SHIFT < OR CTRL SHIFT <
Equal Sign	Prints =	075	061	= OR CTRL =
Greater Than	Prints >	076	062	SHIFT > OR CTRL SHIFT >
Question Mark	Prints ?	077	063	SHIFT ? OR CTRL SHIFT ?
Commercial At	Prints @	100	064	SHIFT @ OR CTRL SHIFT @
A	Prints A	101	065	SHIFT A
B	Prints B	102	066	SHIFT B
C	Prints C	103	067	SHIFT C
D	Prints D	104	068	SHIFT D
E	Prints E	105	069	SHIFT E
F	Prints F	106	070	SHIFT F
G	Prints G	107	071	SHIFT G
H	Prints H	110	072	SHIFT H
I	Prints I	111	073	SHIFT I
J	Prints J	112	074	SHIFT J
K	Prints K	113	075	SHIFT K
L	Prints L	114	076	SHIFT L
M	Prints M	115	077	SHIFT M
N	Prints N	116	078	SHIFT N
O	Prints O	117	079	SHIFT O
P	Prints P	120	080	

ASCII - 128 CHARACTER CODES

NAME OR MNEMONIC	ACTION TAKEN BY PRINTER	ASCII CODE (OCTAL)	DECIMAL EQUIVALENT	KEY(S) PRESSED TO GENERATE
Q	Prints Q	121	081	SHIFT Q
R	Prints R	122	082	SHIFT R
S	Prints S	123	083	SHIFT S
T	Prints T	124	084	SHIFT T
U	Prints U	125	085	SHIFT U
V	Prints V	126	086	SHIFT V
W	Prints W	127	087	SHIFT W
X	Prints X	130	088	SHIFT X
Y	Prints Y	131	089	SHIFT Y
Z	Prints Z	132	090	SHIFT Z
Opening Bracket	Prints [133	091	[
Back Slash	Prints \	134	092	\
Close Bracket	Prints]	135	093]
Circumflex	Prints ^	136	094	SHIFT ^
Underline	Prints _	137	095	SHIFT _
Accent Grave	Prints `	140	096	`
a	Prints a	141	097	A
b	Prints b	142	098	B
c	Prints c	143	199	C
d	Prints d	144	100	D
e	Prints e	145	101	E
f	Prints f	146	102	F
g	Prints g	147	103	G
h	Prints h	150	104	H
i	Prints i	151	105	I
j	Prints j	152	106	J
k	Prints k	153	107	K
l	Prints l	154	108	L
m	Prints m	155	109	M
n	Prints n	156	110	N
o	Prints o	157	111	O
p	Prints p	160	112	P
q	Prints q	161	113	Q
r	Prints r	162	114	R
s	Prints s	163	115	S
t	Prints t	164	116	T
u	Prints u	165	117	U
v	Prints v	166	118	V
w	Prints w	167	119	W
x	Prints x	170	120	X
y	Prints y	171	121	Y
z	Prints z	172	122	Z
Open Baroque Parenthesis	Prints {	173	123	{
Vertical Mark Parenthesis	Prints	174	124	SHIFT
Close Baroque Parenthesis	Prints }	175	125	SHIFT }
TILDE	Prints ~	176	126	SHIFT ~
DELETE	None	177	127	DEL-SHIFT DEL-CTRL DEL-CTRL SHIFT DEL



Appendix B

SUMMARY OF CONTROL CODES AND ESCAPE SEQUENCES

NAME	MNEMONIC	CONTROL CODE (OCTAL)	EFFECT
Bell	BEL	007	Codes received Sounds audible tone.
Back Space	BS	010	Print head moves back one character position.(Only when online)
Horizontal Tab	HT	011	Print head moves to next horizontal tab stop. If no tab is set, the command is ignored.
Newline (Line Feed)	NL	012	Terminates the present line, advances the paper one line, and either: a) determines the fastest way to print the next line (if it is complete), or b) performs a carriage return and prints any characters from left to right.
Vertical Tab	VT	013	Paper advances to next tab stop. If no tab is set, a carriage return is executed. No paper movement occurs.
Form Feed	FF	014	Paper advances to the top of the next form. If the automatic form feed option is not installed, a carriage return is executed. No paper movement occurs.
Carriage Return	CR	015	Carriage returns to the left-hand margin.
Shift Out	SO	016	Selects alternate character set. (Model 1192 Option)
Shift In	SI	017	Selects standard character set.
Escape	ESC	033	Denotes the beginning of a command sequence.
Device 1 Control	DC1	021	Codes transmitted Indicates that the character buffer has room for more data.
Device 3 Control	DC3	023	Indicates that the character buffer is nearly full.

Table B.1 DASHER LP2 and TP2 Printer Control Codes

Escape Sequence	Octal Codes	Function
ESC 1	033 061	Sets a horizontal tab at the current printhead position.
ESC 2	033 062	Clears a horizontal tab from the current printhead position.
ESC E #.. CTRL-0	033 105 #.. 000	Sets horizontal tabs at the column positions specified by the octal number(s) #. All previous tabs are cleared.
ESC E CTRL-0	033 105 000	Clears all horizontal tabs.
ESC 5	033 065	Sets a vertical tab at the current line position.
ESC 6	033 066	Clears a vertical tab from the current position.
ESC F #.. CTRL-0	033 106 #.. 000	Sets vertical tabs at the line positions specified by the octal number(s) #. All previous tabs are cleared.
ESC F CTRL-0	033 106 000	Clears all vertical tabs.
ESC <	033 074	Selects elongated printing for subsequent characters.

Table B.2 Escape Sequences

SUMMARY OF CONTROL CODES AND ESCAPE SEQUENCES

Escape Sequence	Octal Codes	Function
ESC =	033 075	Clears a elongated printing for subsequent characters.
ESC >	033 076	Selects the compressed printing mode.
ESC ?	033 077	Selects the normal print mode.
ESC a	033 141	Starts underscoring subsequent characters.
ESC b	033 142	Stops underscoring subsequent characters.
ESC c	033 143	Performs a master reset.
ESC d	033 144	Selects plot mode.
ESC e	033 145	Deselects plot mode.
ESC Y ...	033 131	Beginning of character set load sequence (see DGC No. 014-000094).
ESC N Starting Character Set Address	033 116 ----	Selects down line loaded character set (see DGC No. 014-000094).
ESC O	033 117	Deselects a down line loaded character set.

Escape Sequences



Appendix C

JUMPERING

The main control board (all models) and options board (TP2 printers only) contain hardware jumpers which configure various hardware and software options. Insert these jumpers as indicated in Figure C.1.

Main Control Board

How main control board is jumpered depends on the revision board installed. Consult the illustration below:

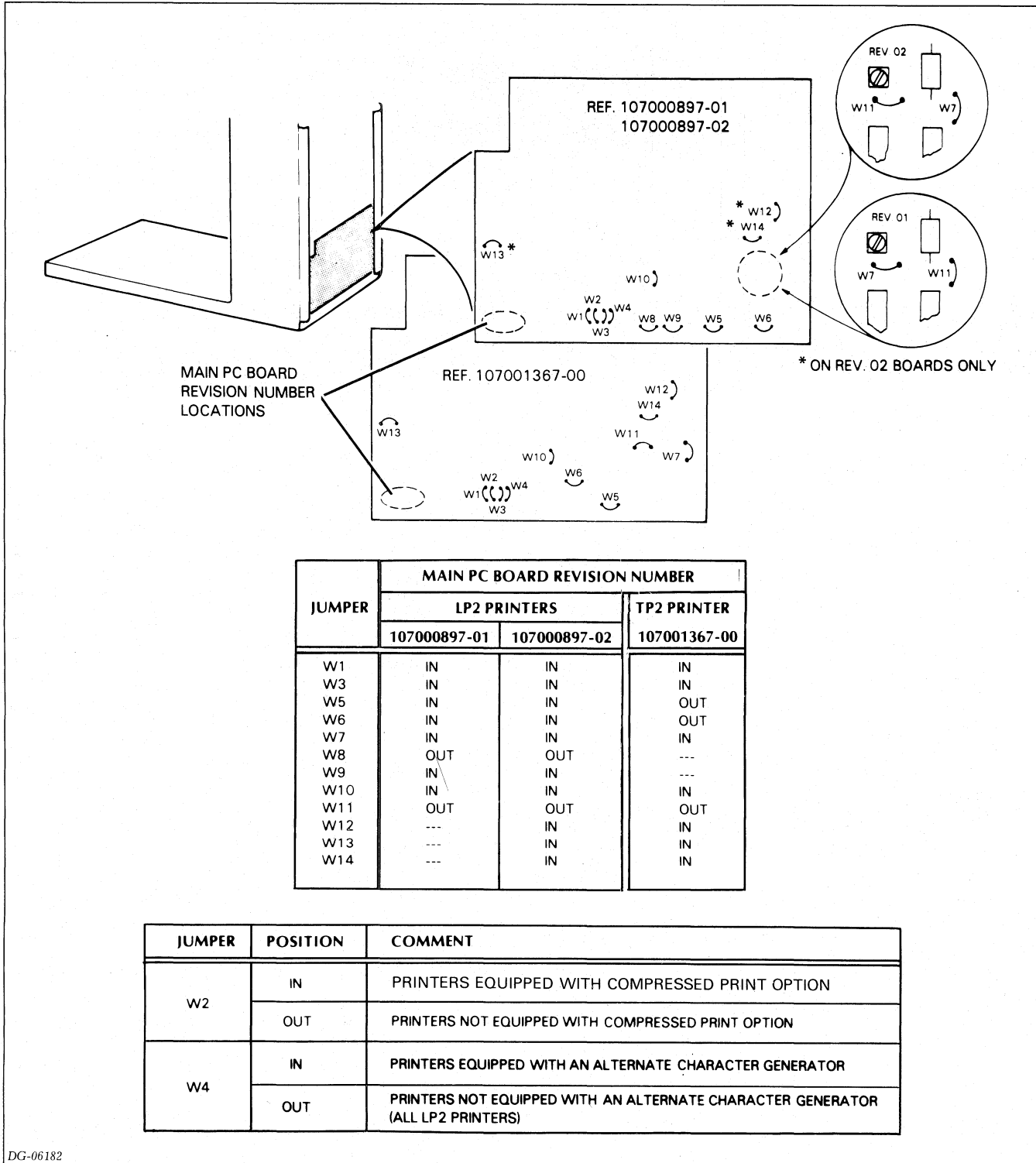

DG-06182

Figure C.1 Main Control Board Jumpers

Options Board

The options board (TP2 printer) is jumpered as indicated in Figure C.2.

JUMPERING

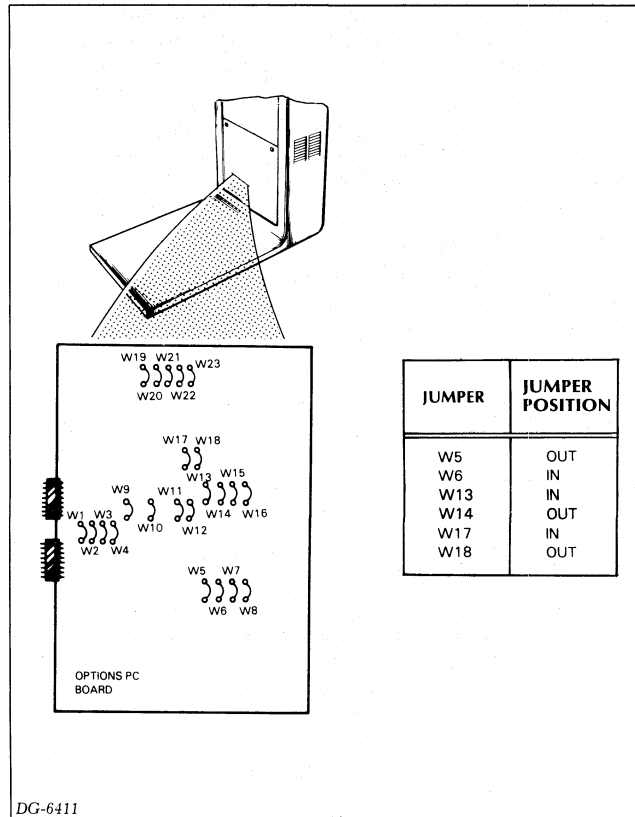

DG-6411

Figure C.2 Options Board Jumpers (TP2 Printer)

Serial Interface Configuration Jumpers

Jumpers W19-W23 select the parity, number of data bits, and the number of stop bits that the serial interface transmits and expects to receive. The selections made by these jumpers should agree with the configuration of the related controller (some controllers are configured by jumpers while others are configured through software).

NOTE: Select the appropriate transmission rate by using the Baud Rate switch located on the secondary control panel.

Selects	Jumper	Position			
PARITY	W19	IN	} EVEN	IN } ODD	OUT } MARK PARITY
	W23	OUT			
STOP BITS	W20	IN = 1		OUT = 2	
DATA BITS	W21	OUT	} 7 DATA BITS	OUT	} 8 DATA BITS
	W22	IN		OUT	

Table C.1 Serial Interface Configuration Jumpers

Local Copy Select Jumpers

Jumpers W15 and W16 enable local copy mode in TP2 keyboard send-receive printers. When this mode is enabled, a character generated by the keyboard is printed at the same time it is transmitted by the serial interface. When disabled, a character generated by the keyboard is transmitted without first being printed. Unless special software is being used, a printer should be configured to disable local copy since most software "echos" characters received from terminals. This feature should also be disabled on receive-only DASHER TP2 printers.

Jumper	Local Copy Enable	Local Copy Disable
W15	IN	OUT
W16	OUT	IN

Table C.2 Local Copy Select Jumpers

Software Busy Jumpers

Jumpers W11 and W12 enable the software busy feature. When this feature is enabled, the printer automatically transmits special control codes which direct the host to stop and start transmission of the data stream to the printer. The software busy or XON/XOFF protocol requires that the printer transmit a DC3(023_g) when the print buffer is nearly full and a DC1(021_g) when the buffer becomes half empty. The first control code tells the computer or communications system to stop transmitting data to the printer while the second code indicates that transmission should be resumed. If the feature is disabled, neither code is transmitted.

If the software busy feature is enabled, a full duplex connection must exist between the printer and the computer. Also, this feature must be used in conjunction with a software handler routine able to interpret the special control codes transmitted by the printer. If the feature is not used, insert the jumpers to disable its operation.

Jumper	Software Busy Enable	Software Busy Disable
W11	OUT	IN
W12	IN	OUT

Table C.3 Software Busy Select Jumpers

Local Hardware Busy Enable Jumpers

In local connections to a computer (i.e., not through a modem), jumpers W7 and W10 enable the busy signal, *Request To Send* (on the EIA connector), to be used as a busy line. When enabled, the printer drives *Request To Send* to the low state to signal the computer to stop transmitting data. When disabled, RTS always remains at a high level. Note that these jumpers take on a different meaning when the printer is connected through a modem

(see Modem Configuration Jumpers, below). Also, these jumpers have no effect on the busy signal supplied to the current loop connector (see Appendix D).

Jumper	Hardware Busy Enable (RTS)	Hardware Busy Disable
W7 W10	IN OUT	OUT IN

Table C.4 Hardware Busy Enable Jumpers

Modem Configuration Jumpers

Jumpers W8 and W9 enable the modem Auto-Answer/Auto-Disconnect feature which allows TP2 printers to be connected to modems capable of automatically answering incoming calls.

When enabled, the modem alerts the printer to a call by driving the control line, *Data Set Ready*, to the high state. The printer, if ready, responds by driving *Data Terminal Ready* to a high state. At this point, data received on the Receive Data line is printed. The printer places the modem on-hook by allowing *Data Terminal Ready* to go low. If no data is received within the first 30 seconds after answering a call, or data transmission to the printer is suspended for more than 30 seconds, the printer disconnects from the circuit by placing the modem on-hook.

When the feature is disabled, the *Data Set Ready* and *Data Terminal Ready* control signals remain high.

The feature should be disabled when not being used or when the printer is used in conjunction with a manual answer modem.

Jumper	Auto-Answer Auto-Disconnect Disable	Auto-Answer Auto-Disconnect Enable
W8 W9	IN OUT	OUT IN

Table C.5 Modem Auto-Answer Jumpers

Jumpers W7 and W10 select between full and half duplex modem connections. If full duplex mode is selected, the printer can transmit and receive data at the same time. If half duplex mode is selected, the printer places the control signal, *Request To Send*, high whenever it wishes to transmit data. However, the printer must then wait for the modem to place the *Clear To Send* control signal high before it can transmit. A full duplex connection should always be selected unless the printer is connected to a half duplex modem.

Jumper	Full Duplex Connection	Half Duplex Connection
W7 W10	OUT IN	IN OUT

Table C.6 Modem Duplex Mode Jumpers

Jumpers W1 - W4 select either an EIA RS-232-C or a 20mA current loop type connection for the *Receive Data* and *Transmit Data* signals supplied on the 25-pin modem connector.

Jumper	EIA	20mA Current Loop
W1	IN	OUT
W2	OUT	IN
W3	OUT	IN
W4	IN	OUT

Table C.7 Modem Connector Jumpers

Appendix D

EXTERNAL CABLES

DASHER TP2 Printer I/O Cables

A DASHER TP2 I/O cable connects the printer's serial interface to an asynchronous serial controller or a modem. A cable is attached to a TP2 printer via one of three connectors. The two 6-pin Molex connectors provide either EIA RS-232-C or 20mA current loop connections. These connectors should be used when connecting the printer to an asynchronous controller (the EIA connector can be used to attach the printer to a BELL 103 compatible manual answer modem). The 25-pin Cannon connector provides a full complement of the EIA RS-232-C standard modem control signals. This connector should be used when connecting the printer to a BELL 212 compatible auto-answer modem. The location for all three connectors are shown in Figures D.1 and D.2.

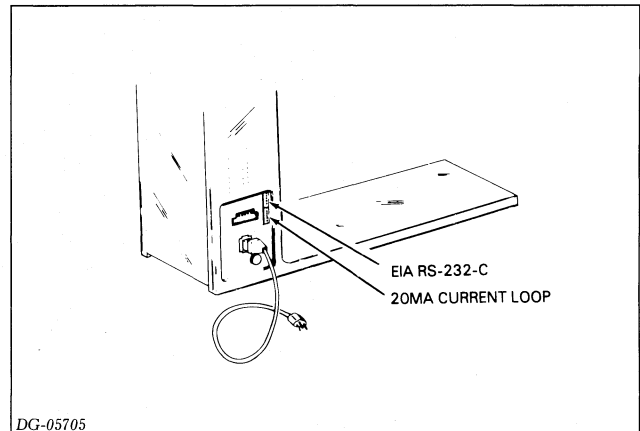

Figure D.1 DASHER TP2 Printer (EIA/Current Loop Connections)

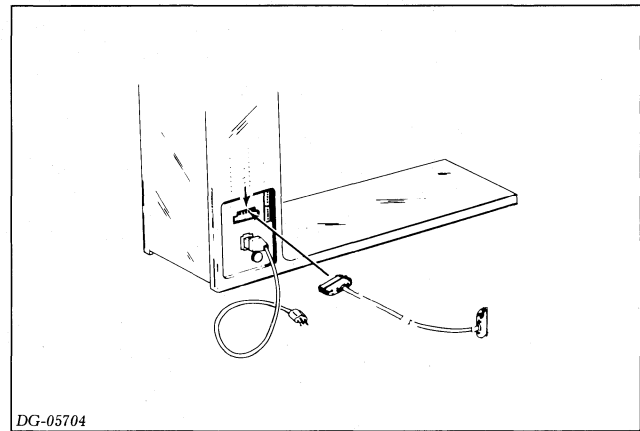

Figure D.2 DASHER TP2 Printer (Modem Connector)

Cable Connects		Remarks	Cable Number	Wire List
TP2 Connector	DGC Computer/Controller			
EIA	NOVA 800,830, 840, 1200	---	005007889	008002002
EIA	MicroNOVA	---	005007888	008002003
EIA	NOVA 2,3,4,820,1210, 1220;ECLIPSE S100, S200, S230, C300, C330, S130, C150, AP130	---	005010603	008002507
EIA	M600, S250, C350; ULM-5	---	005010707	008002542
EIA	ALM-8, CS/40, CS/60	TP2 is a secondary device on the CS/40 and CS/60.	005008181	008002033
Current Loop/EIA	ALM-16	Baud rates up to 4800 baud can be run if DC1 and DC3 are used.	005007636	008000971
EIA	Modem 6054 option	Used with manual answer modems.	005007637	008000973
Modem	Modem	Used with Auto- answer, Auto Disconnect Modems	005014692	008002188
EIA	CS/20	For RO printers only.	005008833	008002552
Current Loop	CS/40, CS/60	Allows use of current loop Busy signal. Cable length depends on 005 cable number.	005009692	008002125
			005009806 through 005009810	
Current Loop	ULM-5		005010707	008002542

Table D.1 Dasher TP2 Printer External Cables

The various cables available to connect a TP2 printer to the different DGC serial asynchronous controllers or to a modem are illustrated in Figure D.3. The table indicates which cable should be used for each configuration.

NOTE: A cable attached to the EIA or modem connector should be no longer than 50 feet (15.2 meters). A cable attached to the current loop connector should be no longer than 1500 feet (457 meters).

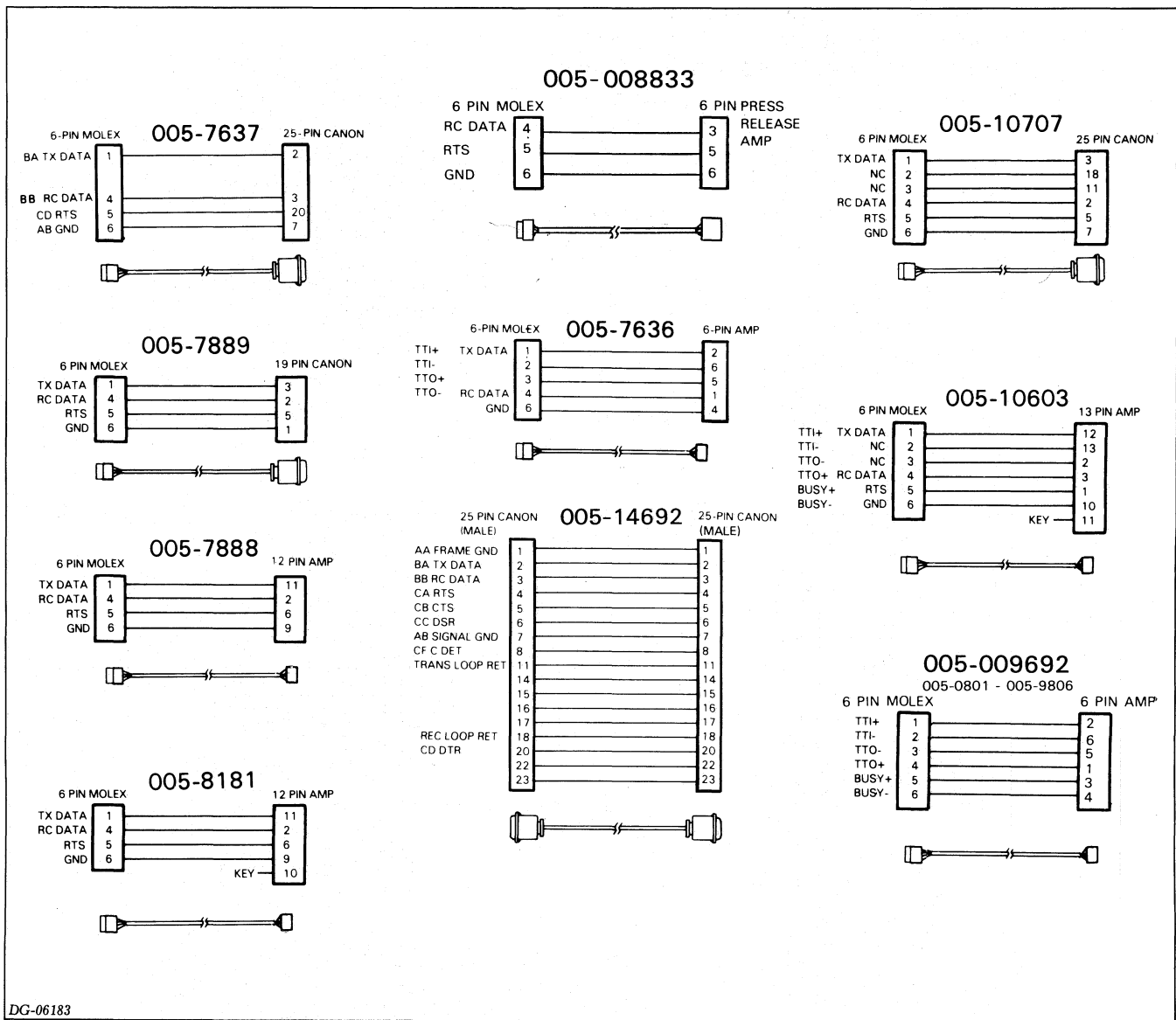

DG-06183

Figure .3 Serial Interface Cables

DASHER LP2 Printer I/O Cables

A DASHER LP2 I/O cable connects the printer's parallel interface to a line printer controller mounted in a DGC computer chassis. The cable attaches to the LP2 printer via the 36-pin Amplenol connector located on the bottom rear side of the pedestal. The connector's location is shown in Figure D.4.

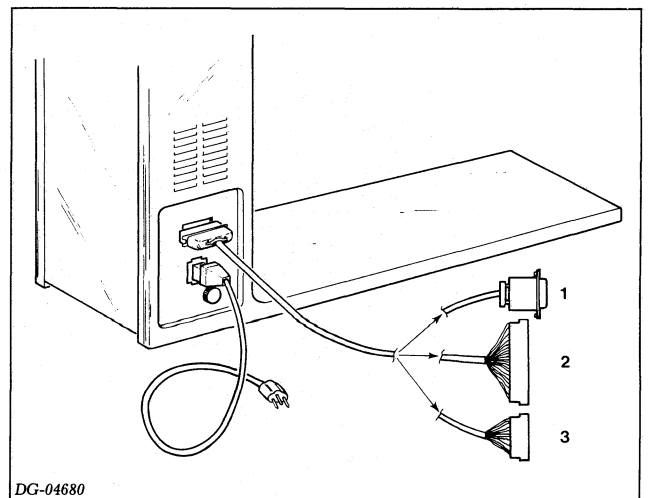

DG-04680

Figure .4 DASHER LP2 Printer (Parallel Interface)

DGC Computer	DGC Controller	Cable #	Wire List #
NOVA 800,830,840, 1200	Programmed I/O 005003564	005001246	008000310
	Data Channel 005008096	005012100	008003203
NOVA 2,3,4,820,1210, 1220, ECLIPSE S100, S200,S230,C300, C330,S130,C150, AP/130, M/600	Programmed I/O 005003564	005001356	00800304
	Data Channel 005008096	005012099	008003202
microNOVA CS/20,40,60	005008448	005008452	008000995
	---	005009060	008002086

The various cables available to connect an LP2 printer to the different DGC computers and controllers are illustrated below. Table D.4 indicates which cable should be used for each configuration.

NOTE: No cable should be longer than 25 feet (7.4 meters) in length.

Table D.2 DASHER LP2 Printer External Cables

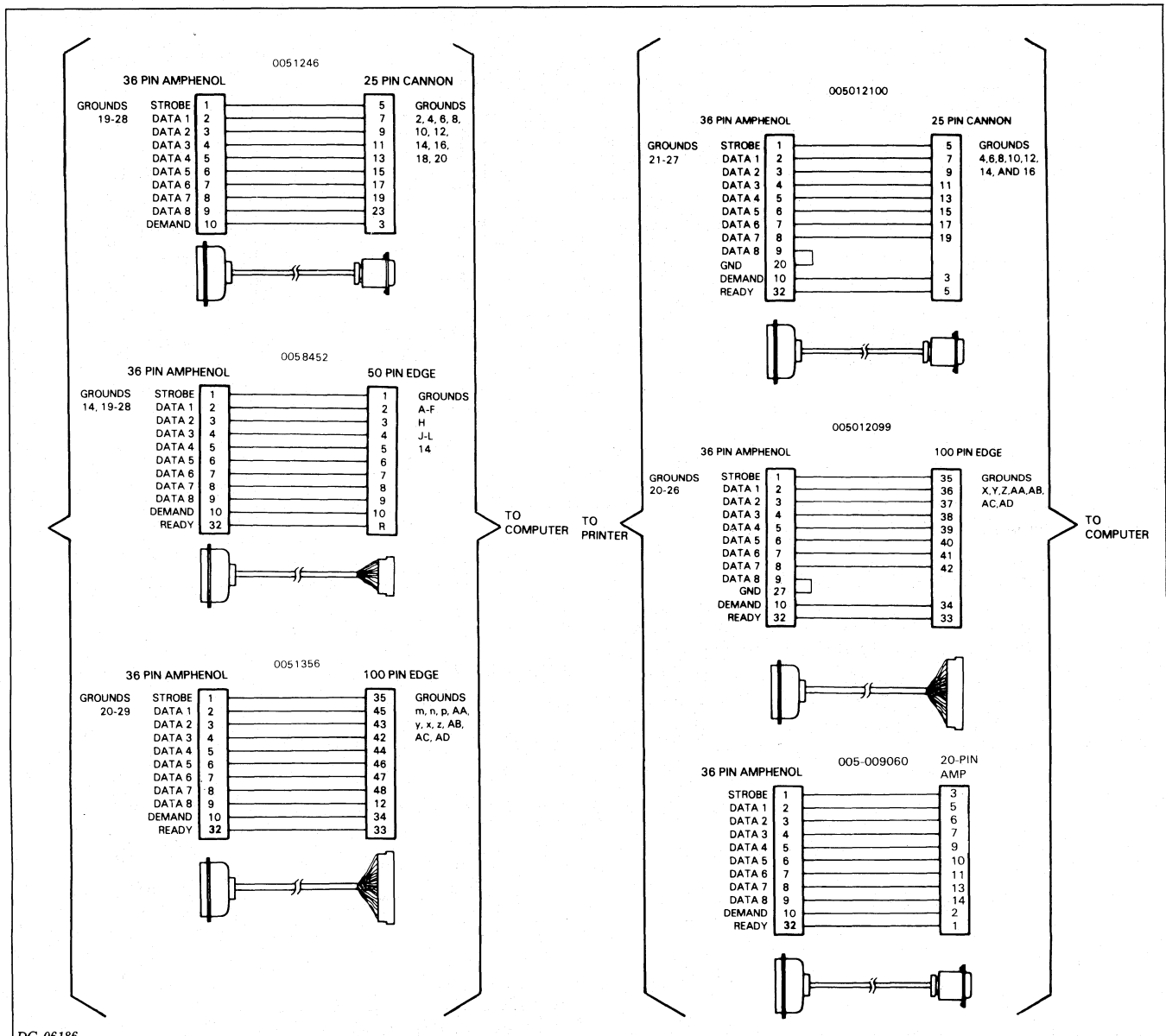

DG-06186

Figure D.5 Parallel Interface Cables

EXTERNAL CABLES

Power Cable

Two power cables are available for use with an LP2 or a TP2 printer. The first cable is used when running a printer off a 120 volt line; the second cable is used when running the printer off a 220-240 volt line. The power cable connector's location is illustrated below, along with the part numbers of the two cables.

Power Cable	DGC Part #
120 Volts, 13A	109000238
220/240 Volts, 15A	109000240

Power Cable Part Numbers

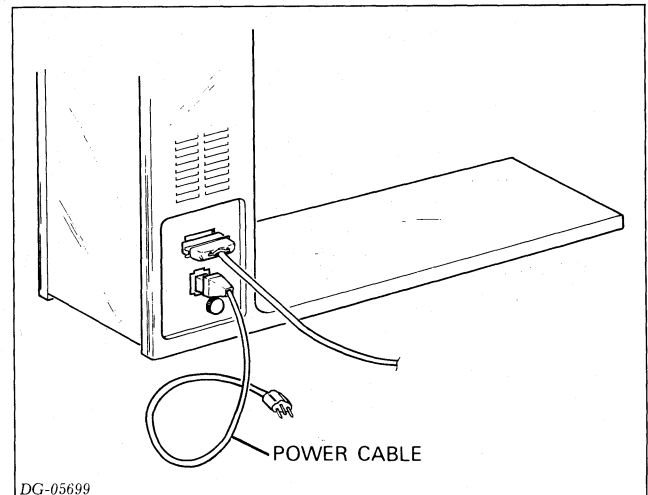
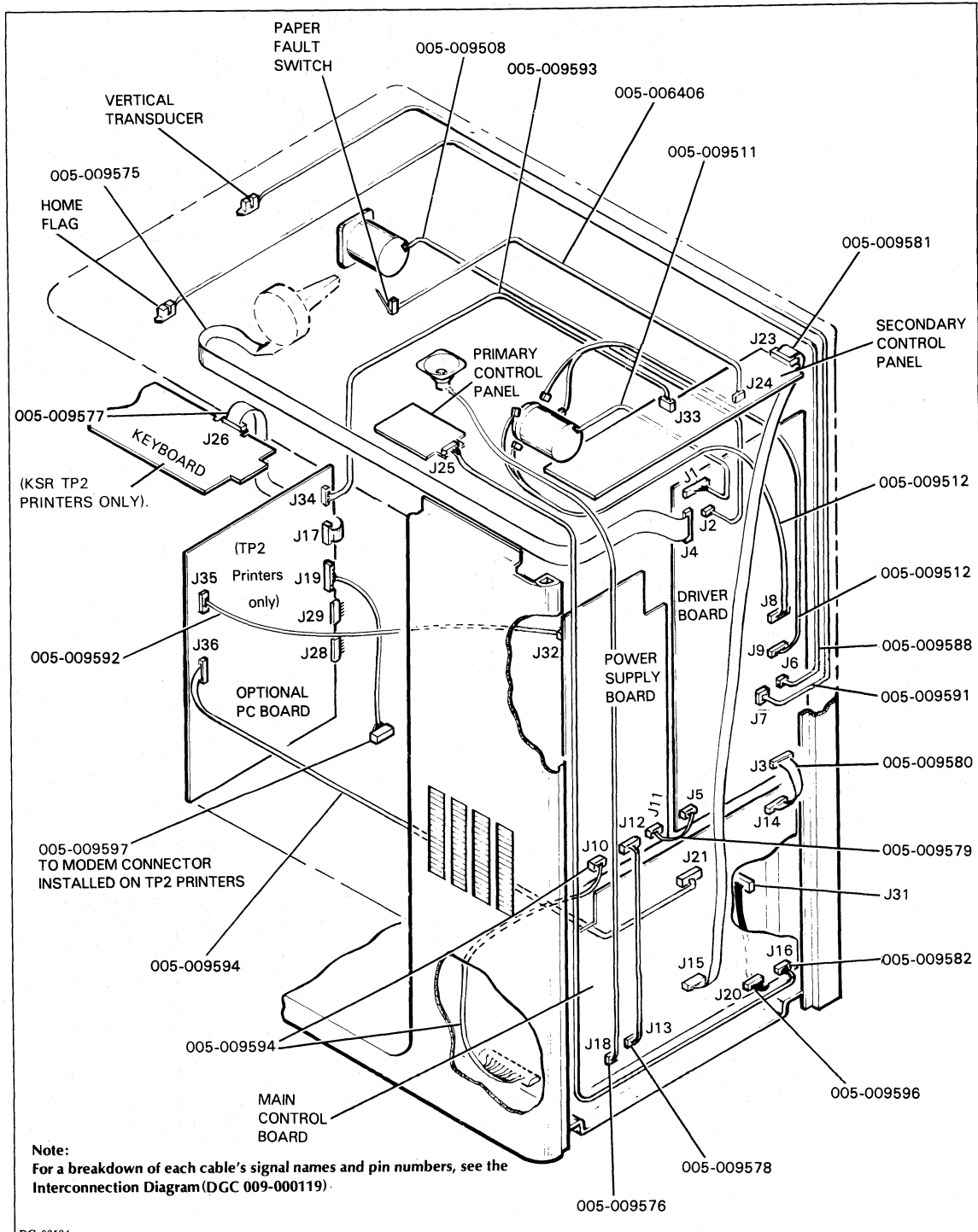

Figure D.6 Power Line Circuit Breaker



Appendix E

INTERNAL CABLING AND INTERCONNECTION DIAGRAM



DC-06184

Figure .1 Internal Cabling

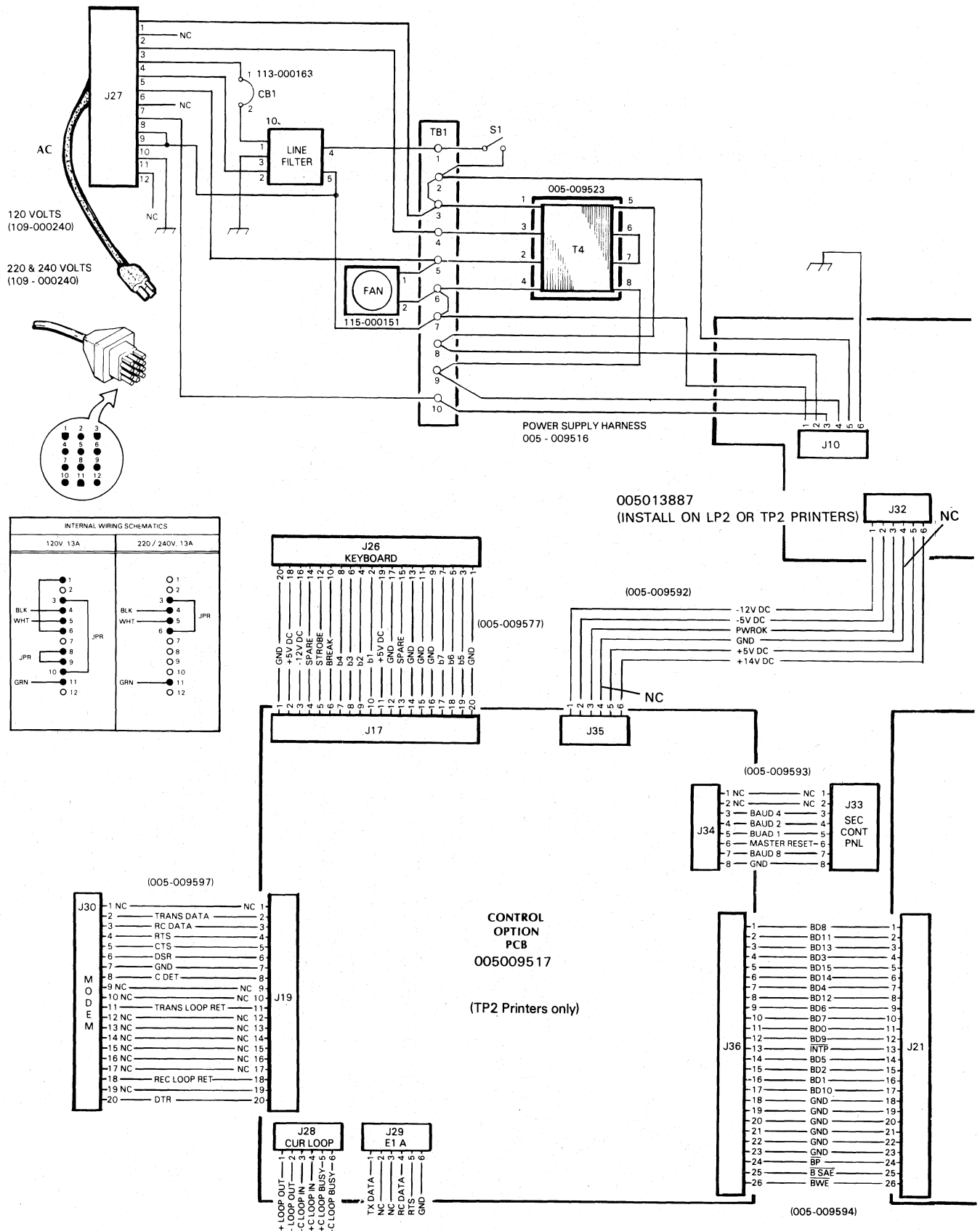

DG-06187

Figure E.2 Interconnection Diagram

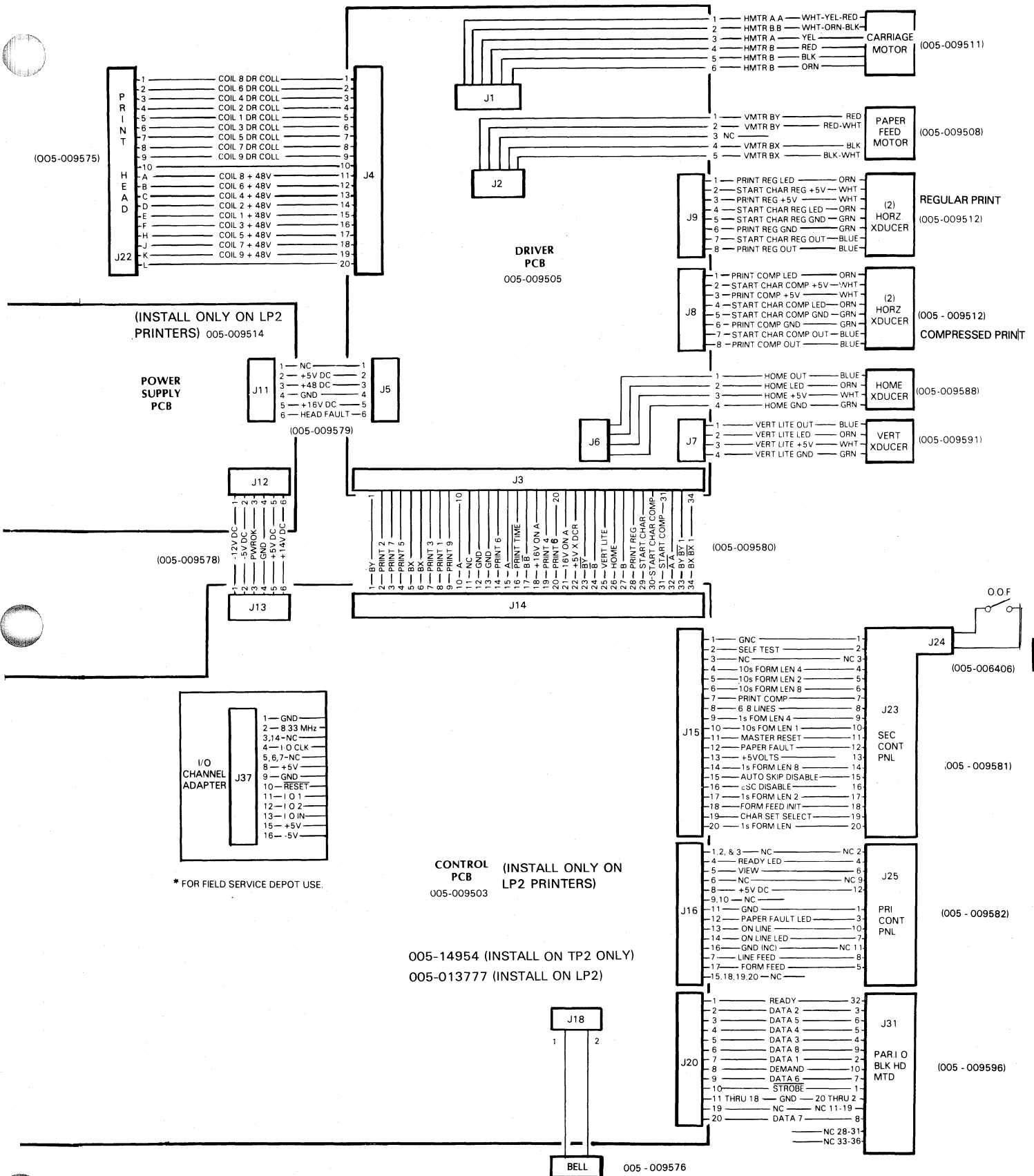

INTERNAL CABLING AND INTERCONNECTION DIAGRAM

Appendix F

FIELD REPLACEMENT UNIT PART NUMBERS

Unit	DGC Part No.
Printed Circuit Boards:	
Main Control Board	
LP2 Printers	005013777
TP2 Printers	005014954
Character Generator:	
US	100001099
French	100001364
UK	100001365
Swedish	100001366
German	100001367
Driver Board	005009505
Power Supply Board	
LP2 printers only	005009514
LP2 or TP2 printers	005013887
Primary Control Panel	005006407
Switch (OFF/ON LINE, VIEW)	110000132
Switch (LINE/FORM FEED)	110000255
Secondary Control Panel:	
For Model 6074 (includes Norm/Comp switch)	005011991
For Model 6076, 6078 (same as above out includes Baud switch for TP2 printers)	005009519
Replacement Switches for all Secondary Control Panels:	
Toggle Switch (NORM/COMP, LPI, PERF SKIP, STD ALI CHAR SET)	110000035
Thumbwheel Switch	110000329
Pushbutton Switch (TOF INIT, MST RST, FORMS OVERRIDE)	110000330
Momentary/Toggle Switch (SELF TEST)	110000363
Rotary Switch (BAUD RATE) (TP2 only)	110000351
Options Board (TP2 printers)	005009517
Keyboard with Numeric Pad (TP2 PRINTERS)	118000676

Unit	DGC Part No.
Carriage Assembly	
Bearing, Leadscrew (2 each)	123000842
Bearing, Linear (2 each)	123001321
Clamp, Print Disc(s)	002006164
Coupling Clamp (2 per assembly)	002007927
Disc, Compressed Print	002006149
Disc, Normal Print	002006148
Leadscrew and Anti-backlash Nut (matched set)	118000675
Motor, Carriage	005009511
Plastic Coupling Adapter	002006166
Printhead	118000573
Retainer Rings (linear bearings, 4 each)	123001264
Ribbon Gearbox	005009509
Ribbon Gearbox Steel Cable	118000696
Shim (leadscrew)	123000843
Transducers, Optical (2 per assembly, 4 with compressed print)	005009591
Paper Feed Assembly:	
Clamp, Paper Feed Motor Shaft	002004134
Disc, Paper Feed (same as Normal Print Disc in Carriage Assembly)	002006148
Drive Belt	123000946
Drive Pulley	002006551
Motor, Paper Feed	005009508
Switch, Out Of Forms	110000261
Tractors, Paper Feed (matched pair)	118000699
Transducer, Optical	005009591
Other:	
Fan	115000151
Transformer (T4)	005009523

DG OFFICES

SALES AND SERVICE OFFICES

Alabama: Birmingham
Arizona: Phoenix, Tucson
Arkansas: Little Rock
California: El Segundo, Fresno, Los Angeles, Oakland, Palo Alto, Pasadena, Sacramento, San Diego, San Francisco, Santa Ana, Santa Barbara, Van Nuys
Colorado: Denver, Englewood
Connecticut: North Branford, Norwalk
Florida: Ft. Lauderdale, Orlando, Tampa
Georgia: Norcross
Idaho: Boise
Iowa: Cedar Rapids Bettendorf
Illinois: Arlington Heights, Champaign, Chicago, Peoria, Rockford, Schaumburg
Indiana: Indianapolis
Kentucky: Louisville
Louisiana: Baton Rouge, Metairie
Maine: Portland
Maryland: Baltimore
Massachusetts: Cambridge, Springfield, Wellesley, Worcester
Michigan: Grand Rapids, Southfield
Minnesota: Richfield
Missouri: Creve Coeur, Kansas City, St. Louis
Mississippi: Jackson
Montana: Billings
Nebraska: Omaha
Nevada: Las Vegas, Reno
New Hampshire: Bedford, Nashua
New Jersey: Cherry Hill, Somerset, Wayne
New Mexico: Albuquerque
New York: Albany, Buffalo, Lake Success, Latham, Melville, Newfield, New York, Rochester, Syracuse, White Plains
North Carolina: Charlotte, Greensboro, Greenville, Raleigh
Ohio: Brooklyn Heights, Cincinnati, Columbus, Dayton
Oklahoma: Oklahoma City, Tulsa
Oregon: Lake Oswego, Portland
Pennsylvania: Blue Bell, Carnegie, Lancaster, Philadelphia, Pittsburgh
Rhode Island: Providence, Rumford
South Carolina: Columbia
Tennessee: Knoxville, Memphis, Nashville
Texas: Austin, Dallas, El Paso, Ft. Worth, Houston, San Antonio
Utah: Salt Lake City
Virginia: McLean, Norfolk, Richmond, Salem
Washington: Bellevue, Kirkland, Richland, Spokane
West Virginia: Charleston
Wisconsin: Brookfield, Madison, West Allis

INTERNATIONAL SUBSIDIARIES

Australia: Adelaide, Melbourne, New Castle, Sydney, Tasmania, Queensland, Victoria
Brazil: Sao Paulo
Canada: Calgary, Edmonton, Montreal, Ottawa, Quebec, Toronto, Vancouver, Winnipeg
France: Lille, Lyon, Nantes, Paris
Italy: Florence, Milan, Padua, Rome, Turin
Japan: Tokyo
The Netherlands: Amsterdam, Rijswijk
New Zealand: Auckland, Wellington
Sweden: Gothenburg, Malmoe, Stockholm
Switzerland: Lausanne, Zurich
United Kingdom: Birmingham, Bristol, Cheshire, Glasgow, Hounslow, London, Manchester
West Germany: Dusseldorf, Filderstadt, Frankfurt, Hamburg, Hannover, Munich, Nuremberg, Munich, Ratingen, Rodelheim, Stuttgart

DG-04976

REPRESENTATIVES & DISTRIBUTORS

Argentina: Buenos Aires
Bolivia: Novadata
Chile: Santiago
Columbia: Bogato
Costa Rica: San Jose
Ecuador: Quito
Egypt: Cairo
Finland: Helsinki
Guatemala: Guatemala City
Hong Kong: Hong Kong
India: Bombay
Indonesia: Jakarta
Israel: Givatayim
Korea: Seoul
Kuwait: Kuwait
Lebanon: Beirut
Malaysia: Kuala Lumpur
Mexico: Mexico City, Nuevo Leon
Morocco: Casablanca
Nicaragua: Managua
Nigeria: Ibadan, Lagos
Norway: Oslo
Paraguay: Asuncion
Peru: Lima
Philippine Islands: Manila
Portugal: Lisbon
Puerto Rico: Hato Rey
Saudi Arabia: Jaddah, Riyadh
Singapore: Singapore
South Africa: Capetown, Durban, Johannesburg, Pretoria
Spain: Barcelona, Bilbao, Madrid, San Sebastian, Valencia
Taiwan: Taipei
Thailand: Bangkok
Turkey: Ankara
Uruguay: Montevideo
Venezuela: Maracaibo

ADMINISTRATION, MANUFACTURING RESEARCH AND DEVELOPMENT

Massachusetts: Cambridge, Framingham, Southboro, Westboro
Maine: Westbrook
New Hampshire: Portsmouth
California: Anaheim, Sunnyvale
North Carolina: Research Triangle Park, Johnston County
Texas: Austin

Hong Kong: Kowloon, Tai Po
Thailand: Bangkok

MEMORANDUM

TO: THE PRESIDENT

FROM: [Illegible]

[Illegible text block]

[Illegible text block]

DATE: [Illegible]

[Illegible text block]

[Illegible text block]

[Illegible text block]

[Illegible text block]

[Illegible text block]

[Illegible text block]

Engineering Publications Comment Form

Please help us improve our future publications by answering the questions below. Use the space provided for your comments.

Title: _____

Document No. _____

Yes	No		
<input type="checkbox"/>	<input type="checkbox"/>	Is this manual easy to read?	<input type="radio"/> You (can, cannot) find things easily. <input type="radio"/> Other: <input type="radio"/> Language (is, is not) appropriate. <input type="radio"/> Technical terms (are, are not) defined as needed.
		In what ways do you find this manual useful?	<input type="radio"/> Learning to use the equipment <input type="radio"/> To instruct a class. <input type="radio"/> As a reference <input type="radio"/> Other: <input type="radio"/> As an introduction to the product
<input type="checkbox"/>	<input type="checkbox"/>	Do the illustrations help you?	<input type="radio"/> Visuals (are, are not) well designed. <input type="radio"/> Labels and captions (are, are not) clear. <input type="radio"/> Other:
<input type="checkbox"/>	<input type="checkbox"/>	Does the manual tell you all you need to know? What additional information would you like?	
<input type="checkbox"/>	<input type="checkbox"/>	Is the information accurate? (If not please specify with page number and paragraph.)	

Name: _____ Title: _____

Company: _____ Division: _____

Address: _____ City: _____

State: _____ Zip: _____ Telephone: _____ Date: _____

FOLD

FOLD

STAPLE

STAPLE

FOLD

FOLD



BUSINESS REPLY MAIL
FIRST CLASS PERMIT NO. 26 SOUTHBORO, MA. 01772

Postage will be paid by addressee:

 **Data General**

ATTN: ENGINEERING PUBLICATIONS

Southboro, Massachusetts 01772

NO POSTAGE
NECESSARY
IF MAILED
IN THE
UNITED STATES

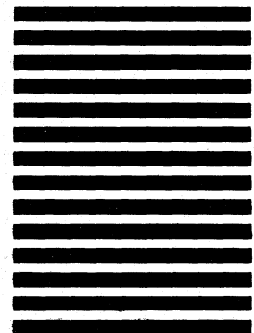

DataGeneral

Users Group

Installation Membership Form

Name _____ Position _____ Date _____

Company, Organization or School _____

Address _____ City _____ State _____ Zip _____

Telephone: Area Code _____ No. _____ Ext. _____

1. Account Category

OEM
 End User
 System House
 Government

5. Mode of Operation

Batch (Central)
 Batch (Via RJE)
 On-Line Interactive

2. Hardware

	Qty. Installed	Qty. On Order
M/600	_____	_____
C/350, C/330, C/300	_____	_____
S/250, S/230, S/200	_____	_____
S/130	_____	_____
AP/130	_____	_____
CS Series	_____	_____
N3/D	_____	_____
Other NOVA	_____	_____
microNOVA	_____	_____
Other _____	_____	_____
(Specify) _____	_____	_____

6. Communications

RSTCP CAM
 HASP 4025
 RJE80 Other
 SAM

Specify _____

3. Software

AOS RDOS
 DOS RTOS
 SOS Other

Specify _____

7. Application Description

○ _____

4. Languages

Algol Assembler
 DG/L Interactive
 Cobol Fortran
 ECLIPSE Cobol RPG II
 Business BASIC PL/1
 BASIC Other

Specify _____

8. Purchase

From whom was your machine(s) purchased?

Data General Corp.
 Other
 Specify _____

DG-05810

9. Users Group

Are you interested in joining a special interest or regional Data General Users Group?

○ _____

FOLD

FOLD

STAPLE

STAPLE

FOLD

FOLD



BUSINESS REPLY MAIL
FIRST CLASS PERMIT NO. 26 SOUTHBORO, MA. 01772

Postage will be paid by addressee:

 **Data General**

ATTN: Users Group Coordinator

Southboro, Massachusetts 01772

NO POSTAGE
NECESSARY
IF MAILED
IN THE
UNITED STATES

