

**DASHER™  
LP2 AND TP2  
PRINTERS**

**ILLUSTRATED  
PARTS BREAKDOWN**

016-000647-01

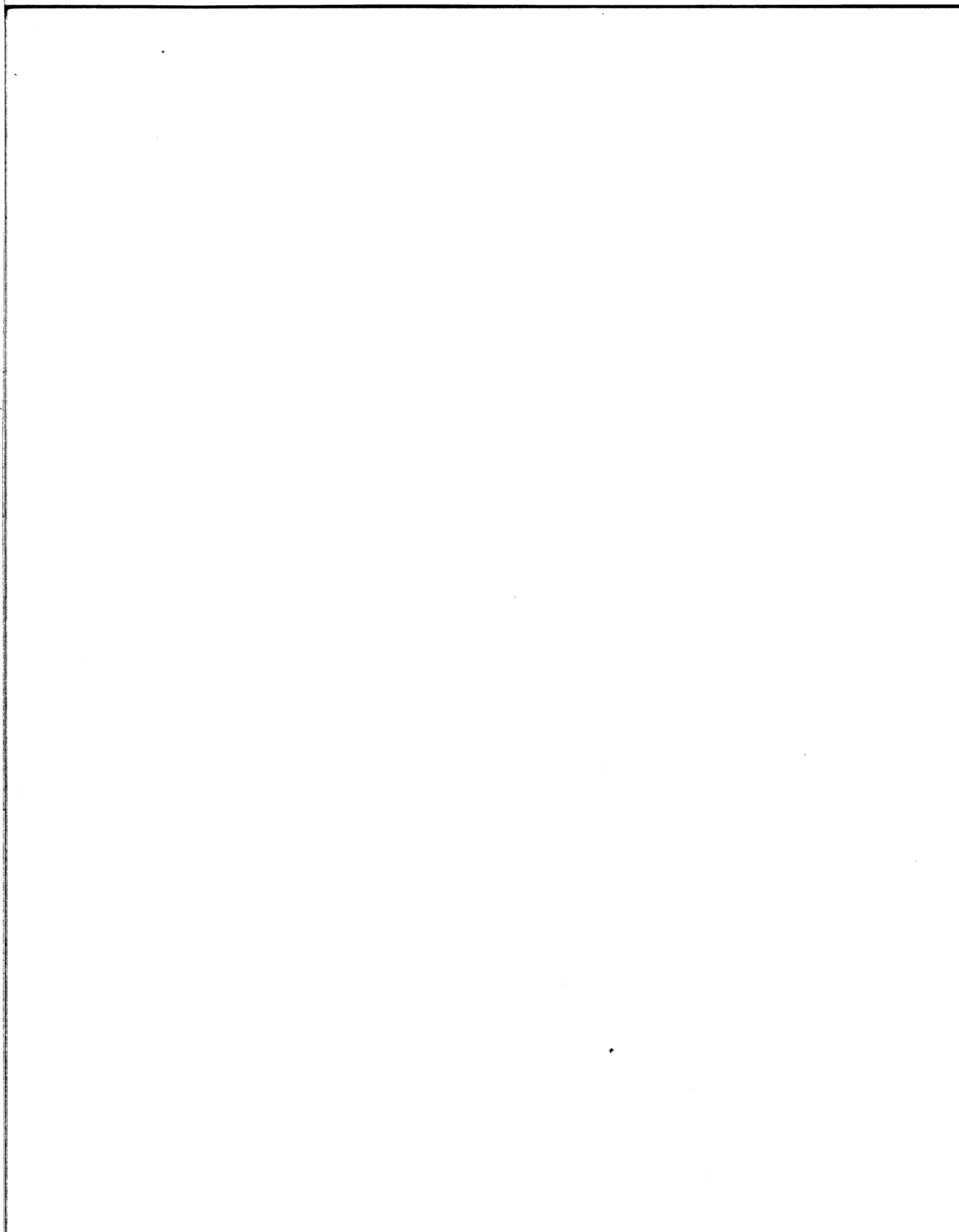

**DASHER™  
LP2 AND TP2  
PRINTERS**

**ILLUSTRATED  
PARTS BREAKDOWN**

016-000647-01

## NOTICE

Data General Corporation (DGC) has prepared this manual for use by DGC personnel and customers as a parts-ordering guide and to show proper sequence of assembly and dis-assembly. The drawings and parts lists contained herein are the property of DGC and shall neither be reproduced in whole or in part without DGC prior written approval nor be implied to grant any license to make, use, or sell equipment manufactured in accordance herewith.

DGC reserves the right to make changes without notice in the specifications and materials contained herein and shall not be responsible for any damages (including consequential) caused by reliance on the materials presented, including but not limited to typographical or arithmetic errors, company policy and pricing information.

**NOVA**, **INFOS**, and **ECLIPSE** are registered trademarks of Data General Corporation, Westboro, Massachusetts. **DASHER** and **microNOVA** are trademarks of Data General Corporation, Westboro, Massachusetts.

# **DASHER™ LP2 AND TP2 PRINTERS**

## **Illustrated Parts Breakdown**

### **PREFACE**

*The Illustrated Parts Breakdown is a pictorial representation of the DASHER LP2 AND TP2 terminal printer subsystems, it shows what parts are required and how they fit within the subsystem. Each part listed is identified with a unique DGC ordering number.*

*The first drawing (page I-1) illustrates the major assemblies of the subsystem, and subsequent drawings illustrate and list each part of the major assemblies. The printed circuit board subassemblies are listed, their component parts are given on 016 drawings which are listed but not included. (001) schematics and (103) PCB artwork drawings are referenced but not included.*

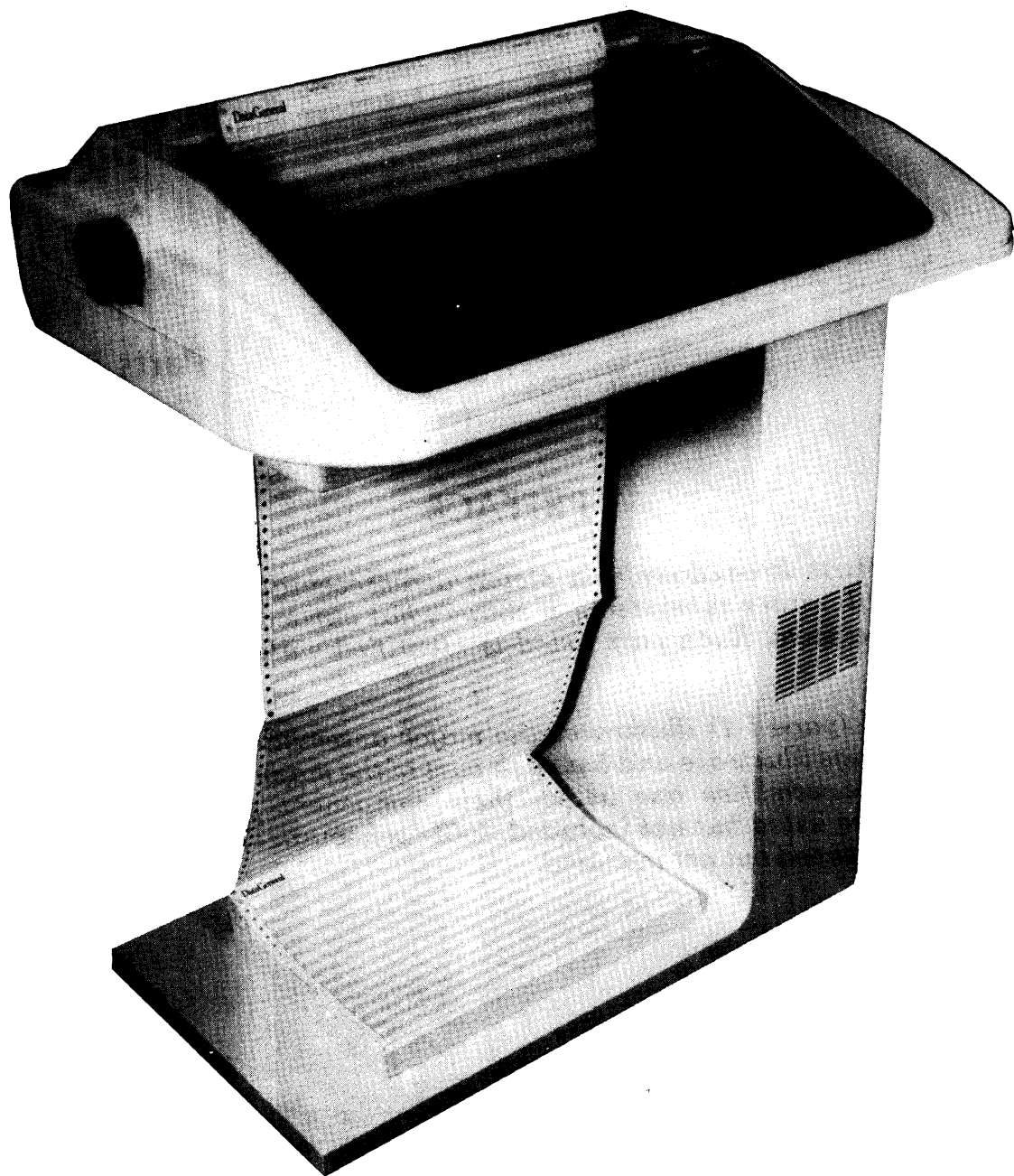

# CONTENTS

## **CHAPTER I      SUBSYSTEM & PACKAGING**

- 2      SUBSYSTEM KEY SHEET**
- 4      SHIPPING PACKAGE**

## **CHAPTER II      EXTERNAL CABLES**

- 2      CABLE, EXTERNAL LINE PRINTER**
- 2      I/O CABLE LP2 TO DCH CTL 800/1200**
- 4      CABLE, EXTERNAL LINE PRINTER**
- 4      I/O CABLE LP2 TO DCH CTL 820/1220**
- 6      CABLE EXTERNAL LINE PRINTER-microNOVA™**
- 8      CABLE, POWER CORD**
- 10     FORMS RECEIVER BASKET**

## **CHAPTER III     MAIN ASSEMBLY**

- 2      MAIN ASSEMBLY**
- 4      GROUND WIRE KIT**
- 4      CONTROL LOGIC TO BELL CABLE**
- 6      POWER SUPPLY TO CONTROL LOGIC CABLE**
- 6      POWER SUPPLY TO DRIVER CABLE**
- 8      DRIVER TO CONTROL LOGIC CABLE**
- 8      CONTROL LOGIC TO SECONDARY CONTROL CABLE**
- 10     CONTROL LOGIC TO CONTROL PANEL CABLE**
- 10     CONTROL TO PAR I/O CABLE**
- 12     PEDESTAL**
- 14     POWER SUPPLY HARNESS**
- 16     TRANSFORMER**
- 16     TRANSFORMER JUMPER WIRE KIT**

CONTENTS CONTINUED

18	MECHANISM
26	PLATEN SERIAL PRINTER
26	CABLE, OUT OF FORM SWITCH
28	PAPER FEED MOTOR
28	CARRIAGE MOTOR
30	RIBBON DRIVE
30	RIBBON CARTRIDGE
32	CARRIAGE DRIVE
32	CARRIAGE DRIVE COND. PRINT
34	TRANSDUCER ASSEMBLY, COMPRESSED ASSEMBLY
36	HOME TRANSDUCER CABLE
36	PAPER FEED TRANSDUCER
38	PRINT HEAD TO DRIVE CABLE
40	EQUIPMENT LABELS
42	CABLE ROUTING DIAGRAM
43	INTERCONNECTION DIAGRAM

## APPENDIX A      PREFIX CODE TABLE



**CHAPTER 1**  
**SUBSYSTEM & PACKAGING**

SUBSYSTEM KEY SHEET

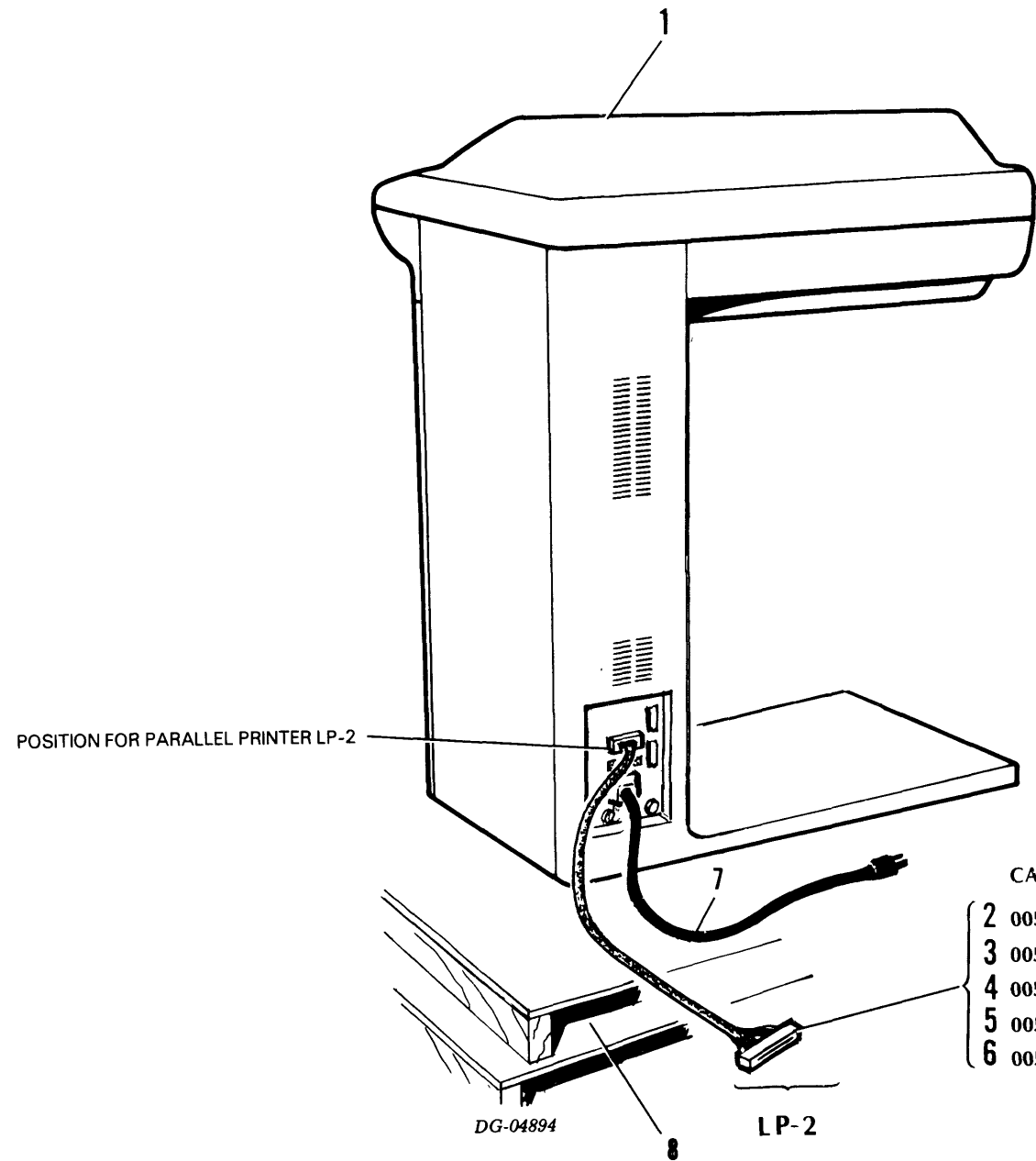

CABLE, EXT		
2	005001246	11-2
3	005012100	11-2
4	005001356	11-4
5	005012099	11-4
6	005008452	11-6

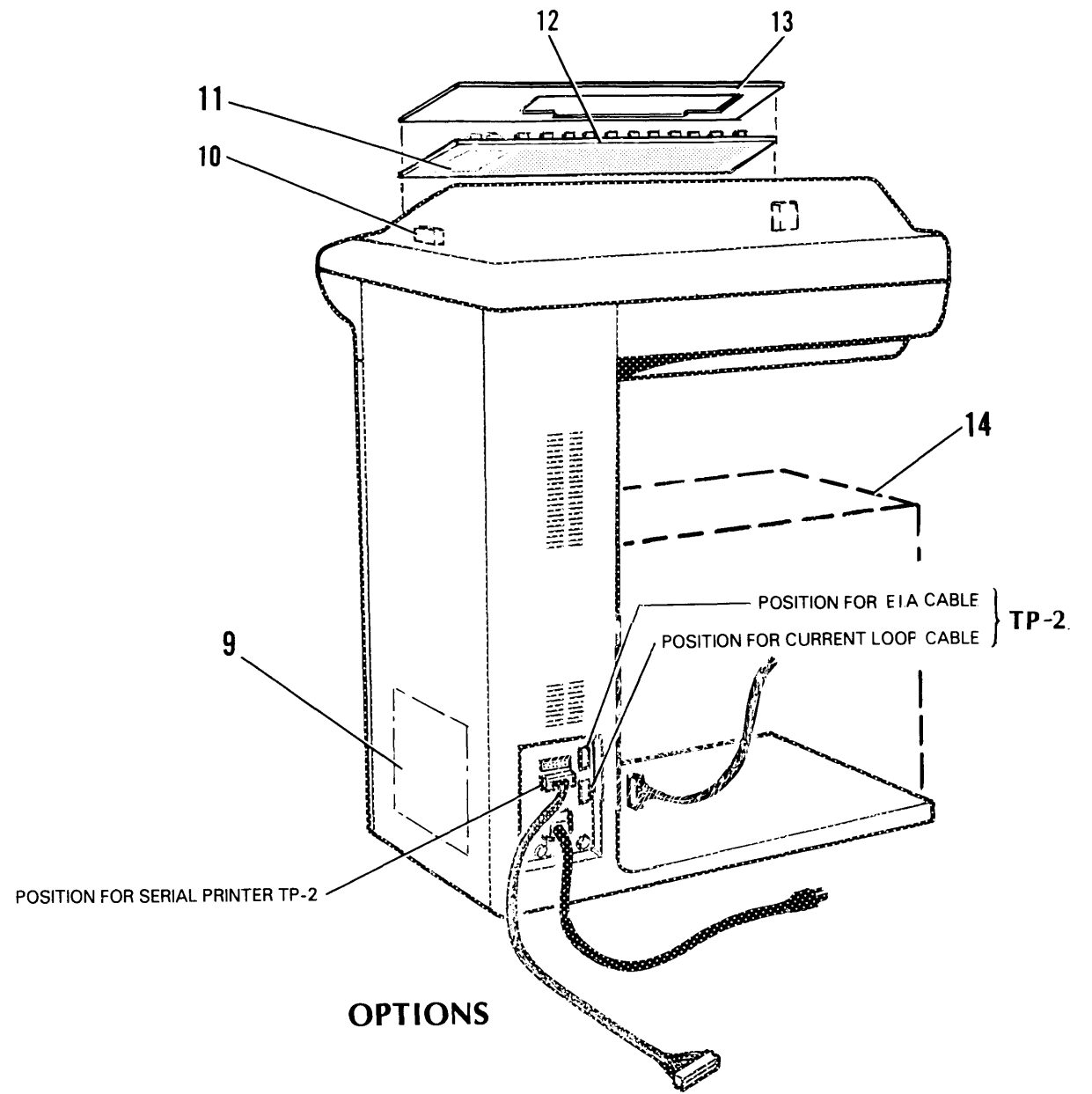

The drawings and parts lists contained herein are the property of DGC and shall neither be reproduced in whole or in part without DGC prior written approval nor be implied to grant any license to make, use, or sell equipment manufactured in accordance herewith.

PAGE & ITEM NO.	DESCRIPTION	QTY	DGC PART NO.	REF PAGE NO.
I-2 1	<p><b>MODEL 6073 60HZ</b> 50HZ RECEIVE-ONLY PRINTER AUTOMATIC FORM FEED</p> <p><b>MODEL (S) 6073 60HZ</b> RECEIVE-ONLY PRINTER</p> <p><b>MODEL 6074 60HZ</b> 50HZ</p> <p><b>MODEL (S) 6074 60HZ</b> RECEIVE-ONLY PRINTER AUTOMATIC FORM FEED, COMPRESSED PRINT</p> <p><b>MODEL 6075 60HZ</b> 50HZ RECEIVE-ONLY PRINTER, AUTOMATIC FORM FEED, SERIAL INTERFACE</p> <p><b>MODEL (S) 6075 60HZ</b> RECEIVE-ONLY PRINTER, SERIAL INTERFACE</p> <p><b>MODEL 6076 60HZ</b> 50HZ</p> <p><b>MODEL (S) 6076 60HZ</b> RECEIVE-ONLY PRINTER, AUTOMATIC FORM FEED, SERIAL INTERACE COMPRESSED PRINT</p> <p><b>MODEL 6077 60HZ</b> 50HZ KEYBOARD SEND/RECEIVE TERMINAL, AUTOMATIC FORM FEED, SERIAL INTERFACE, KEYBOARD, NUMERIC PAD</p> <p><b>MODEL (S) 6077 60HZ</b> KEYBOARD SEND/RECEIVE TERMINAL, SERIAL INTERFACE</p> <p><b>MODEL 6078 60HZ</b> 50HZ</p> <p><b>MODEL (S) 6078 60HZ</b> KEYBOARD SEND/RECEIVE TERMINAL AUTOMATIC FORM FEED, SERIAL INTERFACE, NUMERIC PAD, COMPRESSED PRINT.</p>	1	<p>005009583 005010689</p> <p>005010009</p> <p>005010005 005010692 005010005</p> <p>005009585 005010690</p> <p>005010013</p> <p>005010012 005010693 005010012</p> <p>005009500 005010688</p> <p>005010011</p> <p>005010014 005010691 005010014</p>	I-2, III-2

The drawings and parts lists contained herein are the property of DGC and shall neither be reproduced in whole or in part without DGC prior written approval nor be implied to grant any license to make, use, or sell equipment manufactured in accordance herewith.

PAGE & ITEM NO.	DESCRIPTION	QTY	DGC PART NO.	REF PAGE NO.
2	CABLE, EXT LINE PRINTER	1	005001246	II-2
3	I/O CABLE LP2 TO DCH CTL	1	005012100	II-2
4	CABLE, EXT LINE PRINTER	1	005001356	II-4
5	I/O CABLE LP2 TO DCH CLT 820/1220	1	005012099	II-4
6	CABLE, PRINTER M/NOVA	1	005008452	II-6
7	CABLE, POWER CORD (120V 13A) OR CABLE, POWER CORD (240V 13A)	1	109000238	II-8
8	SHIPPING PACKAGE	1	044000011	I-4
9	<p><b>OPTIONS</b></p> <p><b>SERIAL INTERFACE PCB</b> IPL PCB SCHEMATIC ARTWORK</p>	REF REF REF	005009517 016000540 001001225 107000914 110000351	
10	BAUD RATE SWITCH		110000351	
11	NUMERIC KEYPAD (S 1147)	5	005010018	
12	STANDARD KEYBOARD	1	118000677	I-2 III-2
	NUMERIC KEYBOARD (NOT SHOWN)	1	118000676	
13	COVER PANEL STANDARD	1	002006170	I-2 III-2
	COVER PANEL NUMERIC (NOT SHOWN)	1	002006171	
14	FORMS RECEIVER BASKET	1	005007875	II-10

The drawings and parts lists contained herein are the property of DGC and shall neither be reproduced in whole or in part without DGC prior written approval nor be implied to grant any license to make, use, or sell equipment manufactured in accordance herewith.



PAGE & ITEM NO.	DESCRIPTION	QTY	DGC PART NO.	REF PAGE NO.
I-4	<b>SHPG MTL DASHER 6040-43</b>	1	<b>044000011</b>	I-2
1	SHPG HSC 41 1/4X35 1/4X30 3/4	1	129000239	
2	STRAPPING POLYPROPYLENE	1	129000123	
3	STRAPPING SEAL	2	129000124	
4	REINFORCED SEALING TAPE 3"	1	129000027	
5	31X19.5X24 POLYBAG 3MILS GUS	1	129000106	
6	TAPE 2" FILAMENT 3M Y-8922	1	129000130	
7	WSHR FLAT #10 .219X.500X.049 SCDP	4	106000263	
8	WSHR LOCK SPLIT SCDP #10	2	106000629	
9	SCR PHH PNH SCDP 10-32X1/4	2	106000902	
10	SHPG BRKT, BOTTOM SER PTR	2	002006002	
11	NUT HEX SCDP 3/8-16	8	106000623	
12	WSHR LOCK SPLIT SCDP 3/8	8	106000622	
13	DE STUD, 30CPS LN PTR	4	002006088	
14	SHPG SER RDR PALLET 37X32.5X8.5	1	129000235	
15	SCR HEX HEAD SCDP 3/8-16X1 1/4	4	106000680	
16	WSHR FLAT SCDP 3/8	8	106000621	
17	SHPG WARNING TAG	4	129000327	
18	SCR HEX HD SCDP 1/4 20X1	4	106000762	
19	WSHR LOCK SPLIT SCDP 1/4	8	106000763	
20	WSHR FLAT SCDP 100X9/32IDX1/16THK	4	106000764	
21	WSHR FLAT RUBBER 5/160DX1"IDX1/16THK	4	106000904	
22	SCR HEX HD SCDP 1/4-20X5/8	4	106000529	
23	WSHR EXT TOOTH SCDP 3/8	4	106000561	
24	HEX NUT SCDP 1/4-20	4	106000475	

The drawings and parts lists contained herein are the property of DGC and shall neither be reproduced in whole or in part without DGC prior written approval nor be implied to grant any license to make, use, or sell equipment manufactured in accordance herewith.



# **CHAPTER II**

# **EXTERNAL CABLES**

### CABLE, EXT LINE PRINTER

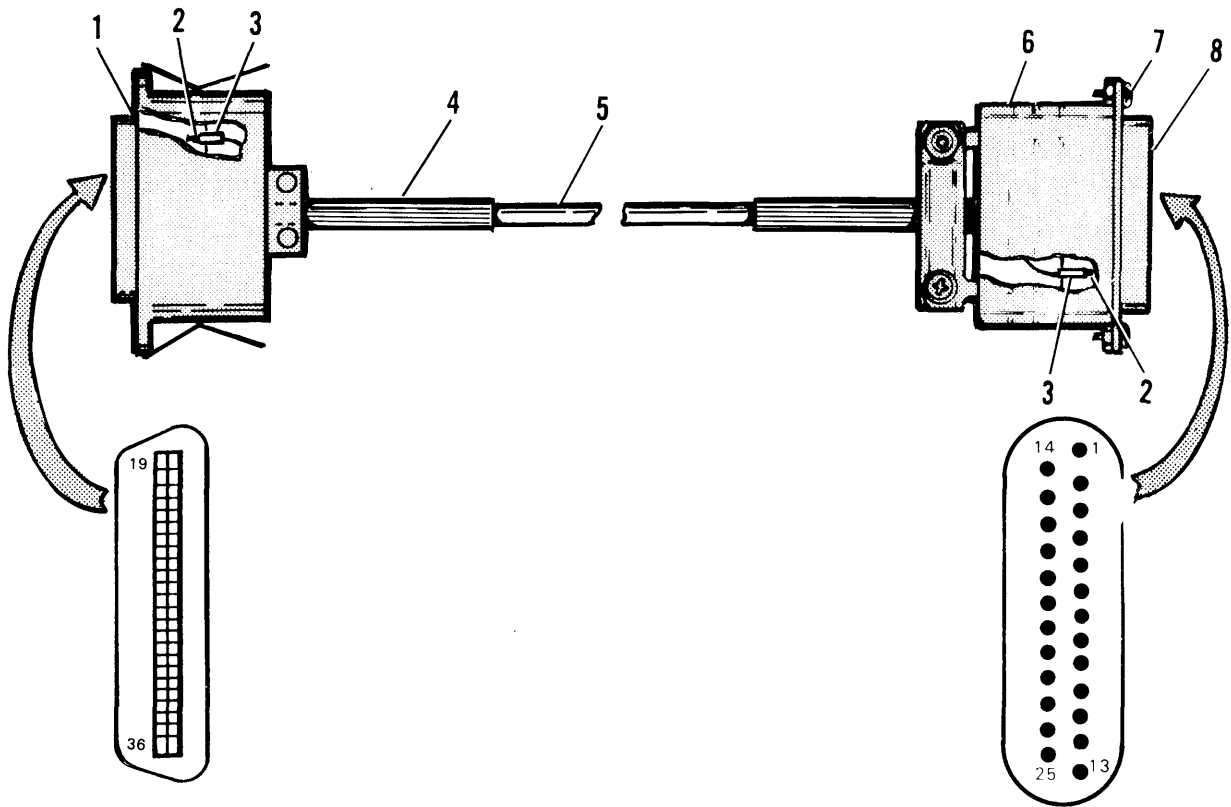

### CABLE I/O LP2 TO DCH CTL 800/1200

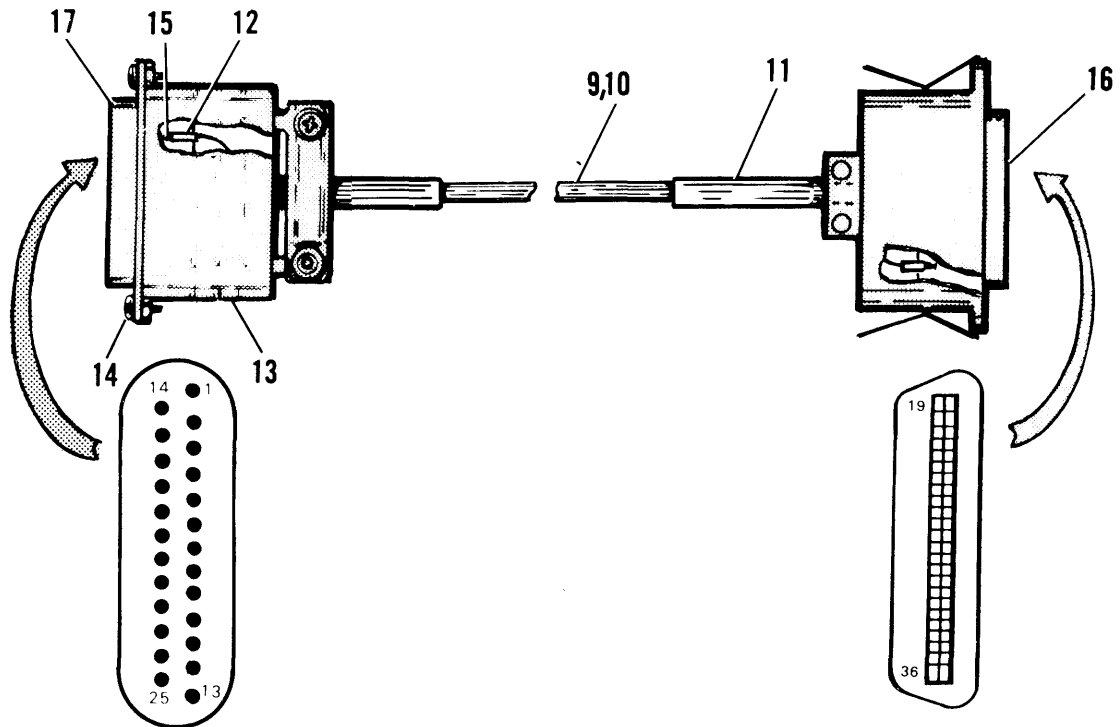

DG-04896

The drawings and parts lists contained herein are the property of DGC and shall neither be reproduced in whole or in part without DGC prior written approval nor be implied to grant any license to make, use, or sell equipment manufactured in accordance herewith.



PAGE & ITEM NO.	DESCRIPTION	QTY	DGC PART NO.	REF PAGE NO.
II-2 1 2 3 4 5 6 7 8	<b>CA EXT LINE PRINTER</b> CONN AMP 57-30360 CONN MALE/D110238-34 SLEEVING 3/32" HEAT SHRINK TUBING 1/2 DIA HEAT SHRINK BLK CABLE 24 AWG 14 TW PR CONN JUNCTION SHELL DB24659 CONN SCREW LOCK MALE 20419-21 CONN 25 CONT PLUG DBC25P W/O/PINS	1 1 21 11 10 25 1 1 1	<b>005001246</b> 111000152 111000146 109000098 109000061 109000062 111000020 111000024 111000333	I-2
II-2 9 10 11 12 13 14 15 16 17	<b>I/O CA LP2 TO DCH CTL 800/1200</b> WIRE TERMINATION WIRE 24 AWG 7/32 WHT CABLE 24 AWG 19-COND 7 X 32 TUBING 1/2 DIA HEAT SHRINK BLK SLEEVING 3/32" HEAT SHRINK CONN JUNCTION SHELL DB24659 CONN SCREW LOCK MALE 20419-21 CONN MALE/D 110238-34 CONN AMP 57-30360 CONN 25 CONT PLUG DBC25P W/O PINS	1 3.00" 1 1 1 1 2 17 1 1	<b>005012100</b> 029001401 109000049 109000045 109000061 109000098 111000020 111000024 111000146 111000152 111000333	I-2

The drawings and parts lists contained herein are the property of DGC and shall neither be reproduced in whole or in part without DGC prior written approval nor be implied to grant any license to make, use, or sell equipment manufactured in accordance herewith.

# CABLE, EXT LINE PRINTER

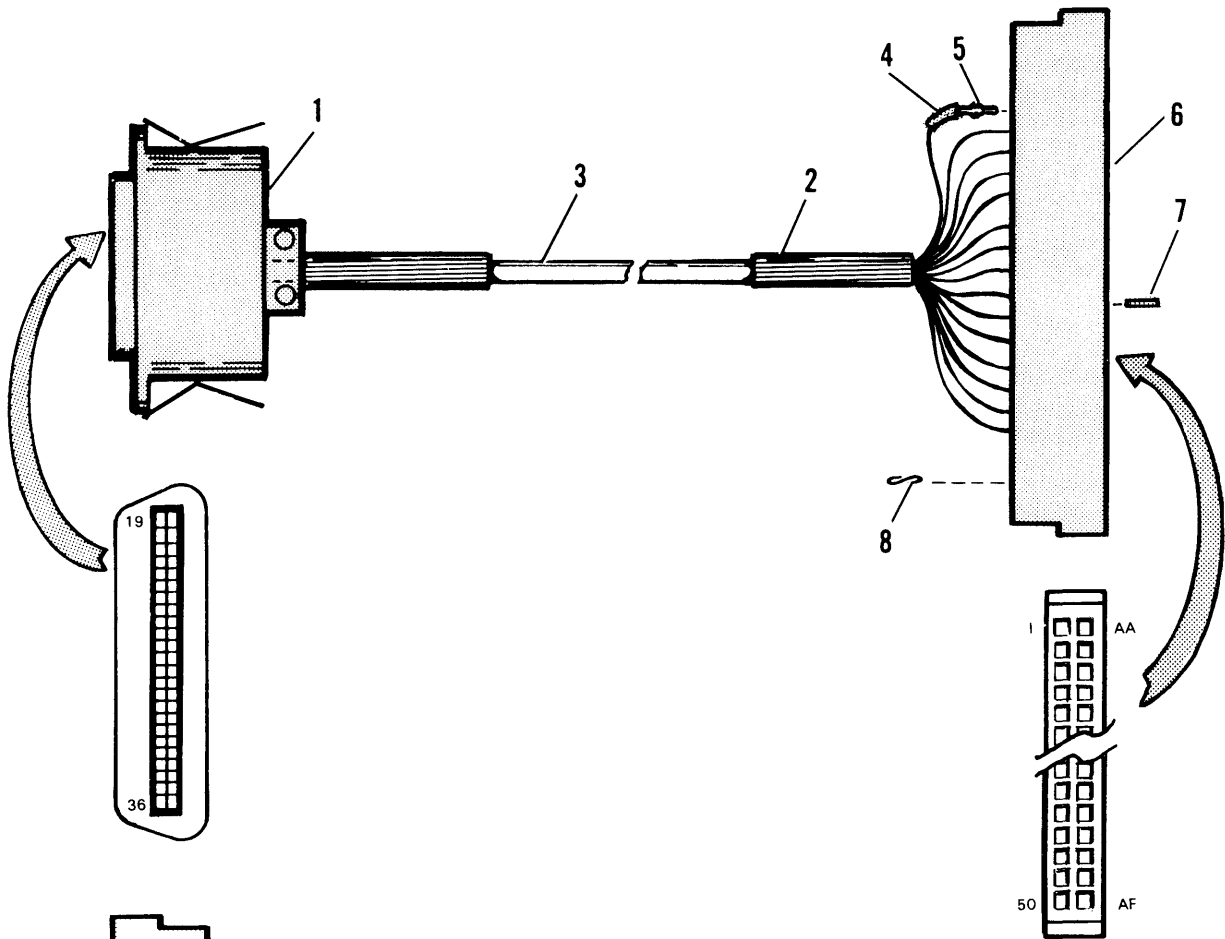

# CABLE I/O LP2 TO DCH CTL 820/1220

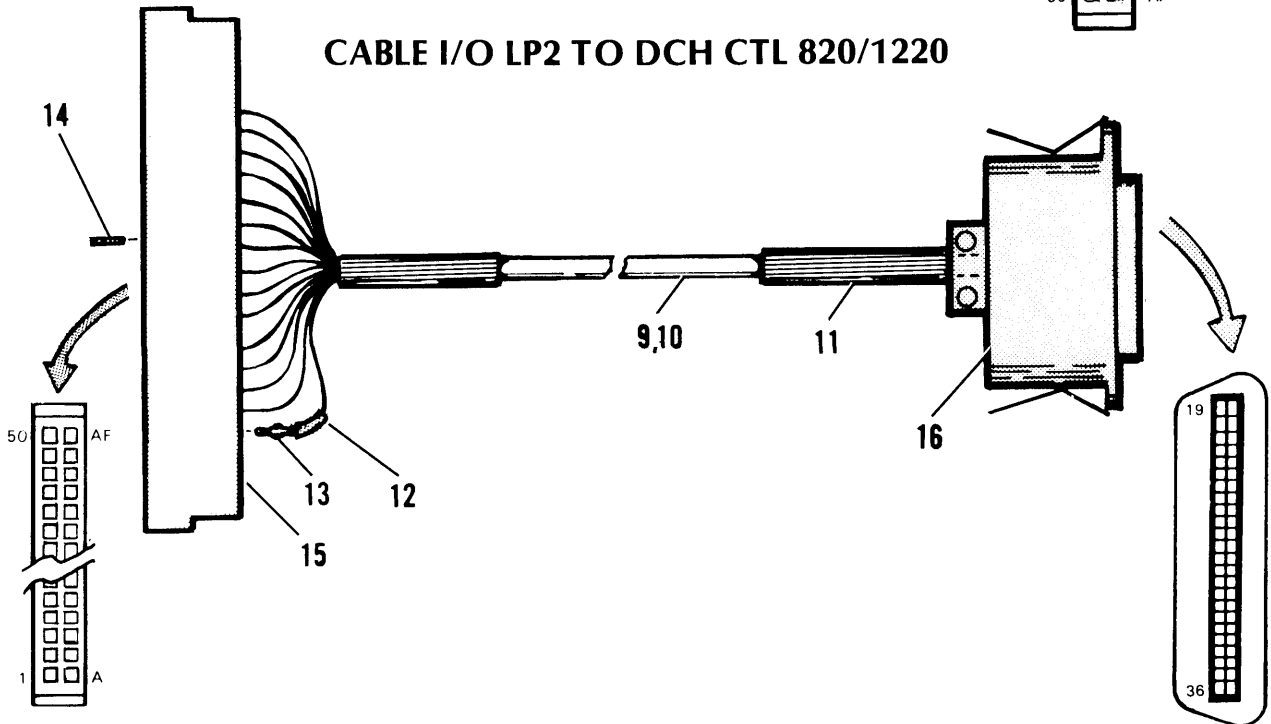

DG-04897

The drawings and parts lists contained herein are the property of DGC and shall neither be reproduced in whole or in part without DGC prior written approval nor be implied to grant any license to make, use, or sell equipment manufactured in accordance herewith.

PAGE & ITEM NO.	DESCRIPTION	QTY	DGC PART NO.	REF PAGE NO.
II-4	<b>CA EXT LINE PRINTER</b>	<b>1</b>	<b>005001356</b>	<b>I-2</b>
1	CONN AMP 57-30360	1	111000152	
2	TUBING 1/2 DIA HEAT SHRINK BLK	10	109000061	
3	CABLE 24 AWG 14 TW PR	25	109000062	
4	CONN CONTACT TWIN LEAF AMP 583616	21	111000115	
5	SLEEVING 3/32" HEAT SHRINK	11	109000098	
6	CONN PC EDGE 50 DUAL POS AMP1-583717-9	1	111000117	
7	CONN KEY AMP 583274	1	111000116	
8	CONN SPR RTNG AMP 583691-3	10	111000123	
II-4	<b>I/O CA LP2 TO DCH CTL 820/1220</b>		<b>005012099</b>	<b>I-2</b>
9	WIRE TERMINATION	1	029001401	
	WIRE 24 AWG 7/32 WHT	"3.00	109000049	
10	CABLE 24 AWG 19-COND 7 X 32	1	109000045	
11	TUBING 1/2 DIA HEAT SHRINK BLK	1	109000061	
12	SLEEVING 3/32" HEAT SHRINK	1	109000098	
13	CONN CONTACT TWIN LEAF AMP 583616	17	111000115	
14	CONN KEY AMP 583274	1	111000116	
15	CONN PC EDGE 50 DUAL POS AMP1-583717-9	1	111000117	
16	CONN AMP 57-30360	1	111000152	

The drawings and parts lists contained herein are the property of DGC and shall neither be reproduced in whole or in part without DGC prior written approval nor be implied to grant any license to make, use, or sell equipment manufactured in accordance herewith.

# CABLE, EXTERNAL LINE PRINTER-microNOVA

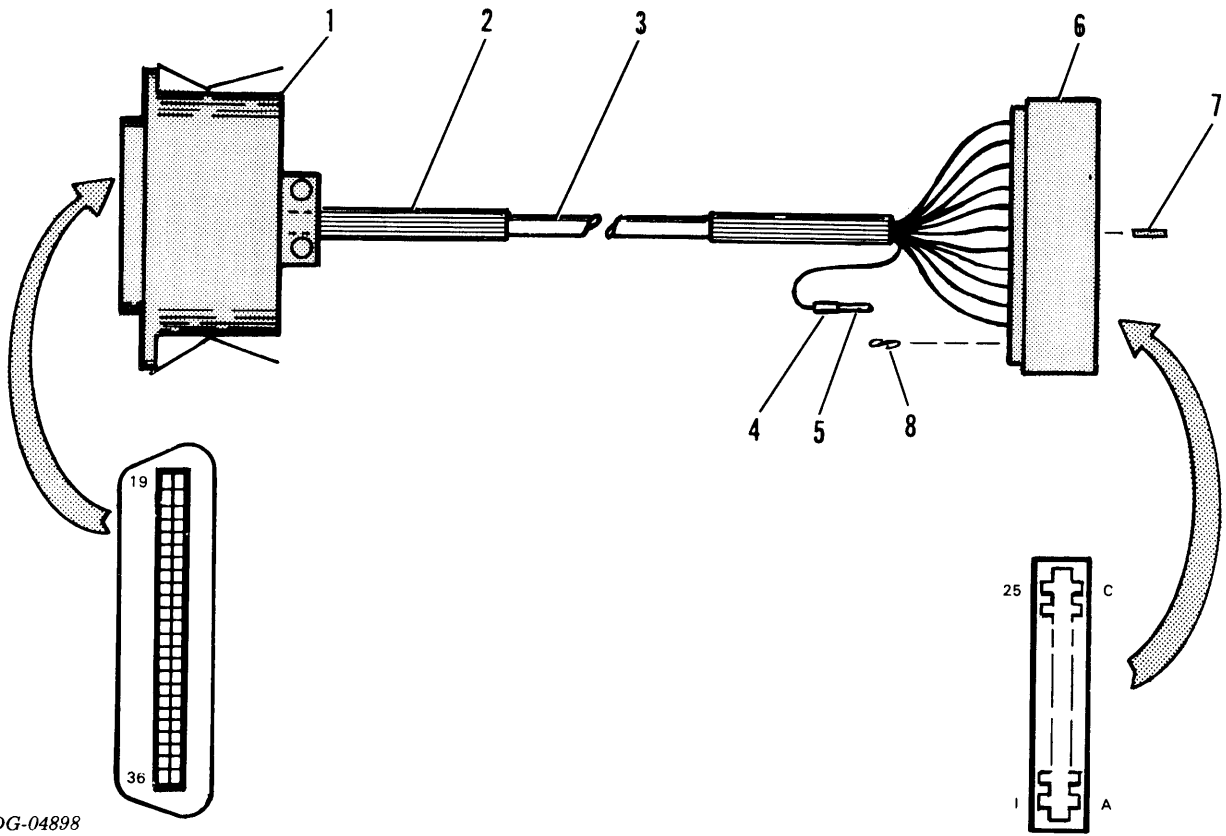

The drawings and parts lists contained herein are the property of DGC and shall neither be reproduced in whole or in part without DGC prior written approval nor be implied to grant any license to make, use, or sell equipment manufactured in accordance herewith.

PAGE & ITEM NO.	DESCRIPTION	QTY	DGC PART NO.	REF PAGE NO.
II-6	CABLE, EXTERNAL LINE PRINTER-microNOVA	1	005008452	I-2
1	CONN AMP 57-30360	1	111000152	
2	TUBING 1/2 DIA HEAT SHRINK BLK	1	109000061	
3	CABLE 24 AWG 14 TW PR	1	109000062	
4	SLEEVING 3/32" HEAT SHRINK	1	109000098	
5	CONN CONT TW LF 20-24AWG AMP 583853-2	22	111000343	
6	CONNECTOR CLIP ASSY MICRONOVA	1	002006622	
7	CONN KEY AMP 583274	1	111000116	
8	CONN SPR RTNG AMP 583691-3	6	111000123	

The drawings and parts lists contained herein are the property of DGC and shall neither be reproduced in whole or in part without DGC prior written approval nor be implied to grant any license to make, use, or sell equipment manufactured in accordance herewith.

# CABLE POWER CORD

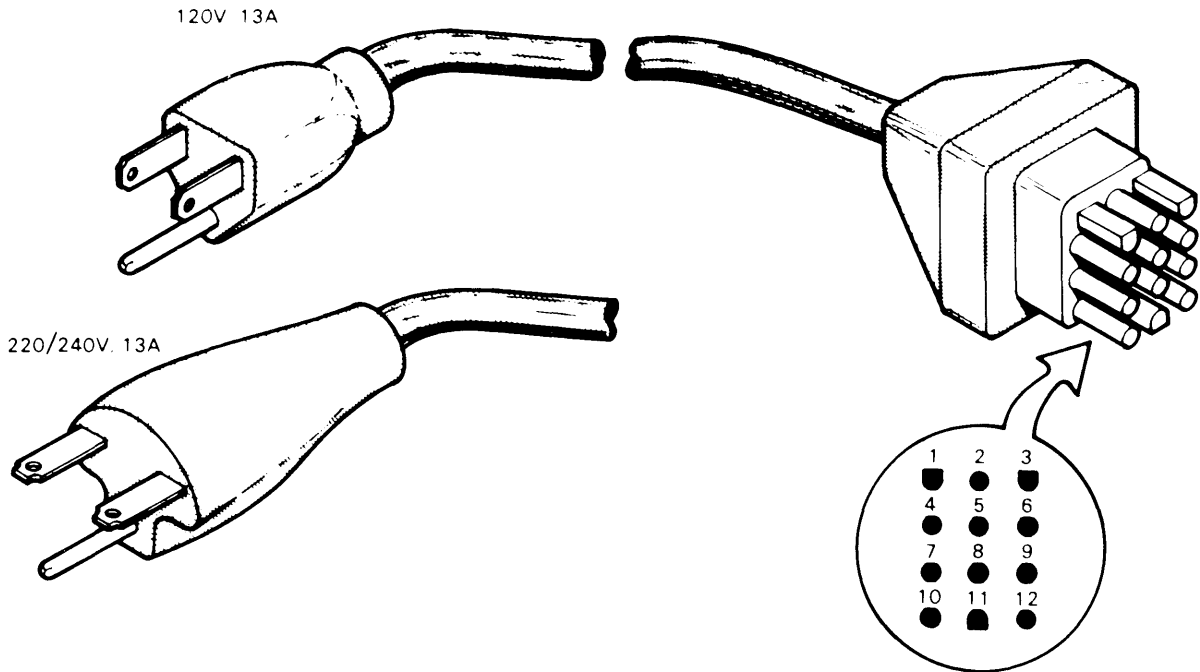

DG-04899

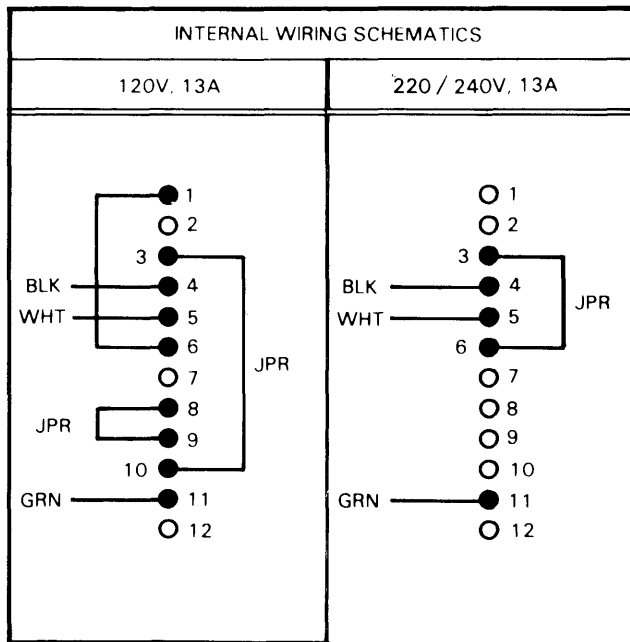

The drawings and parts lists contained herein are the property of DGC and shall neither be reproduced in whole or in part without DGC prior written approval nor be implied to grant any license to make, use, or sell equipment manufactured in accordance herewith.

PAGE & ITEM NO.	DESCRIPTION	QTY	DGC PART NO.	REF PAGE NO.
II-8 1 2	120V, 13A CABLE POWER CORD 240V, 13A CABLE POWER CORD	1 1	109-000238 109-000240	I-2

The drawings and parts lists contained herein are the property of DGC and shall neither be reproduced in whole or in part without DGC prior written approval nor be implied to grant any license to make, use, or sell equipment manufactured in accordance herewith.

# FORMS RECEIVER

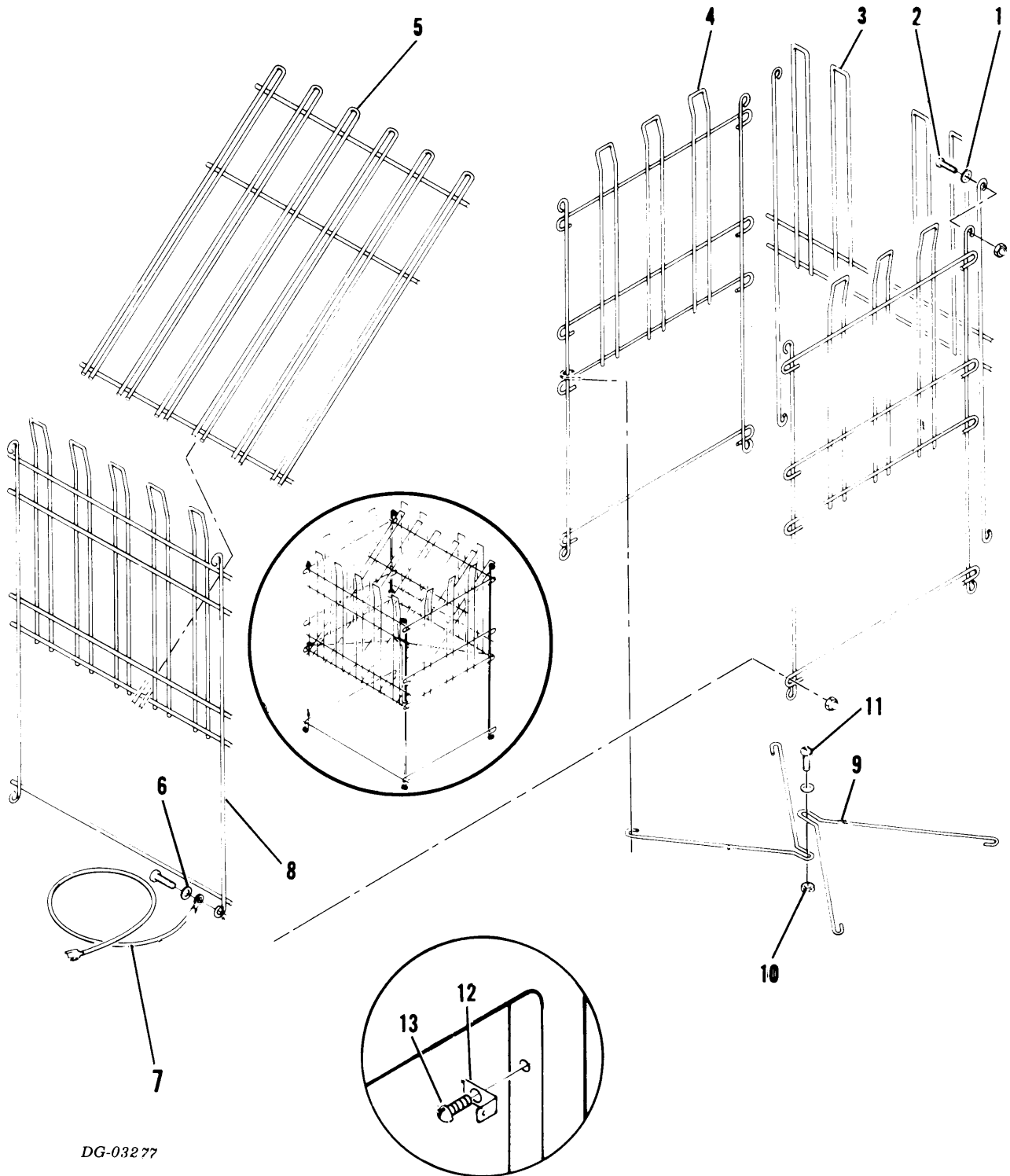

DG-03277

The drawings and parts lists contained herein are the property of DGC and shall neither be reproduced in whole or in part without DGC prior written approval nor be implied to grant any license to make, use, or sell equipment manufactured in accordance herewith.



PAGE & ITEM NO.	DESCRIPTION	QTY	DGC PART NO.	REF PAGE NO.
II-10	<b>RECEIVER FORMS</b>	1	<b>005007875</b>	1-2
1	WASHER FLAT SCDP 1/4	9	106000445	
2	SCR SLTD TRH SCDP 1/4-20 X 5/8	8	106000489	
3	REAR, RECEIVER, FORMS	1	002006020	
4	SIDE, RECEIVER, FORMS	2	002006018	
5	TRAY, FORMS	1	002006017	
6	WASHER INT. TOOTH 1/4	9	106000441	
	SHPG. MAT'L	REF	044000018	
7	<b>GND WIRE KIT FORMS RCVR.</b>	1	<b>005007870</b>	
8	FRONT, RECEIVER FORMS	1	002006019	
9	BRACE, CROSS	2	002006084	
10	NUT CAP SCDP 1/4-20	9	106000900	
11	SCR PHH PNH SCDP 1/4-20 X 12	1	106000547	
12	TERM TAB .250	1	111000787	
13	SCR PHH PNH SCDP SEMS 8-32 X 1/4	1	106000083	

The drawings and parts lists contained herein are the property of DGC and shall neither be reproduced in whole or in part without DGC prior written approval nor be implied to grant any license to make, use, or sell equipment manufactured in accordance herewith.



# **CHAPTER III MAIN ASSEMBLY**

# MAIN ASSEMBLY

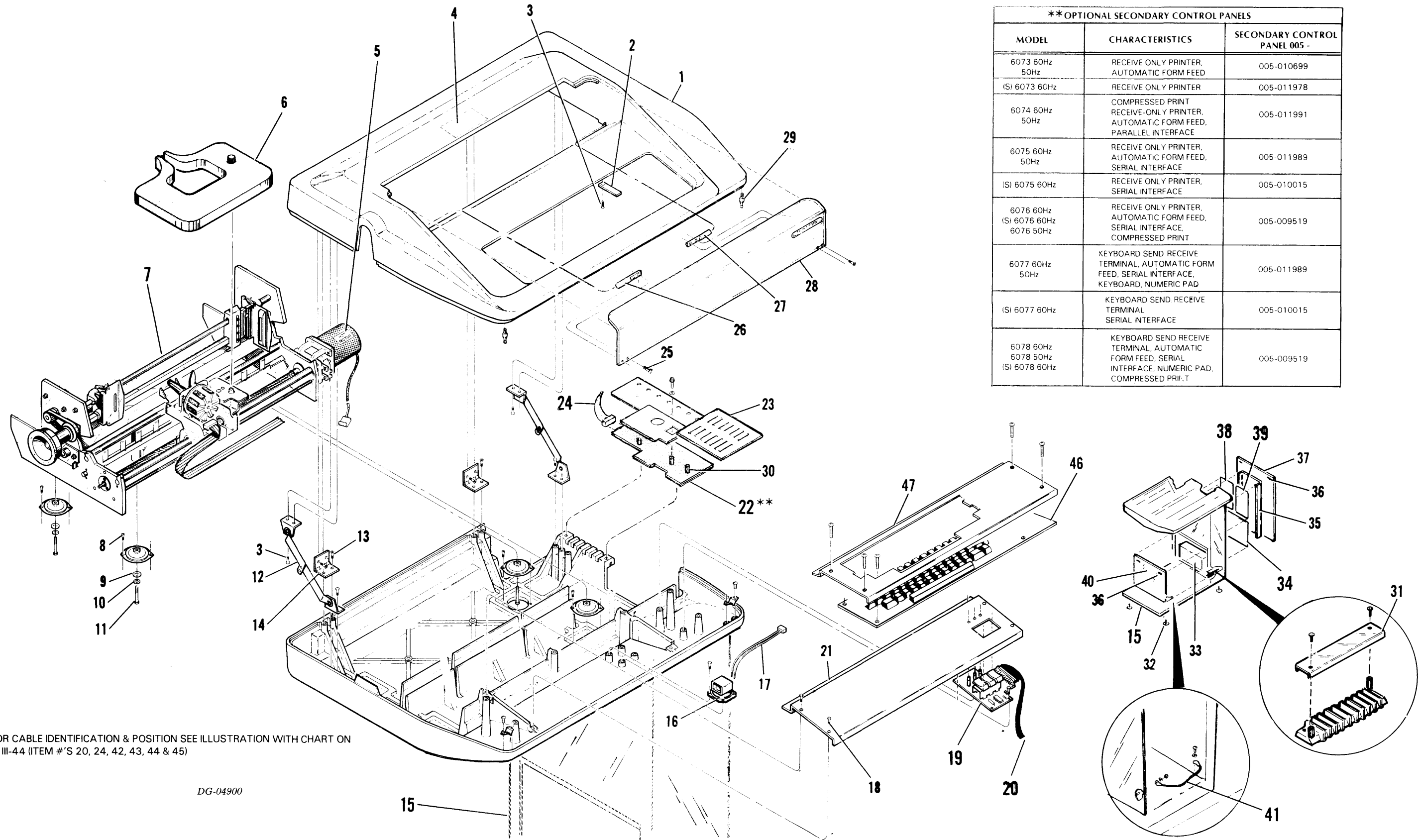

**OPTIONAL SECONDARY CONTROL PANELS		
MODEL	CHARACTERISTICS	SECONDARY CONTROL PANEL 005 -
6073 60Hz 50Hz	RECEIVE ONLY PRINTER, AUTOMATIC FORM FEED	005-010699
(S) 6073 60Hz	RECEIVE ONLY PRINTER	005-011978
6074 60Hz 50Hz	COMPRESSED PRINT RECEIVE ONLY PRINTER, AUTOMATIC FORM FEED, PARALLEL INTERFACE	005-011991
6075 60Hz 50Hz	RECEIVE ONLY PRINTER, AUTOMATIC FORM FEED, SERIAL INTERFACE	005-011989
(S) 6075 60Hz	RECEIVE ONLY PRINTER, SERIAL INTERFACE	005-010015
6076 60Hz (S) 6076 60Hz 6076 50Hz	RECEIVE ONLY PRINTER, AUTOMATIC FORM FEED, SERIAL INTERFACE, COMPRESSED PRINT	005-009519
6077 60Hz 50Hz	KEYBOARD SEND RECEIVE TERMINAL, AUTOMATIC FORM FEED, SERIAL INTERFACE, KEYBOARD, NUMERIC PAD	005-011989
(S) 6077 60Hz	KEYBOARD SEND RECEIVE TERMINAL SERIAL INTERFACE	005-010015
6078 60Hz 6078 50Hz (S) 6078 60Hz	KEYBOARD SEND RECEIVE TERMINAL, AUTOMATIC FORM FEED, SERIAL INTERFACE, NUMERIC PAD, COMPRESSED PRINT	005-009519

\* FOR CABLE IDENTIFICATION & POSITION SEE ILLUSTRATION WITH CHART ON PG. III-44 (ITEM #'S 20, 24, 42, 43, 44 & 45)

DG-04900

The drawings and parts lists contained herein are the property of DGC and shall neither be reproduced in whole or in part without DGC prior written approval nor be implied to grant any license to make, use, or sell equipment manufactured in accordance herewith.

PAGE & ITEM NO.	DESCRIPTION	QTY	DGC PART NO.	REF PAGE NO.
III-2	<b>MAIN 180 CPS R/O P/I</b>	1	005009583	III-2
1	TOP COVER SERIAL PRINTER	1	002004151	
2	SPRING, CLIP, WINDOW 30CPSKSR	2	002005530	
3	HEX WSHR HD PLASTITE SCDP 4-20X3/8	14	106000842	
4	LBL RIBBON CORRECT CTG	1	002007938	
5	LBL HOT MOTOR	1	002008174	
6	<b>RIBBON CARTRIDGE MECHANISM</b>	1	005009507	III-30
7	SCR PHH PNH SCDP SEMS 6-32X5/16	8	106000480	III-18
8	WSHR FLAT 1/4" .281X.625X.065SCDP	4	106000445	
9	WSHR INTL TOOTH SCDP 1/4	4	106000441	
10	SCR LSTD PNH SCDP 1/4-20X1	4	106000864	
11	STAY ASSY 30 CPS PTR	2	002005617	
12	SLTD FLH PLASTITE BLK OXD 4-20X3/8	8	106000841	
13	HINGE, CVR, MOD 30CPS KSR	2	002005526	
14	<b>PEDESTAL</b>	1	005009502	III-12
15	MIN PM SPEAKER 11/2" .05W#99-6035	1	123000427	
16	<b>CONTROL LOGIC TO BELL CABLE</b>	1	005009576	III-4 III-42
17	SCR SLTD PNH NYL WHT 6-32X1/4	4	106000212	
18	<b>CONTROL PANEL PCB TESTED SER PTR</b>	1	005006407	
	I.P.L. CONT. PNL. P.C.B.	REF	016000339	
	SCHEMATIC	REF	001001007	
	ARTWORK	REF	107000636	
* 20	<b>CONTROL LOGIC TO CONTROL PNL CBL</b>	1	005009582	III-10 III-42
21	PNL, FLR 30CPS PTR	1	002008342	
** 22	<b>SECONDARY CONTROL PCB</b>	1	005009519	
	I.P.L. SEC. CONT. P.C.B.	REF	016000543	
	SCHEMATIC	REF	001001224	
	ARTWORK	REF	107000922	
23	CVR SEC CONTROL PNL	1	002007435	
* 24	<b>CONTROL LOGIC TO SEC CONTROL CBL</b>	1	005009581	III-8 III-42
25	SCR PHH FLH SCDP 4-40X5/16	4	106000129	
26	PIVOT PIN, LH, WINDOW 30CPS	1	002005528	
27	PIVOT PIN, RH, WINDOW 30CPS	1	002005529	
28	WINDOW, P2	1	002008173	
29	BALL STUD PI 16-525-6	2	123001005	
30	HEX SPACER, .50 LONG	3	123001182	
31	CVR TERM BLOCK	1	002007440	
32	LEG LEVELER, ADJUSTABLE FA2720	4	123000970	
33	SHIELD HIGH VOLTAGE	1	002007436	
34	<b>CONTROL LOGIC PCB LP-2</b>	1	005009503	III-43
	I.P.L. CONT. LOGIC P.C.B.	REF	016000541	
	SCHEMATIC	REF	001001220	
	ARTWORK	REF	107000897	
35	CVR HIGH VOLTAGE	1	002007352	
36	NYLATCH 1/4T .057 PNL HRN6-2-2	4	123001018	
37	PNL, MAIN 30CPS PTR	1	002004181	
38	<b>DRIVER PCB</b>	1	005009505	III-43
	I.P.L. DRIVER P.C.B.	REF	016000540	
	SCHEMATIC	REF	001001226	
	ARTWORK	REF	107000832	
39	<b>P/S PCB LP-2</b>	1	005009514	III-43
	I.P.L. P/S P.C.B.	REF	016000542	
	SCHEMATIC	REF	001001223	
	ARTWORK	REF	107000886	

PAGE & ITEM NO.	DESCRIPTION	QTY	DGC PART NO.	REF PAGE NO.
40	PNL, P/S 300P5 PTR	1	002004182	
41	GND WIRE KIT 30CPS SER PTR	1	005007869	III-4
* 42	DRIVER TO CONTROL LOGIC CBL	1	005009580	II-8 III-42
* 43	P/S TO CONTROL LOGIC CABLE	1	005009578	III-6 III-42
* 44	P/S TO DRIVER CABLE	1	005009579	III-6 III-42
* 45	CONTROL TO PAR I/O CABLE	1	005009596	III-10 III-42
	<b>OPTIONAL ITEMS (TP-2)</b>			
46	STANDARD KEYBOARD	1	118000677	I-2
47	COVER PANEL STANDARD	1	002006170	
	NUMERIC KEYBOARD (NOT SHOWN)	1	118000676	
	COVER PANEL NUMERIC (NOT SHOWN)	1	002006171	
	LABEL DASHER P/2	1	002008222	
	LABEL MODEL S/N	1	002008223	
	TERM BUSHING	1	111000753	
	KED NUT #8-32	1	106000255	
	WASHER FLAT #8	1	106000264	
	PANEL FILLER	1	002008342	
	Information Not Available			
	* SEE ILLUSTRATION PAGE III-2			
	** FOR ADDITIONAL SECONDARY CONTROL P.C.B. OPTIONS SEE TABLE III-2			

The drawings and parts lists contained herein are the property of DGC and shall neither be reproduced in whole or in part without DGC prior written approval nor be implied to grant any license to make, use, or sell equipment manufactured in accordance herewith.

The drawings and parts lists contained herein are the property of DGC and shall neither be reproduced in whole or in part without DGC prior written approval nor be implied to grant any license to make, use, or sell equipment manufactured in accordance herewith.

**GROUND WIRE KIT  
& CONTROL LOGIC TO BELL CABLE**

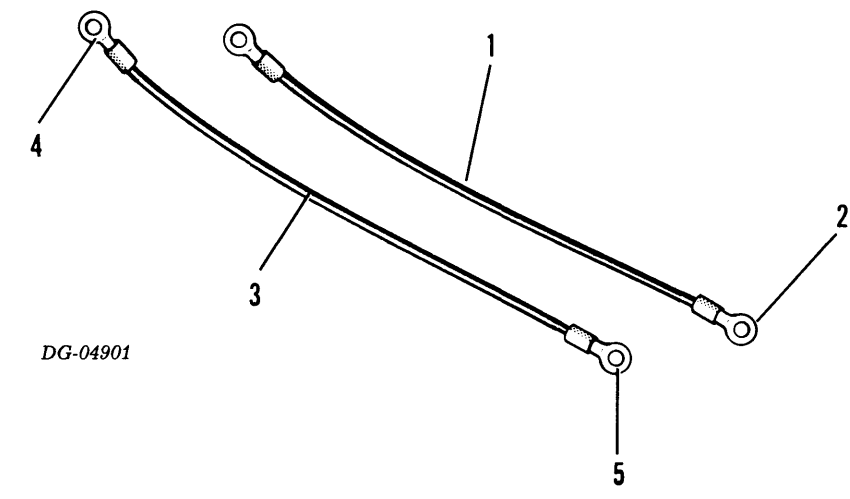

DG-04901

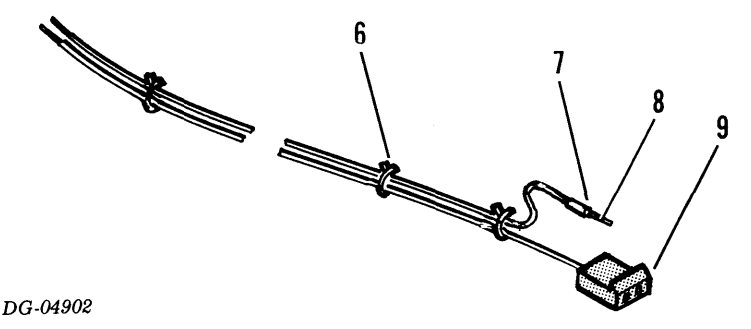

DG-04902

The drawings and parts lists contained herein are the property of DGC and shall neither be reproduced in whole or in part without DGC prior written approval nor be implied to grant any license to make, use, or sell equipment manufactured in accordance herewith.

PAGE & ITEM NO.	DESCRIPTION	QTY	DGC PART NO.	REF PAGE NO.
III-4				
	<b>GROUND WIRE KIT</b>	1	<b>005007869</b>	III-2
1	WIRE TERMINATION	1	029000353	
	WIRE #14 AWG GRN	1	109000031	
2	TERM RING #10 STUD	2	111000035	
3	WIRE TERMINATION	1	029002213	
	WIRE #14AWG GRN	1	109000031	
4	TERM RING #10 STUD	1	111000035	
5	TERM RING #6 STUD	1	111000140	
III-4				
	<b>CONTROL LOGIC TO BELL CABLE</b>	1	<b>005009576</b>	III-2 III-42
6	SSTIM 3/4	13	123000025	
7	SLEEVING 3/32 HEAT SHRINK	1	109000098	
8	TERM 18-24 AWG	2	111000578	
9	CONN. P.C.B.	1	111000562	

The drawings and parts lists contained herein are the property of DGC and shall neither be reproduced in whole or in part without DGC prior written approval nor be implied to grant any license to make, use, or sell equipment manufactured in accordance herewith.

**POWER SUPPLY TO CONTROL LOGIC CABLE  
& POWER SUPPLY TO DRIVER CABLE**

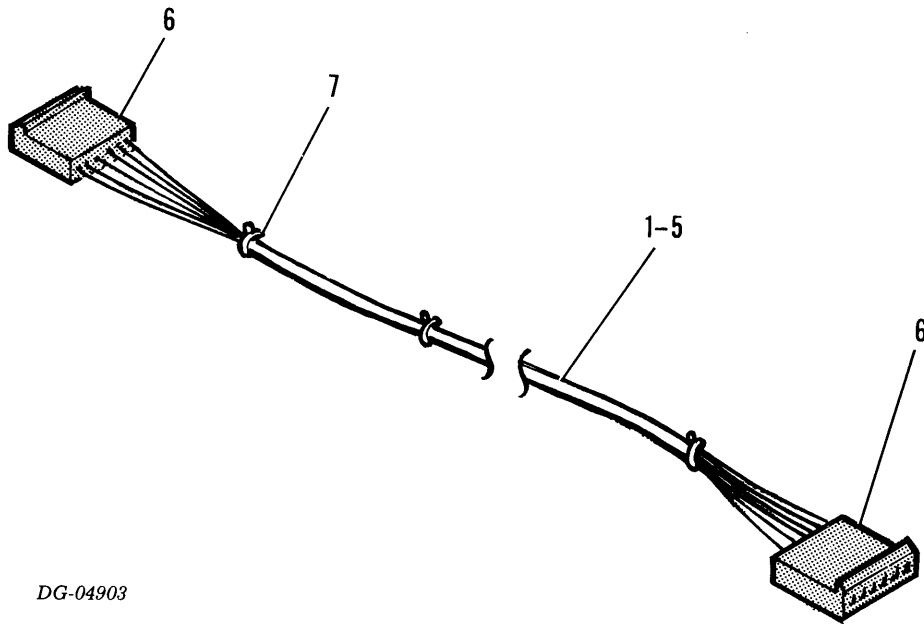

DG-04903

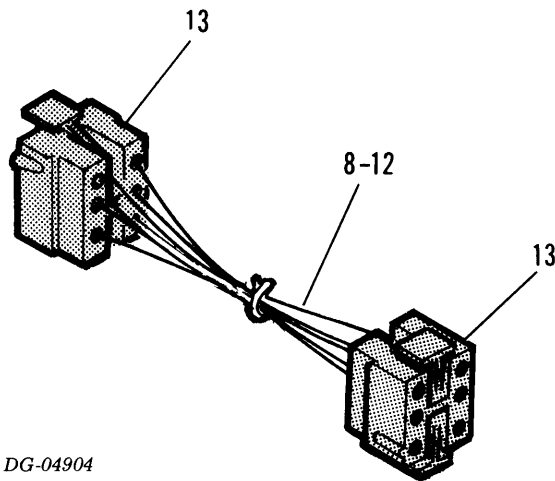

DG-04904



PAGE & ITEM NO.	DESCRIPTION	QTY	DGC PART NO.	REF PAGE NO.
<b>III-6</b>	<b>P/S TO CONTROL LOGIC CABLE</b>	<b>1</b>	<b>005009578</b>	<b>III-2 III-42</b>
1	WIRE TERMINATION	1	029002986	
	WIRE 22AWG 19X34	1	109000035	
	TERM 18X24AWG	2	111000578	
2	WIRE TERMINATION	1	029002987	
	WIRE 22AWG 19X34 BLU	1	109000012	
	TERM 18X24 AWG	2	111000578	
3	WIRE TERMINATION	1	029002988	
	WIRE 22AWG 19X34 WHT	1	109000015	
	TERM 18X24 AWG	2	111000578	
4	WIRE TERMINATION	1	029002989	
	WIRE 22AWG 19X34 BLK	1	109000016	
	TERM 18X24 AWG	1	111000578	
5	WIRE TERMINATION	1	029002990	
	WIRE 22AWG 19X34 ORN	1	109000013	
	TERM 18X24 AWG	2	111000578	
6	CONNECTOR P.C.B.	2	111000565	
7	SSTIM 3/4	3	123000025	
	WIRE TERMINATION	1	029002985	
<b>III-6</b>	<b>P/S TO DRIVER CABLE</b>	<b>1</b>	<b>005009579</b>	<b>III-2 III-42</b>
8	WIRE TERMINATION	1	029002979	
	WIRE #14AWG WHT	1	109000029	
	CONN 20-14 TIN PIN	2	111000285	
9	WIRE TERMINATION	1	029002980	
	WIRE #14AWG BLUE	1	109000032	
	CONN 20-14 TIN PIN	2	111000285	
10	WIRE TERMINATION	1	029002981	
	WIRE #14AWG ORN	1	109000033	
	CONN 20-14 TIN PIN	2	111000285	
11	WIRE TERMINATION	1	029002982	
	WIRE #14AWG YEL	1	109000034	
	CONN 20-14 TIN PIN	2	111000285	
12	WIRE TERMINATION	1	029002983	
	WIRE #18AWG WHT	2	109000015	
	CONN 20-14 TIN PIN	2	111000285	
13	CONN SKT HSG 6 PIN	2	111000518	

The drawings and parts lists contained herein are the property of DGC and shall neither be reproduced in whole or in part without DGC prior written approval nor be implied to grant any license to make, use, or sell equipment manufactured in accordance herewith.

DRIVER TO CONTROL LOGIC CABLE  
CONTROL LOGIC TO SECONDARY CONTROL CABLE

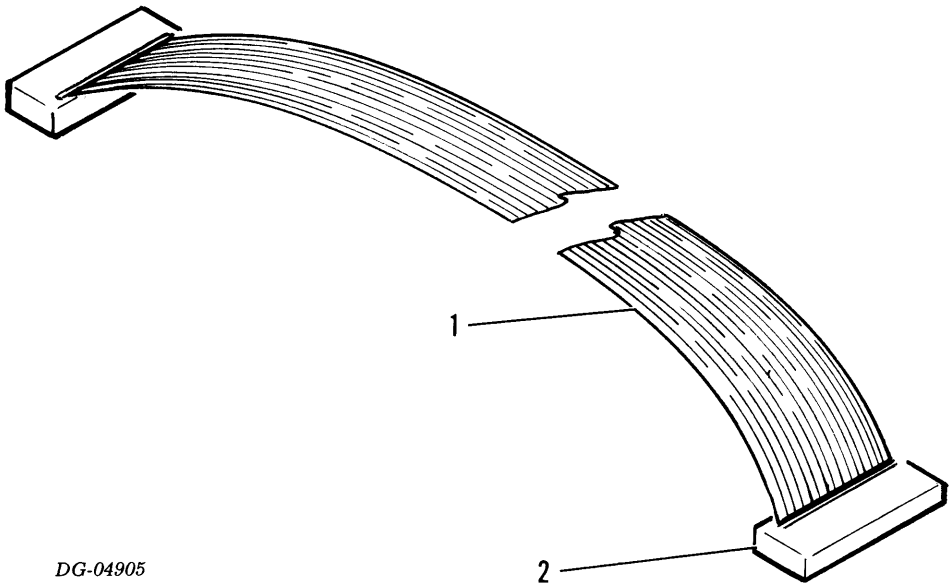

DG-04905

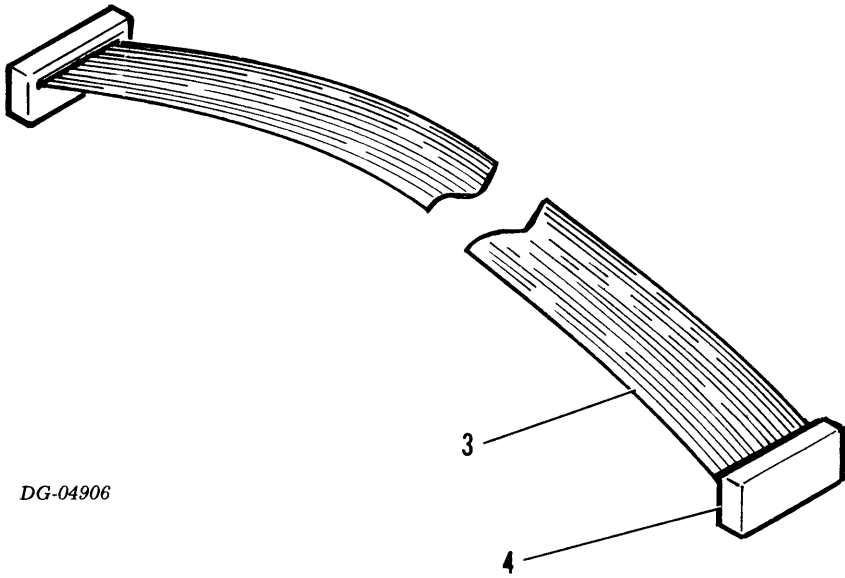

DG-04906

The drawings and parts lists contained herein are the property of DGC and shall neither be reproduced in whole or in part without DGC prior written approval nor be implied to grant any license to make, use, or sell equipment manufactured in accordance herewith.

PAGE & ITEM NO.	DESCRIPTION	QTY	DGC PART NO.	REF PAGE NO.
III-8	<b>DRIVER TO CONTROL LOGIC CABLE</b>	1	<b>005009580</b>	III-2 III-42
1	CABLE RIBBON 34 COND.	1	109000173	
2	CONN 34 PIN	2	111000883	
	<b>CONTROL LOGIC TO SEC CONTROL CABLE</b>	1	<b>005009581</b>	III-2 III-42
3	WIRE 20 COND 28AWG STRAND	1	109000208	
4	CONN 20 PIN	2	111000884	

The drawings and parts lists contained herein are the property of DGC and shall neither be reproduced in whole or in part without DGC prior written approval nor be implied to grant any license to make, use, or sell equipment manufactured in accordance herewith.

# CONTROL LOGIC TO CONTROL PANEL CABLE & CONTROL TO PAR I/O CABLE

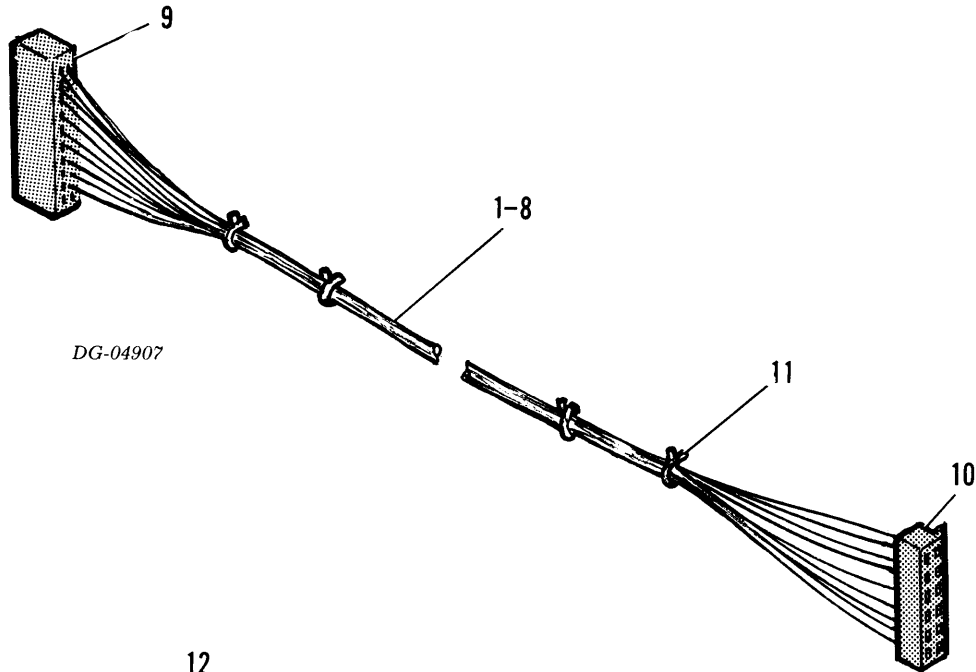

DG-04907

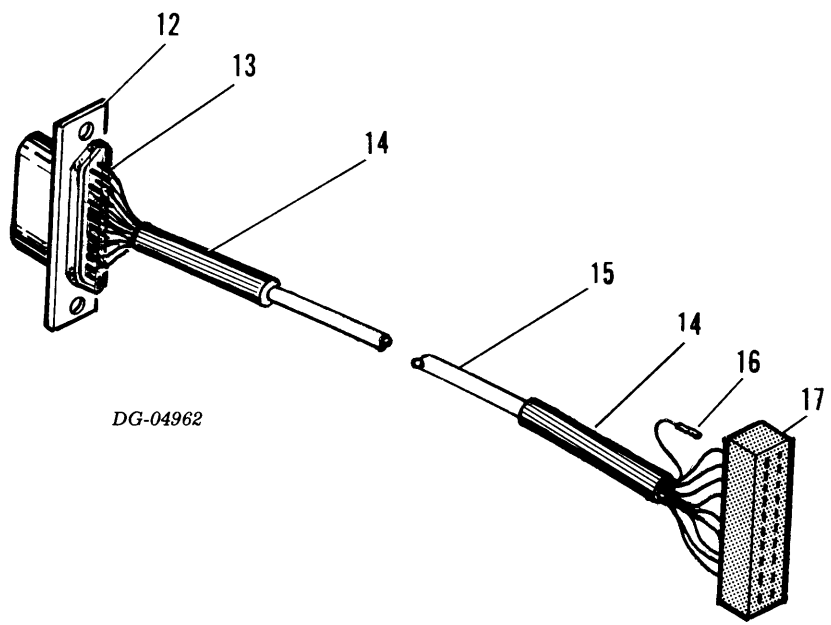

DG-04962

The drawings and parts lists contained herein are the property of DGC and shall neither be reproduced in whole or in part without DGC prior written approval nor be implied to grant any license to make, use, or sell equipment manufactured in accordance herewith.

PAGE & ITEM NO.	DESCRIPTION	QTY	DGC PART NO.	REF PAGE NO.
III-10	<b>CONTROL LOGIC TO CONTROL PNL CABLE</b>	<b>1</b>	<b>005009582</b>	<b>III-2 III-42</b>
1	WIRE TERMINATION	1	029002999	
	WIRE #22 AWG 19X34 RED	1	109000008	
	CONN. 24-20 AWG	1	111000058	
	TERM 18X24 AWG	1	111000578	
2	WIRE TERMINATION	1	029003001	
	WIRE 22 AWG 19X34 VIO.	1	109000066	
	CONN 24-20 AWG	1	111000058	
	TERM 18X24 AWG	1	111000578	
3	WIRE TERMINATION	1	029003002	
	WIRE #22 AWG 19X34 GRN	1	109000011	
	CONN 24-20 AWG	1	111000058	
	TERM 18-24 AWG	1	111000578	
4	WIRE TERMINATION	1	029003003	
	WIRE 22 AWG 19X34 BLUE	1	109000012	
	CONN 20-24 AWG	1	111000058	
	TERM 18-24 AWG	1	111000578	
5	WIRE TERMINATION	1	029003004	
	WIRE 22 AWG 19X34 ORN	1	109000013	
	CONN 20-24 AWG	1	111000058	
	TERM 18-24 AWG	1	111000578	
6	WIRE TERMINATION	1	029003005	
	WIRE 22 AWG 19X34 YEL.	1	109000035	
	CONN 20-24 AWG	1	111000058	
	TERM 18-24 AWG	1	111000578	
7	WIRE TERMINATION	1	029003006	
	WIRE 22AWG 19X34 GRY	1	109000063	
	CONN 20-24 AWG	1	111000058	
	TERM 18-24 AWG	1	111000578	
8	WIRE TERMINATION	1	029003007	
	WIRE 22 AWG 19X34 BRN	1	109000064	
	CONN 24-20 AWG	1	111000058	
	TERM 18-24 AWG	1	111000578	
9	CONN CABLE 20 DUAL POSITION	1	111000027	
10	CONN 12 PIN CRIMP TYPE	1	111000564	
11	SSTIM 3/4	9	123000025	
III-10	<b>CONTROL TO PAR I/O CABLE</b>	<b>1</b>	<b>005009596</b>	<b>III-2 III-42</b>
12	CONN 36 PIN	1	111000886	
13	SLEEVING 3/32" HEAT SHRINK	1	109000098	
14	TUBING 1/2 DIA HEAT SHRINK BLK	1	109000061	
15	CABLE 24AWG 19-COND 7X32	1	109000045	
16	CONN AMP 85969-2 CRP 24-20 AWG	19	111000058	
17	CONN CABLE 20 DUAL POS AMP 86148-1	1	111000027	

The drawings and parts lists contained herein are the property of DGC and shall neither be reproduced in whole or in part without DGC prior written approval nor be implied to grant any license to make, use, or sell equipment manufactured in accordance herewith.

PEDESTAL

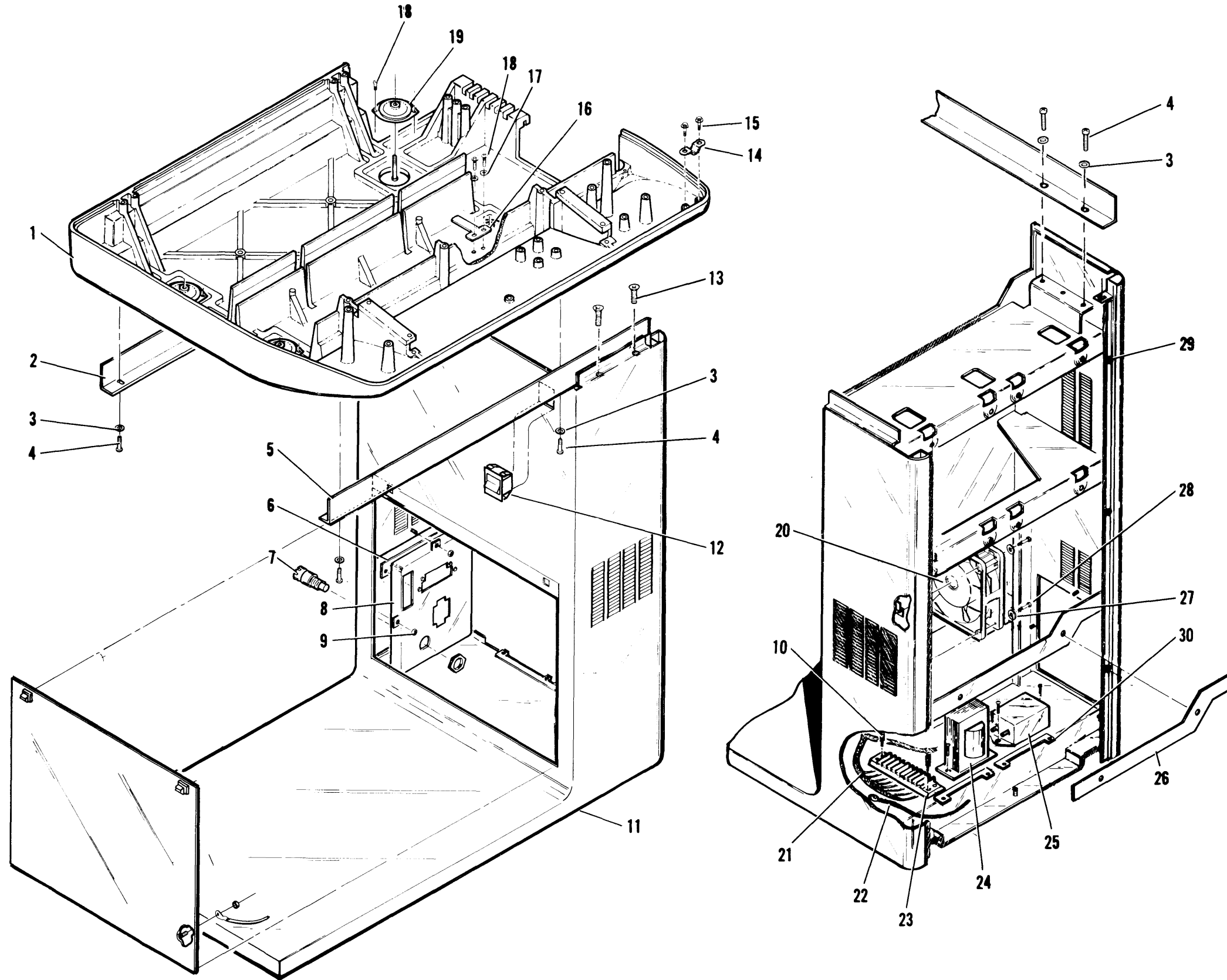

DG-04908

The drawings and parts lists contained herein are the property of DGC and shall neither be reproduced in whole or in part without DGC prior written approval nor be implied to grant any license to make, use, or sell equipment manufactured in accordance herewith.

PAGE & ITEM NO.	DESCRIPTION	QTY	DGC PART NO.	REF PAGE NO.
III-12	<b>PEDESTAL</b>	1	005009502	III-2
1	BASE COVER SERIAL PRINTER	1	002004150	
2	ANGLE, REAR 30CPS PTR	1	002004166	
3	WSHR FLAT #10 .219X.500X.049 SCDP	6	106000263	
4	SCR PHH PNH SCDP SEM 10-32X1/2	6	106000108	
5	ANGLE FRONT	1	002007407	
6	COVER PLATE	1	002007420	
7	CIRCUIT BREAKER 5 A.	1	113000168	
8	PNL, INLET	1	002007405	
9	NUT HEX KEP SCDP 4-40	3	106000257	
10	THREADED SPACER	2	002007449	
11	PEDESTAL WELDMENT	1	002007418	
12	SWITCH DPOT 15/125 10/250 TGD0511-T88	1	110000226	
13	SCR PHH FLH SCDP 10-32X3/8	2	106000174	
14	STUD REC #C1663-012-27	2	123000132	
15	HEX WSHR HD PLASTITE SCDP 4-20X3/8	4	106000842	
16	CLIP CABLE	1	002006131	
17	WSHR FLAT #6 .156X.375X.049 SCDP	2	106000461	
18	SCR PHH PNH SCDP SEMS 6-32X5/16	8	106000480	
19	SHOCK MOUNT 150-PD-10	4	123000972	
20	FAN	1	115000151	
21	<b>P/S HARNESS</b>	1	005009516	III-14
22	GND WIRE	1	029002926	
23	TERM BLOCK 10POS KULKA #600-10-UH	1	111000754	
24	<b>XFMR</b>	1	005009523	III-16
25	CAP LINE FILTER EMI PWR 10R6 10A	1	103000288	
26	INSULATOR PCB	1	002007442	
27	WSHR INTL TOOTH SCDP #6	3	106000455	
28	SCR SLTD BDGH SCDP 6-32X1 1/2	3	106000305	
29	BUTTON BUMPER 3265	6	123000971	
30	CARD GUIDE	2	123001274	
	TERM R TNG #10STUD 16-14 AMP 2-31903-2	2	111000035	
	TERM R TNG #8STUD 22-16 AMP 2-31886-2	8	111000141	
	TERM RCPT 110 22-18AWG AMP 61048-2	2	111000206	
	TERM RCPT 187 22-18AWG 509774-T1	4	111000586	
	TERM RCPT 250 22-18AWG 509778	2	111000588	
	TERM RCPT 110SER 22-18AWG 509770-T1	2	111000589	
	TERM INSUL SPRING SPADE #18-22AWG	9	111000680	
	CONN JUMPER 2 POS 422-13-11-026	2	111000697	
	} INFORMATION NOT AVAILABLE			

The drawings and parts lists contained herein are the property of DGC and shall neither be reproduced in whole or in part without DGC prior written approval nor be implied to grant any license to make, use, or sell equipment manufactured in accordance herewith.

# POWER SUPPLY HARNESS

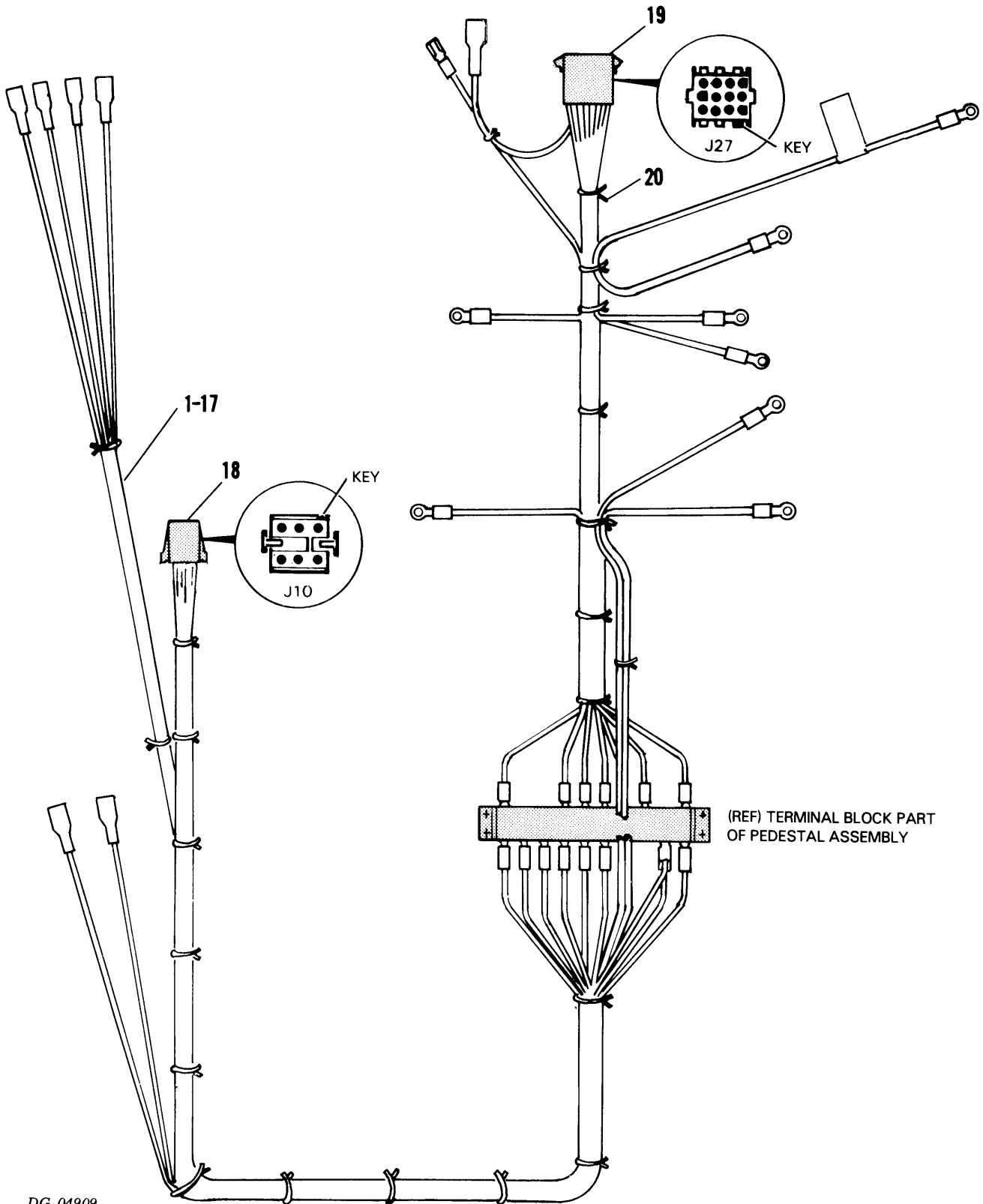

DG-04909

The drawings and parts lists contained herein are the property of DGC and shall neither be reproduced in whole or in part without DGC prior written approval nor be implied to grant any license to make, use, or sell equipment manufactured in accordance herewith.



PAGE & ITEM NO.	DESCRIPTION	QTY	DGC PART NO.	REF PAGE NO.
III-14	<b>POWER SUPPLY HARNESS</b>		<b>005009516</b>	III-12 III-42
1	WIRE TERMINATION WIRE #18 AWG YEL #6 SPRING SPADE LUG PIN, TERM, AMP	1 16" 1 1	029003259 109000020 111000680 111000702	
2	WIRE TERMINATION WIRE #14 GRN RING LUG #10 PIN, TERM, AMP	1 8" 1 1	029003260 109000031 111000035 111000702	
3	WIRE TERMINATION WIRE #18 AWG BLU #8 RING LUG #6 SPRING SPADE LUG	1 10" 1 1	029003261 109000018 111000141 111000680	
4	WIRE TERMINATION WIRE #18 AWG BRN TERM 250 FASTON #8 RING LUG	1 8" 1 1	029003262 109000131 111000033 111000141	
5	WIRE TERMINATION WIRE #18 AWG V10 #6 SPRING SPADE LUG PIN, MATE-N-LOCK	1 28 1/2 1 1	029003263 109000132 111000680 111000774	
6	WIRE TERMINATION WIRE #18 AWG WHT #6 SPRING SPADE LUG PIN, TERM, AMP	1 14 1/2 1 1	029003264 109000015 111000680 111000703	
7	WIRE TERMINATION WIRE 18 AWG BLU #6 SPRING SPADE LUG PIN, TERM, AMP	1 14 1/2 1 1	029003265 109000018 111000680 111000703	
8	WIRE TERMINATION WIRE #18 AWG WHT FASTON .187 PIN, TERM, AMP	1 5 1/2 1 1	029003266 109000015 111000588 111000703	
9	WIRE TERMINATION WIRE #18 AWG RED #10 RING LUG PIN, TERM, AMP	1 7 1/2 1 1	029003267 109000014 111000036 111000703	
10	WIRE TERMINATION WIRE #18 AWG ORN. #6 SPRING SPADE LUG PIN, TERM, AMP	1 14 1/2 1 1	029003268 109000019 111000680 111000703	
11	WIRE TERMINATION WIRE #18 AWG BRN #6 SPRING SPADE LUG PIN, MATE-N-LOCK	1 28 3/8 1 1	029003269 109000131 111000680 111000774	
12	WIRE TERMINATION WIRE #18 AWG WHT #6 SPRING SPADE LUG PIN MATE-N-LOCK	1 28 3/4 1 1	029003270 109000015 111000680 111000774	
13	WIRE TERMINATION WIRE #14 AWG GRN #10 RING LUG PIN MATE-N-LOCK	1 38 3/4 1 1	029003271 109000031 111000035 111000774	
14	WIRE TERMINATION WIRE #18 AWG BLU FASTON .250 #6 SPRING SPADE	1 36" 1 1	029003272 109000018 111000588 111000680	
15	WIRE TERMINATION WIRE #18 AWG WHT FASTON 250 #6 SPRING SPADE LUG	1 36 1/2 1 1	029003273 109000015 111000588 111000630	

The drawings and parts lists contained herein are the property of DGC and shall neither be reproduced in whole or in part without DGC prior written approval nor be implied to grant any license to make, use, or sell equipment manufactured in accordance herewith.

PAGE & ITEM NO.	DESCRIPTION	QTY	DGC PART NO.	REF PAGE NO.
16	WIRE TERMINATION WIRE #18 AWG ORN #10 RING LUG FASTON .250	1 47" 1 1	029003275 109000019 111000036 111000588	
17	WIRE TERMINATION WIRE #18 AWG ORN FASTON .250 #6 SPRING SPADE LUG	1 37" 1 1	029003276 109000019 111000588 111000680	
18	CONNECTOR	1	111000518	
19	CONNECTOR	1	111000703	
20	TYWRAP	24	123000025	

The drawings and parts lists contained herein are the property of DGC and shall neither be reproduced in whole or in part without DGC prior written approval nor be implied to grant any license to make, use, or sell equipment manufactured in accordance herewith.

# TRANSFORMER & TRANSFORMER JUMPER WIRE KIT

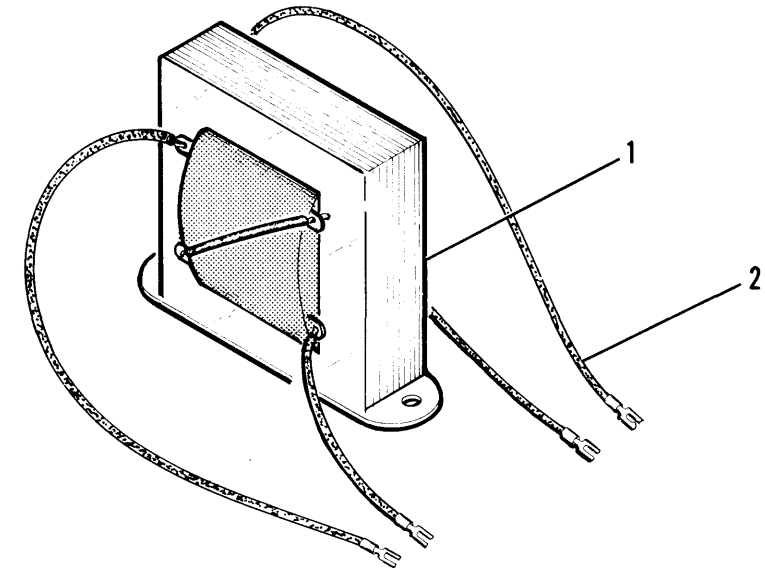

DG-04910

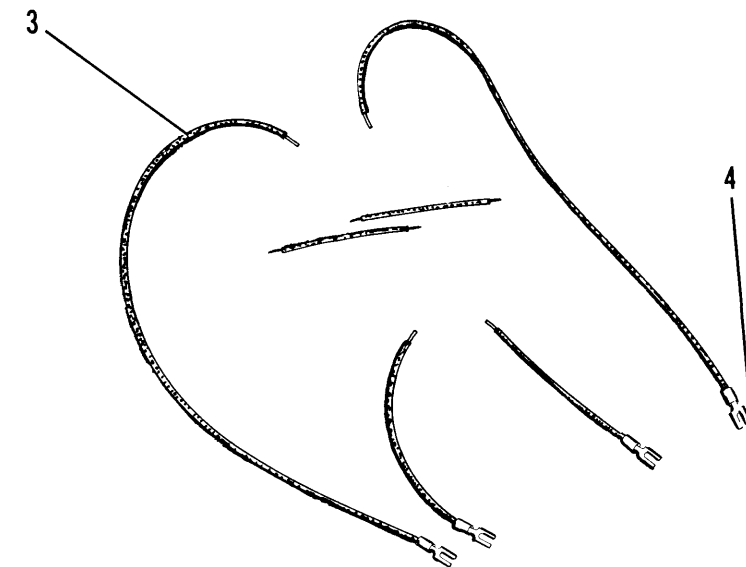

DG-04911

PAGE & ITEM NO.	DESCRIPTION	QTY	DGC PART NO.	REF PAGE NO.
III-16				
1	XFMR	1	005009523	III-12
2	XFMR JUMPER WIRE KIT	1	005009524	
	XFMR F 106Z	1	104000014	
	TRANSFORMER JUMPER WIRE KIT	1	005009524	
3	WIRE #18 AWG 19X30 WHT	1	109000015	
4	TERM INSUL SPRING SPADE	6	111000680	

The drawings and parts lists contained herein are the property of DGC and shall neither be reproduced in whole or in part without DGC prior written approval nor be implied to grant any license to make, use, or sell equipment manufactured in accordance herewith.

MECHANISM

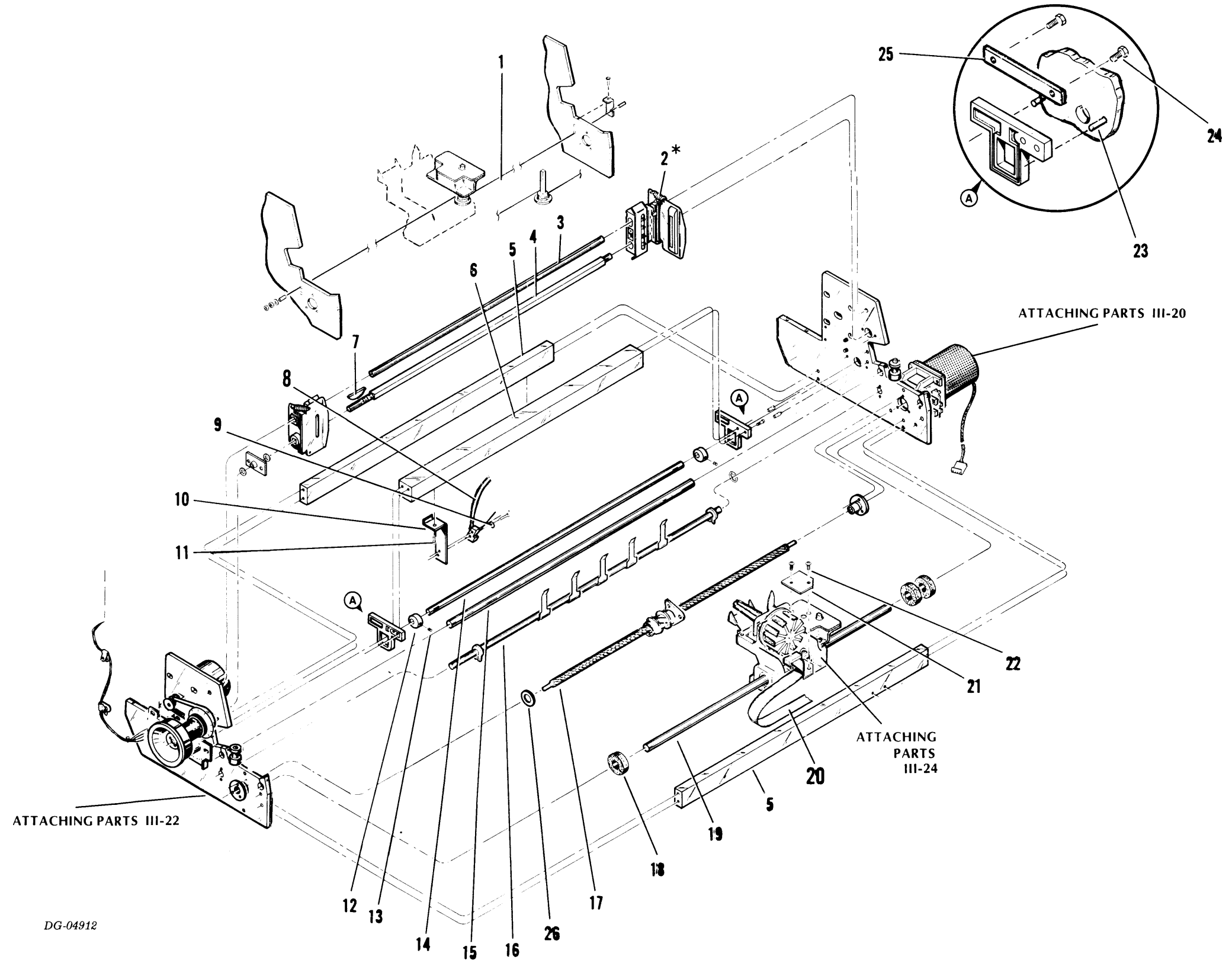

DG-04912

The drawings and parts lists contained herein are the property of DGC and shall neither be reproduced in whole or in part without DGC prior written approval nor be implied to grant any license to make, use, or sell equipment manufactured in accordance herewith.

PAGE & ITEM NO.	DESCRIPTION	QTY	DGC PART NO.	REF PAGE NO.
III-18	<b>MECHANISM</b>	<b>1</b>	<b>005009501</b>	III-18
	ATTACHING PARTS			III-20
	ATTACHING PARTS			III-22
	ATTACHING PARTS			III-24
1	CABLE CAPSTAN DR	1	118000696	
2*	PIN FEED PAPER HLDG. DEVICE	1	118000699	
3	SUPPORT SHAFT, PRINTER	1	002004121	
4	SHAFT DRIVE DASHER	1	002007016	
5	SPACER FRAME, PRINTER	2	002004122	
6	<b>PLATEN SERIAL PRINTER</b>	<b>1</b>	<b>005006227</b>	III-26
7	WOODRUFF KEY K1-3	1	123000852	
8	<b>CABLE, OUT OF FORM SWITCH</b>	<b>1</b>	<b>005006406</b>	III-26 III-42
9	WASHER FLAT #2	2	106000502	
10	SWITCH, BRACKET OUT OF FORM SW.	1	002004159	
11	SCREW PHH PNH SCDP SEMS 8-32X7/16	1	106000086	
12	ECCENTRIC COLLAR, PRINTER	2	002004116	
13	SCREW CUP PT. SET 8-32X1/4	2	106000787	
14	PLATEN ADJ SHAFT PRINTER	1	002004113	
15	GUIDE RAIL PRINTER REAR	1	002004106	
16	PAPER TENSION SPRING	1	002006550	
17	SCREW, LEAD, BI-DIRECTION ASSEMBLY	1	118000675	
18	BUMPER, CARRIAGE	3	002006167	
19	RAIL GUIDE, FRONT	1	002007448	
20	<b>PRINT HEAD TO DRIVER CABLE</b>	<b>1</b>	<b>005009575</b>	III-38 III-42
21	CLAMP CABLE	1	002006133	
22	SCREW SLTD RDH SELF TAP #6 X 1/2	2	106000689	
23	PIN, DOWEL	4	123000994	
24	SCREW HEX WASH. HD PLASTITE	4	106000868	
25	BAR NYLON	2	002006458	
26	SHIM WASHER	A/R	123000992	
	CLUTCH PULLEY 6040-43	1	002006459	
	SCREW PHH PNH PLASTITE #4X1/2 } INFORMATION NOT AVAILABLE	2	106000852	
	 *GENUINE PARTS TRACTORS USED ON MODELS GP 6075, GP 6086	 1	 118001043	

The drawings and parts lists contained herein are the property of DGC and shall neither be reproduced in whole or in part without DGC prior written approval nor be implied to grant any license to make, use, or sell equipment manufactured in accordance herewith.

# MECHANISM (CONTINUED)

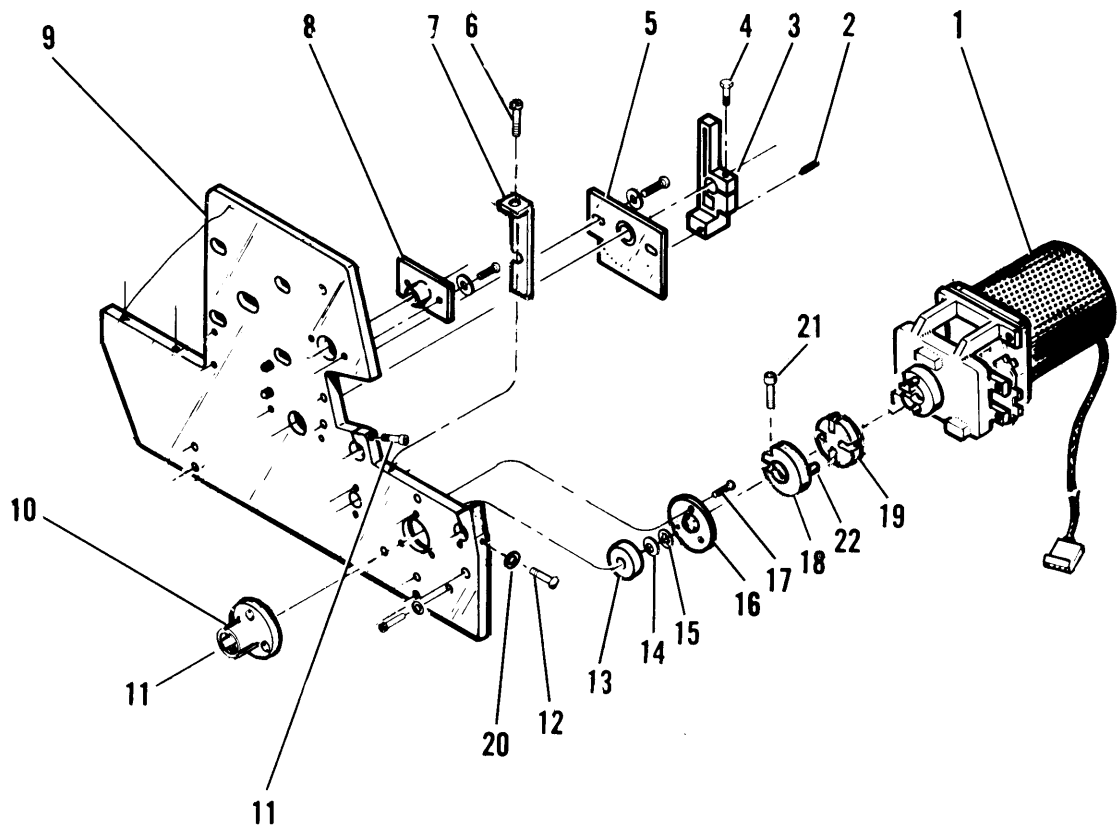

DG-04965

The drawings and parts lists contained herein are the property of DGC and shall neither be reproduced in whole or in part without DGC prior written approval nor be implied to grant any license to make, use, or sell equipment manufactured in accordance herewith.

PAGE & ITEM NO.	DESCRIPTION	QTY	DGC PART NO.	REF PAGE NO.
III-20	<b>MECH. (ATTACHING PARTS)</b>		<b>005009501</b>	III-18
1	<b>CARRIAGE DRIVE</b>	<b>REF</b>		III-32
2	SPRING PLUNGER 8-32X5/8	1	123000867	
3	PLATEN ADJUST LEVER, PRINTER	1	002004115	
4	HEX WASHER HD 4-20X3/4	1	106000867	
5	DETENT FLANGE PRINTER	1	002004133	
6	SCREW PHH PNH SEMS 8-32X1/4	1	106000083	
7	KEEPER, CABLE	1	002006168	
8	BEARING FLANGE, PRINTER	1	002004132	
9	END PLATE	1	002006173	
10	RETAINER, BUMPER PRINTER	1	002004103	
11	SCREW SCH. CAP #6-32 X 5/8	1	106000786	
12	SCREW 6-32 X 3/8 SOLID BRASS	2	106001034	
13	BALL BEARING	1	123000842	
14	WAVY WSHR SV-9	1	123000843	
15	SPACER BEARING	A/R	123000993	
16	RETAINER BEARING, PRINTER	1	002004104	
17	SCREW SLTD. BIND.HD. 4-40X1/2	6	106000282	
18	CLAMP COUPLING SHAFT	1	002007928	
19	SLIDE COUPLING	1	002006166	
20	WASHER LK SPLIT MED #6	1	106000691	
21	SCREW, CAP, BL. OXIDE 4-40 X 3/8	1	106000670	
22	PIN LOCK DOWEL 3/16 X .5	1	123001255	

The drawings and parts lists contained herein are the property of DGC and shall neither be reproduced in whole or in part without DGC prior written approval nor be implied to grant any license to make, use, or sell equipment manufactured in accordance herewith.

# MECHANISM (CONTINUED)

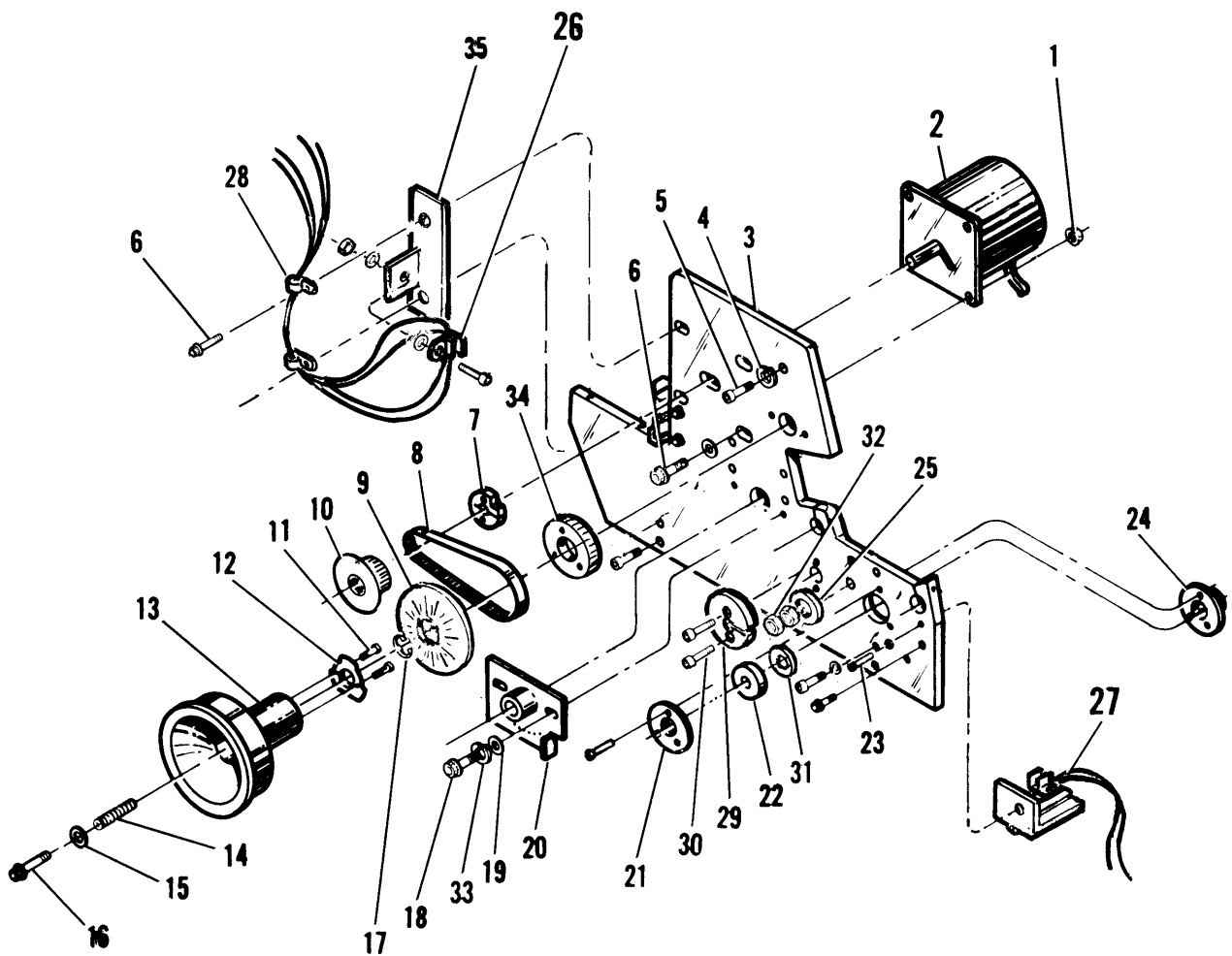

DG-04966

The drawings and parts lists contained herein are the property of DGC and shall neither be reproduced in whole or in part without DGC prior written approval nor be implied to grant any license to make, use, or sell equipment manufactured in accordance herewith.



PAGE & ITEM NO.	DESCRIPTION	QTY	DGC PART NO.	REF PAGE NO.
III-22	<b>MECH. ( ATTACHING PARTS)</b>		<b>005009501</b>	III-18
1	NUT HEX KEP 8-32	4	106000255	
2	<b>PAPER FEED MOTOR</b>	1	<b>005009508</b>	III-28 III-42
3	PLATE END	1	002006173	
4	WASHER LK SPLIT #8	4	106000746	
5	SCREW BL. OXIDE 8-32X5/8	13	106000863	
6	SCREW CAP SCH SCDP 8-32X3/4	4	106000436	
7	CLAMP PAPER TENSION SHAFT	1	002004134	
8	BELT, TIMING	1	123000946	
9	DISK SECTOR (REG. PRINT)	1	002006148	
10	PULLEY TIMING BELT	1	002006551	
11	SCREW PHH PNH PLASTITE 2-22X1/4	5	106000869	
12	CLUTCH PLATE	1	002006548	
13	KNOB ADJUSTMENT	1	002004146	
14	SPRING COMPRESSION, KNOB	1	123000851	
15	WASHER FLAT #8	4	106000264	
16	SCREW SCH FLH BL. OXIDE 4-40X3/8	1	106000603	
17	RETAINING RING 1/4	1	123000858	
18	SCREW CAP SCH SCDP 6-32X3/8	8	106000454	
19	WASHER FLAT #6	6	106000461	
20	DETENT FLANGE PRINTER	1	002004133	
21	RETAINER BEARING PRINTER	1	002004104	
22	BALL BEARING	1	123000842	
23	SCREW PLASTITE #8 X 1/2	1	106000865	
24	RETAINER, BUMPER PRINTER	1	002004103	
25	WASHER BELLVILLE SPRING	1	123001256	
26	<b>PAPER FEED TRANSDUCER CABLE</b>	1	<b>005009591</b>	III-36 III-42
27	<b>HOME TRANSDUCER CABLE</b>	1	<b>005009588</b>	III-36 III-42
28	CLAMP CABLE 1/8	2	123000101	
29	CLAMP PAPER TENSION, SHAFT	1	002004134	
30	SCREW 6-32 X 1/2	2	106000699	
31	SPACER SHAFT (SHIM)	A/R	123000992	
32	NUT, 6-32	2	106000261	
33	LK. WASHER #6	4	106000691	
34	CLUTCH PULLEY	1	002006549	
35	TRANSDUCER BRACKET	1	002006990	

The drawings and parts lists contained herein are the property of DGC and shall neither be reproduced in whole or in part without DGC prior written approval nor be implied to grant any license to make, use, or sell equipment manufactured in accordance herewith.

# MECHANISM (CONTINUED)

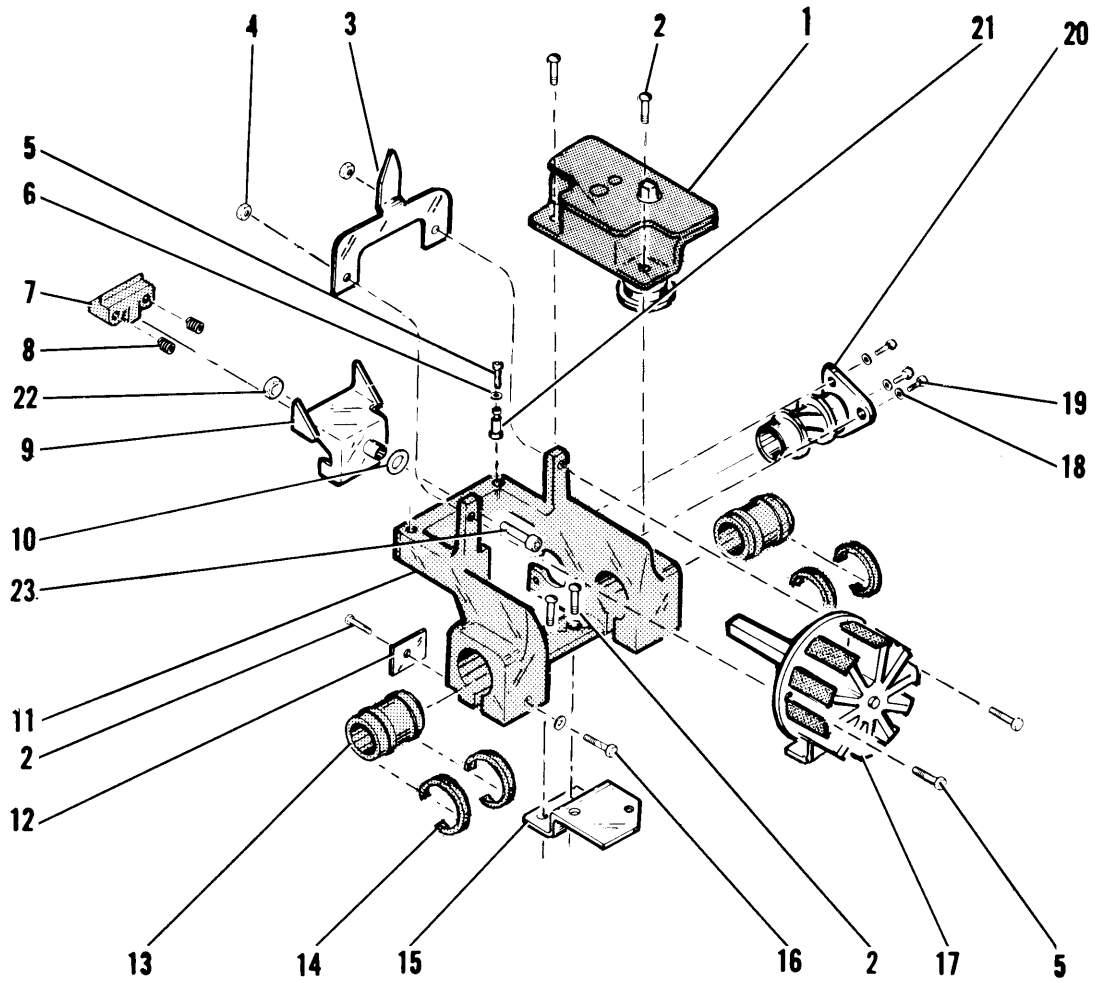

DG-04967

PAGE & ITEM NO.	DESCRIPTION	QTY	DGC PART NO.	REF PAGE NO.
	<b>MECH. (ATTACHING PARTS)</b>		<b>005009501</b>	<b>III-18</b>
1	<b>RIBBON DRIVE</b>	1	<b>005009509</b>	<b>III-30</b>
2	SCREW PHH PNH SEMS 6-32X1/4	5	106000479	
3	INDICATOR COLUMN	1	002006156	
4	NUT HEX KEP 4-40	2	106000257	
5	SCREW SCH CAP SCDP 4-40X1/2	3	106000482	
6	O-RING NEOPRENE	2	123001267	
7	SLIDE BEARING REAR	1	002006169	
8	SPRING COMPRESSION	2	123001330	
9	BEARING REAR	1	002006128	
10	WASHER BELLVILLE SPRING	1	123001260	
11	CARRIAGE	1	002006126	
12	FLAG HOME	1	002006135	
13	LINEAR BEARING .500 DIA	2	123001321	
14	RING RETAINER 7/8 OD	4	123001264	
15	BRACKET CABLE	1	002006132	
16	SCREW SCH CAP BLK OXIDE 6-32X3/4	2	106000540	
17	PRINthead, MODIFIED	1	118000573	
18	WASHER LK. SPLIT #8 MED.	8	106000746	
19	SCREW SOC. HD 8-32X3/8	3	106000453	
20	SCREW LEAD, BI-DIRECTION ASSEMBLY	1	118000675	
21	STUD-O-RING	2	002006129	
22	KEP NUT 6-32	1	106000256	
23	SCREW SOC. HEAD 6-32 X 5/8	1	106000787	

The drawings and parts lists contained herein are the property of DGC and shall neither be reproduced in whole or in part without DGC prior written approval nor be implied to grant any license to make, use, or sell equipment manufactured in accordance herewith.

# PLATEN SERIAL PRINTER & CABLE OUT OF FORMS SWITCH

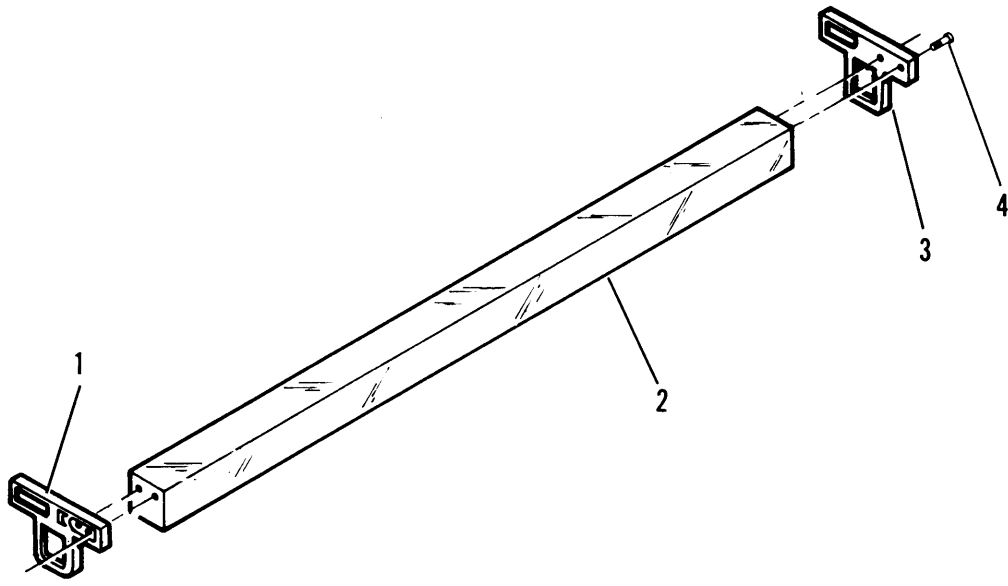

DG-04913

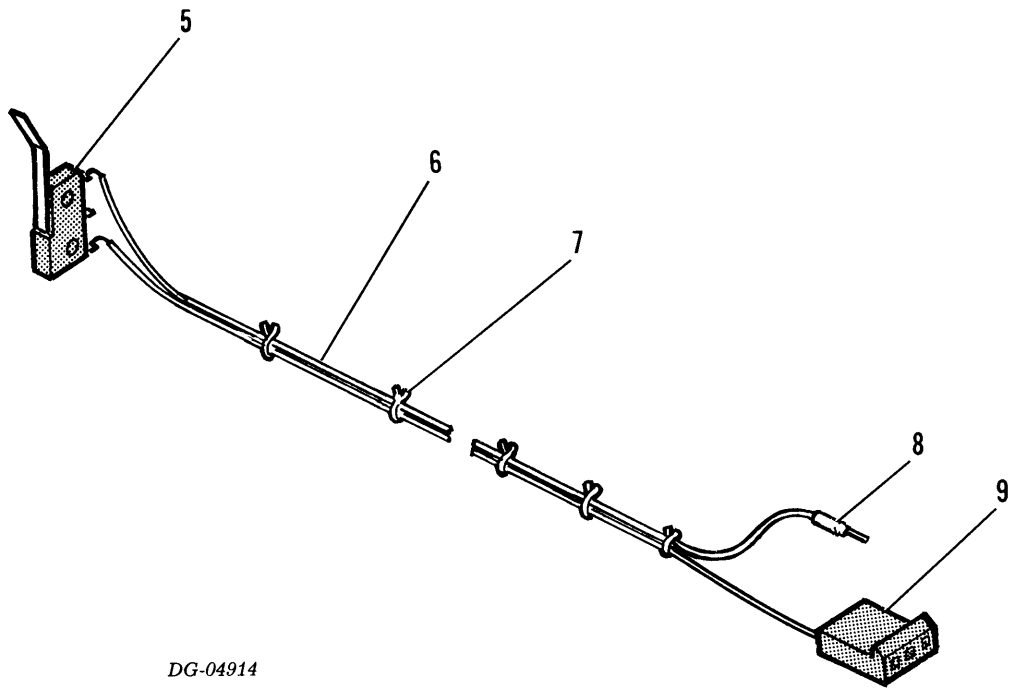

DG-04914

J24

PAGE & ITEM NO.	DESCRIPTION	QTY	DGC PART NO.	REF PAGE NO.
III-26	<b>PLATEN SERIAL PRINTER</b>	1	<b>005006227</b>	III-18
1	PLATEN SLIDE LH, PRINTER	1	002004112	
2	PLATEN, PRINTER	1	002004110	
3	PLATEN SLIDE, RH, PRINTER	1	002004111	
4	SCR CAP SCH SCDP 8-32X3/8	4	106000453	
III-26	<b>CA OUT OF FORM SWITCH SER PTR</b>	1	<b>005006406</b>	III-18 III-42
5	SWITCH E63-61HB	1	002006235	
6	WIRE TERMINATION	2	029001954	
	WIRE #22 AWG 19X34 WHT	1	109000009	
	TERMINAL 18X24 AWG	1	111000518	
7	STD PRT SSTIM 3/4"	5	123000025	
8	SLEEVING 3/32" HEAT SHRINK	1	109000098	
9	CONN PCB MOLEX 09-50-3021	1	111000562	

The drawings and parts lists contained herein are the property of DGC and shall neither be reproduced in whole or in part without DGC prior written approval nor be implied to grant any license to make, use, or sell equipment manufactured in accordance herewith.

# PAPER FEED MOTOR & CARRIAGE MOTOR

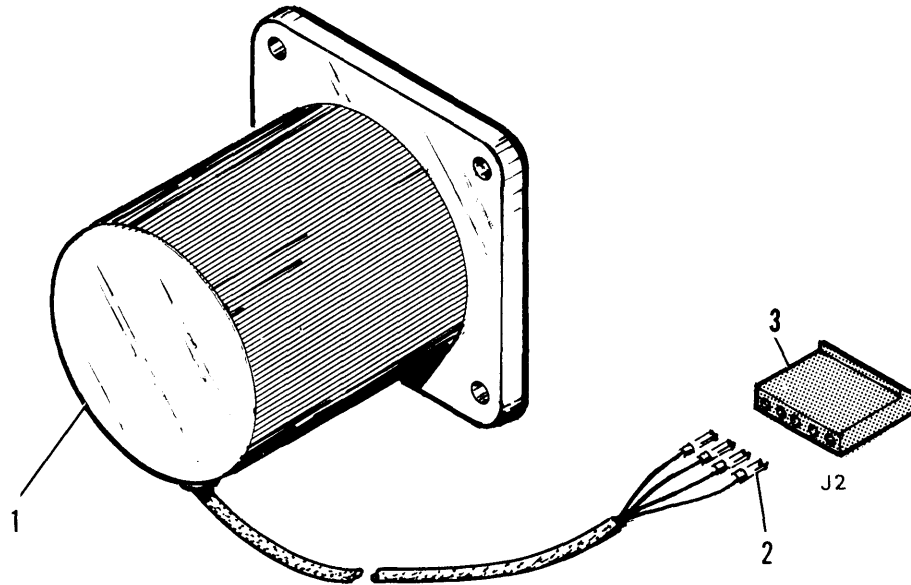

DG-04915

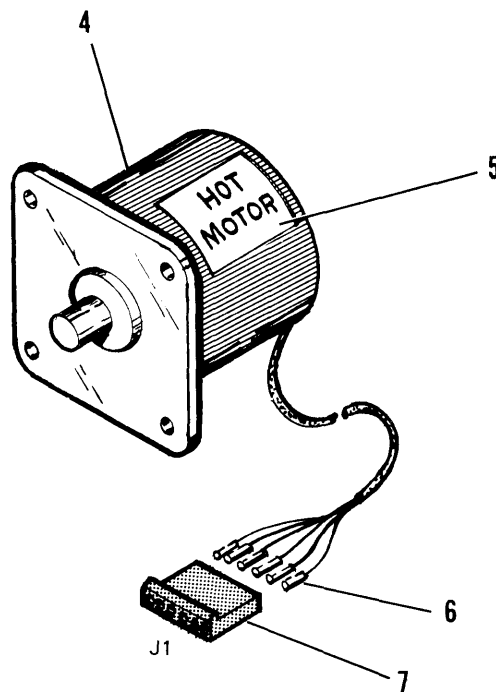

DG-04916

PAGE & ITEM NO.	DESCRIPTION	QTY	DGC PART NO.	REF PAGE NO.
III-28 1 2 3	<b>PAPER FEED MOTOR</b> MOTOR STEPPING 7.5DEG PUR ASSY TERM 2478 18-24AWG MOLEX 08-50-0105 CONN HSG 5P MOLEX 09-50-305	1 1 4 1	<b>005009508</b> 115000147 111000578 111000662	III-22
III-28 4 5 6 7	<b>CARRIAGE MOTOR</b> MOTOR STEPPING 2.5 DEGREE LBL HOT MOTOR TERM 2478 18-24AWG MOLEX 08-50-0105 CONN PCB MOLEX 09-50-3061	1 1 1 6 1	<b>005009511</b> 115000155 002008174 111000578 111000565	III-32   III-40

The drawings and parts lists contained herein are the property of DGC and shall neither be reproduced in whole or in part without DGC prior written approval nor be implied to grant any license to make, use, or sell equipment manufactured in accordance herewith.

## RIBBON DRIVE

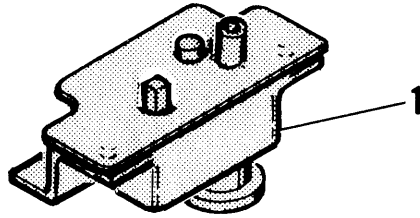

DG-04917

## RIBBON CARTRIDGE

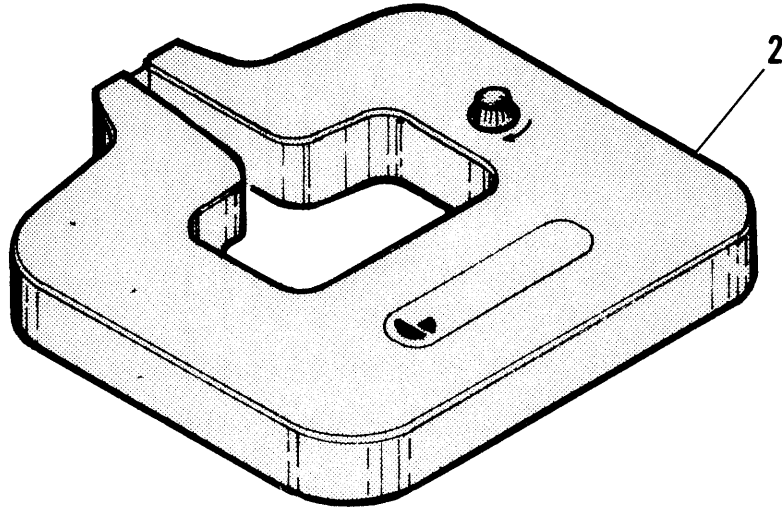

DG-04924



PAGE & ITEM NO.	DESCRIPTION	QTY	DGC PART NO.	REF PAGE NO.
III-30 1	RIBBON DRIVE	1	005009509	III-24
III-30 2	RIBBON CARTRIDGE BOX OF 12	1 REF	005009507 005010020	III-2

The drawings and parts lists contained herein are the property of DGC and shall neither be reproduced in whole or in part without DGC prior written approval nor be implied to grant any license to make, use, or sell equipment manufactured in accordance herewith.

**CARRIAGE DRIVE  
(WITH NORMAL PRINT DISC & TRANSDUCERS)**

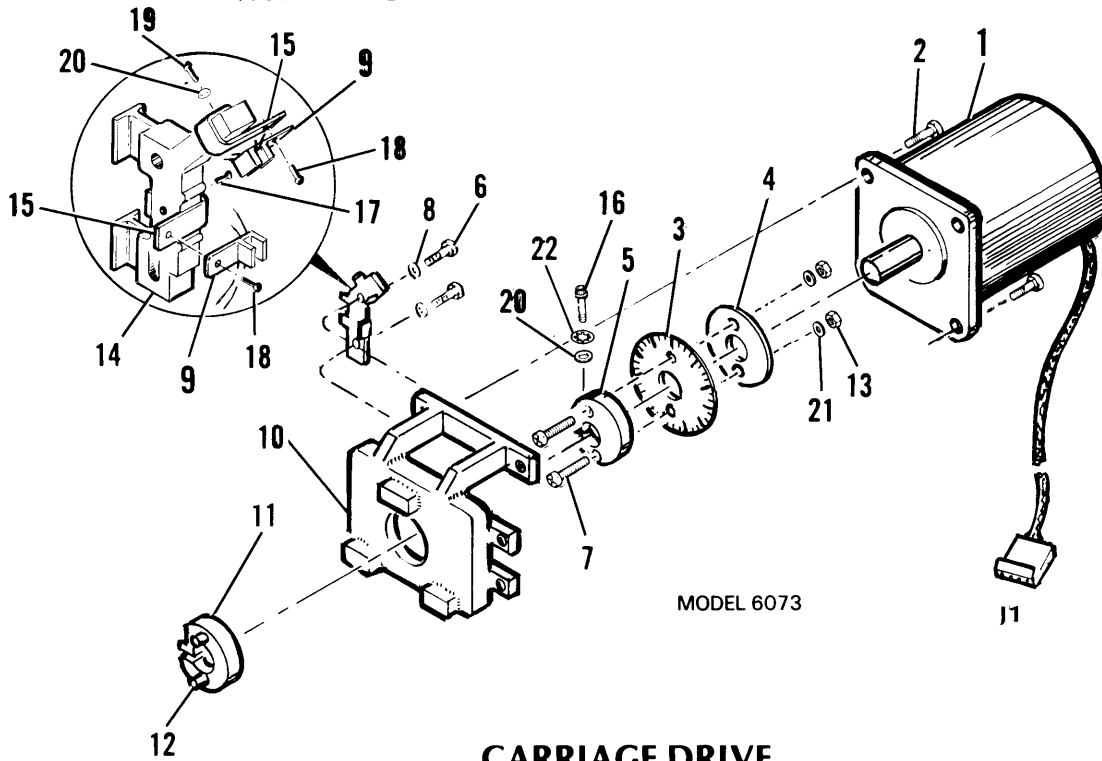

MODEL 6073

J1

**CARRIAGE DRIVE  
(WITH NORMAL & COMPRESSED PRINT  
& TRANSDUCERS)**

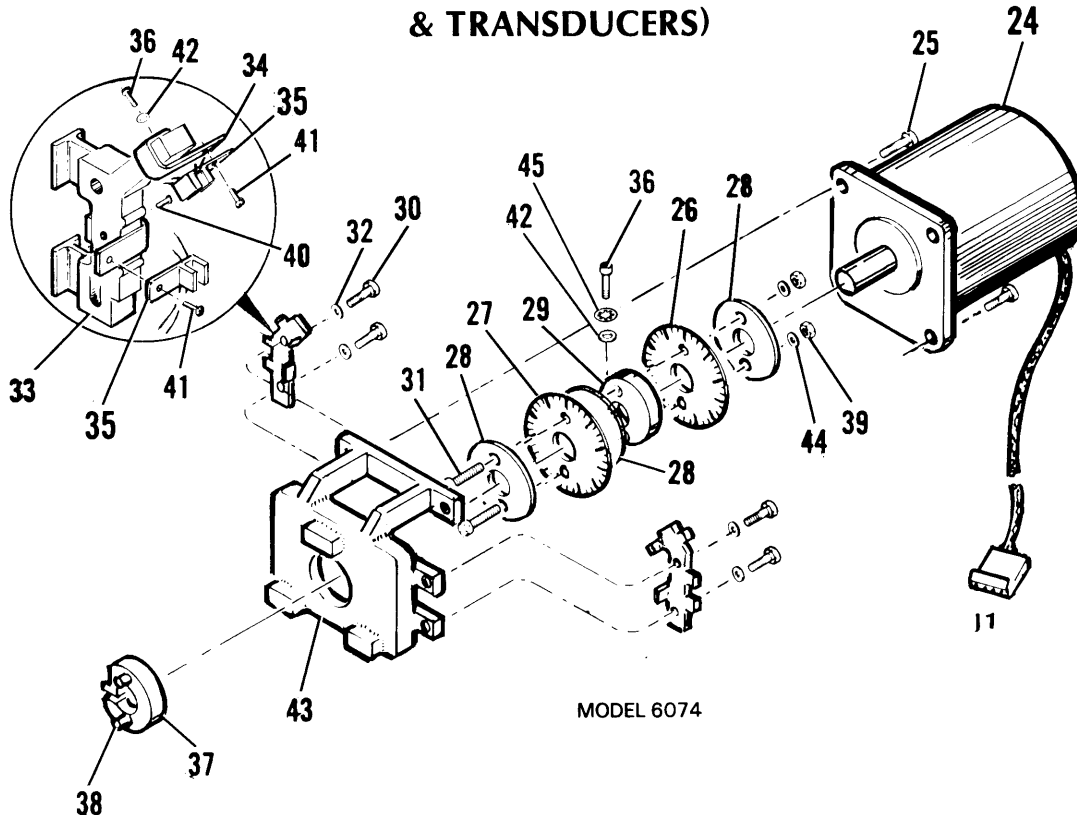

MODEL 6074

J1

DG-04918

The drawings and parts lists contained herein are the property of DGC and shall neither be reproduced in whole or in part without DGC prior written approval nor be implied to grant any license to make, use, or sell equipment manufactured in accordance herewith.

PAGE & ITEM NO.	DESCRIPTION	QTY	DGC PART NO.	REF PAGE NO.
III-32	<b>CARRIAGE DRIVE</b>	1	005009510	III-20
1	<b>CARRIAGE MOTOR</b>	1	005009511	III-28 III-42
2	SCR PHH PNH SCDP SEM 10-32 X 3/8	4	106000106	
3	DISK SECTOR (REG. PRINT)	1	002006148	
4	GIB DISK	1	002006155	
5	CLAMP DISK	1	002006154	
6	SCR PHH PNH SCDP SEMS 6-32 X 1/2	4	106000546	
7	SCR PHH PNH SCDP 4-40 X 9/16	2	106000035	
8	WASHER FLAT #6.156 X .375 X 049	4	106000461	
9	<b>TRANSDUCER</b>	1	005009591	III-34 III-42
10	BRKT. MOTOR	1	002006151	
11	CLAMP, COUPLING MOTOR	1	002007927	
12	PIN LOCK DOWEL 3/16 DIA. X .5 LG.	2	123001255	
13	HEX NUT KEP SCDP 4-40	2	106000257	
14	BAR MTG. TRANSDUCER	1	002006152	
15	MOUNT TRANSDUCER	2	002006153	
16	SCR CAP BL. OXIDE #2-56 X 1/2	1	106001489	
17	HEX WSHR HD. PLASTITE 4-20 X 3/8	1	106000842	
18	SCR PHH PNH PLASTITE 4-20 X 1/4	2	106001035	
19	SCR CAP BL. OXIDE 2-56 X 1/2	1	106001489	
20	WASHER FLAT #2	2	106000502	
21	WASH. FL. #4	2	106000265	
22	WASHER INT. TOOTH #2	2	106000267	
III-32	<b>CARRIAGE DRIVE COND. PRINT</b>	1	005010007	III-20
24	<b>CARRIAGE MOTOR</b>	1	005009511	III-28, III-42
25	SCREW PHH PNH SCDP SEM 10-32 X 3/8	4	106000106	
26	DISK SECTOR (REG PRINT)	1	002006148	
27	DISK SECTOR (COND PRINT)	1	002006149	
28	GIB DISK	3	002006155	
29	CLAMP DISK	1	002006154	
30	SCR PHH PNH SCDP SEMS 6-32 X 7/16	4	106000546	
31	SCR PHH PNH SCDP 4-40 X 9/16	2	106000065	
32	WSHR FL. #6.156 X .375 X .049	4	106000461	
33	BAR MTG TRANSDUCER	1	002006152	
34	MOUNT TRANSDUCER	1	002006153	
35	<b>TRANSDUCER</b>	2	005009591	III-34, III-42
36	SCR CAP BL OXIDE 2-56 X 1/2	3	106001489	
37	CLAMP COUPLING MOTOR	1	002007927	
38	PIN LK DOWEL 3/16 DIA X .5 LG.	4	123001255	
39	HEX NUT KEP SCDP 4-40	2	106000257	
40	HEX WASH HD. PLASTITE SCDP 4-20 X 3/8	1	106000842	
41	SCR PHH PNH PLASTITE SCDP 4-20 X 1/4	2	106001035	
42	WASHER FLAT #2	2	106000502	
43	BRKT MOTOR	1	002006151	
44	WASHER FL #4	2	106000265	
45	WASHER INT. TOOTH #2	2	106000267	

The drawings and parts lists contained herein are the property of DGC and shall neither be reproduced in whole or in part without DGC prior written approval nor be implied to grant any license to make, use, or sell equipment manufactured in accordance herewith.

**TRANSDUCER ASSEMBLY  
COMPRESSED ASSEMBLY**

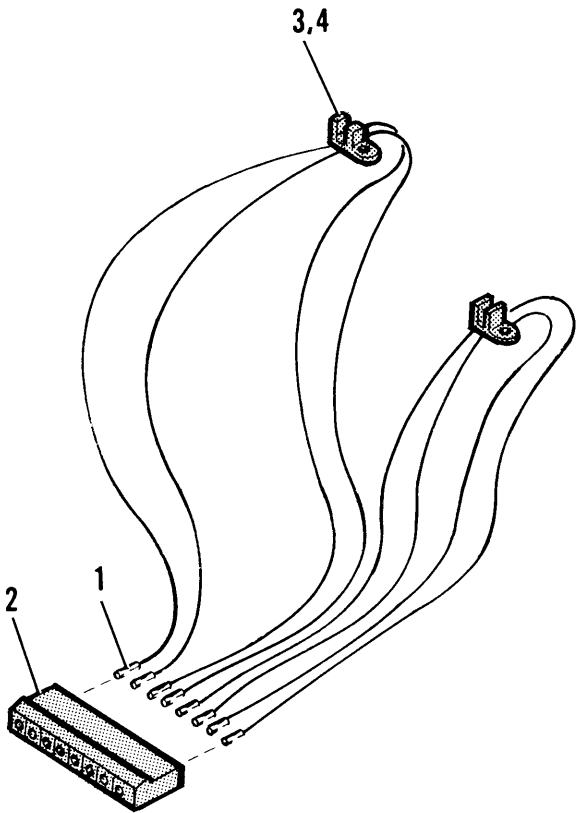

DG-04920

The drawings and parts lists contained herein are the property of DGC and shall neither be reproduced in whole or in part without DGC prior written approval nor be implied to grant any license to make, use, or sell equipment manufactured in accordance herewith.

PAGE & ITEM NO.	DESCRIPTION	QTY	DGC PART NO.	REF PAGE NO.
III-34				
	<b>TRANSDUCER ASSEMBLY</b>	1	<b>005009513</b>	III-32 III-42
1	TERMINAL 18-24 AWG	8	111000578	
2	CONN P.C.B.	1	111000566	
3	TRANSDUCER OPTICAL	2	118000513	
	<b>COMPRESSED ASSEMBLY</b>	1	<b>005012914</b>	
1	TERMINAL 18-24 AWG	8	111000578	
2	CONN P.C.B.	1	111000566	
4	TRANSDUCER OPTICAL	2	118001120	

The drawings and parts lists contained herein are the property of DGC and shall neither be reproduced in whole or in part without DGC prior written approval nor be implied to grant any license to make, use, or sell equipment manufactured in accordance herewith.

# HOME TRANSDUCER CABLE & PAPER FEED TRANSDUCER

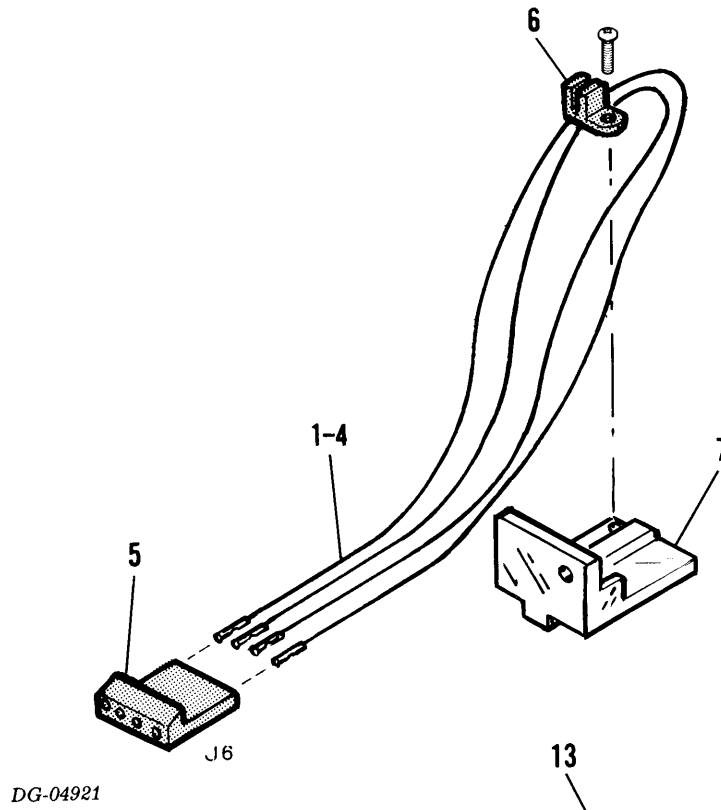

DG-04921

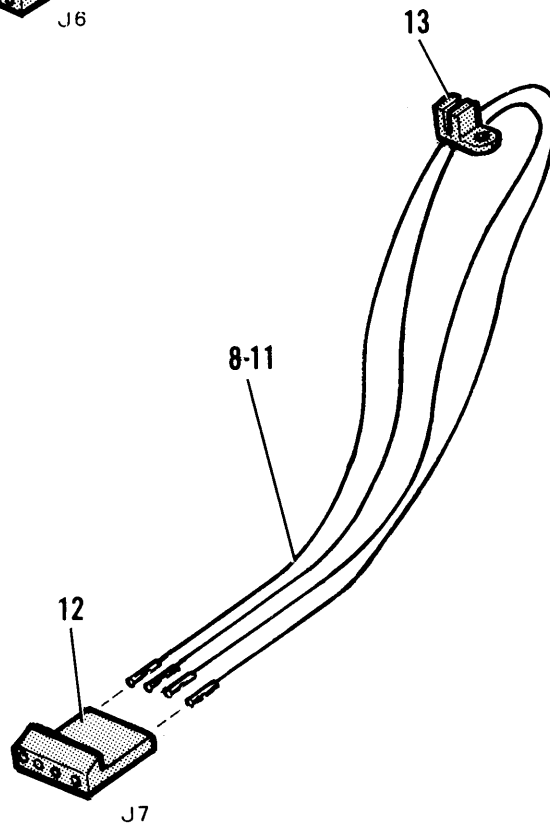

DG-04922

The drawings and parts lists contained herein are the property of DGC and shall neither be reproduced in whole or in part without DGC prior written approval nor be implied to grant any license to make, use, or sell equipment manufactured in accordance herewith.

PAGE & ITEM NO.	DESCRIPTION	QTY	DGC PART NO.	REF PAGE NO.
III-36	<b>HOME TRANSDUCER CABLE</b>	<b>1</b>	<b>005009588</b>	<b>III-22 III-42</b>
1	WIRE TERMINATION		029003025	
	WIRE #22AWG 19X34 GREEN I/PVC 3.16LG	1	109000011	
	TERM 2478 18-24AWG MOLEX 08-50-0105	1	111000578	
2	WIRE TERMINATION		029003026	
	WIRE #22AWG 19X34 ORANGE I/PVC 2.82LG	1	109000013	
	TERM 2478 18-24AWG MOLEX 08-50-0105	1	111000578	
3	WIRE TERMINATION		029003027	
	WIRE #22AWG 19X34 WHITE I/PVC 12.26LG	1	109000009	
	TERM 2478 18-24AWG MOLEX 08-50-0105	1	111000578	
4	WIRE TERMINATION		029003028	
	WIRE #22AWG 19X34 BLUE I/PVC 3.87LG	1	109000012	
	TERM 2478 18-24AWG MOLEX 08-50-0105	1	111000578	
5	CONN PCB MOLEX 09-50-3041	1	111000564	
6	XDCR, OPTICAL	1	118000513	
7	BRACKET		002006157	
III-36	<b>PAPER FEED TRANSDUCER CABLE</b>	<b>1</b>	<b>005009591</b>	<b>III-22 III-42</b>
8	WIRE TERMINATION		029003025	
	WIRE #22AWG 19X34 GREEN I/PVC 3.16LG	1	109000011	
	TERM 2478 18-24AWG MOLEX 08-50-0105	1	111000578	
9	WIRE TERMINATION		029003026	
	WIRE #22AWG 19X34 ORANGE I/PVC 2.82LG	1	109000013	
	TERM 2478 18-24AWG MOLEX 08-50-0105	1	111000578	
10	WIRE TERMINATION		029003027	
	WIRE #22AWG 19X34 WHITE I/PVC 12.26LG	1	109000009	
	TERM 2478 18-24AWG MOLEX 08-50-0105	1	111000578	
11	WIRE TERMINATION		029003028	
	WIRE #22AWG 19X34 BLUE I/PVC 3.87LG	1	109000012	
	TERM 2478 18-24AWG MOLEX 08-50-0105	1	111000578	
12	CONN PCB MOLEX 09-50-3041	1	111000564	
13	XDCR, OPTICAL	1	118000513	

The drawings and parts lists contained herein are the property of DGC and shall neither be reproduced in whole or in part without DGC prior written approval nor be implied to grant any license to make, use, or sell equipment manufactured in accordance herewith.

# PRINT HEAD TO DRIVE CABLE

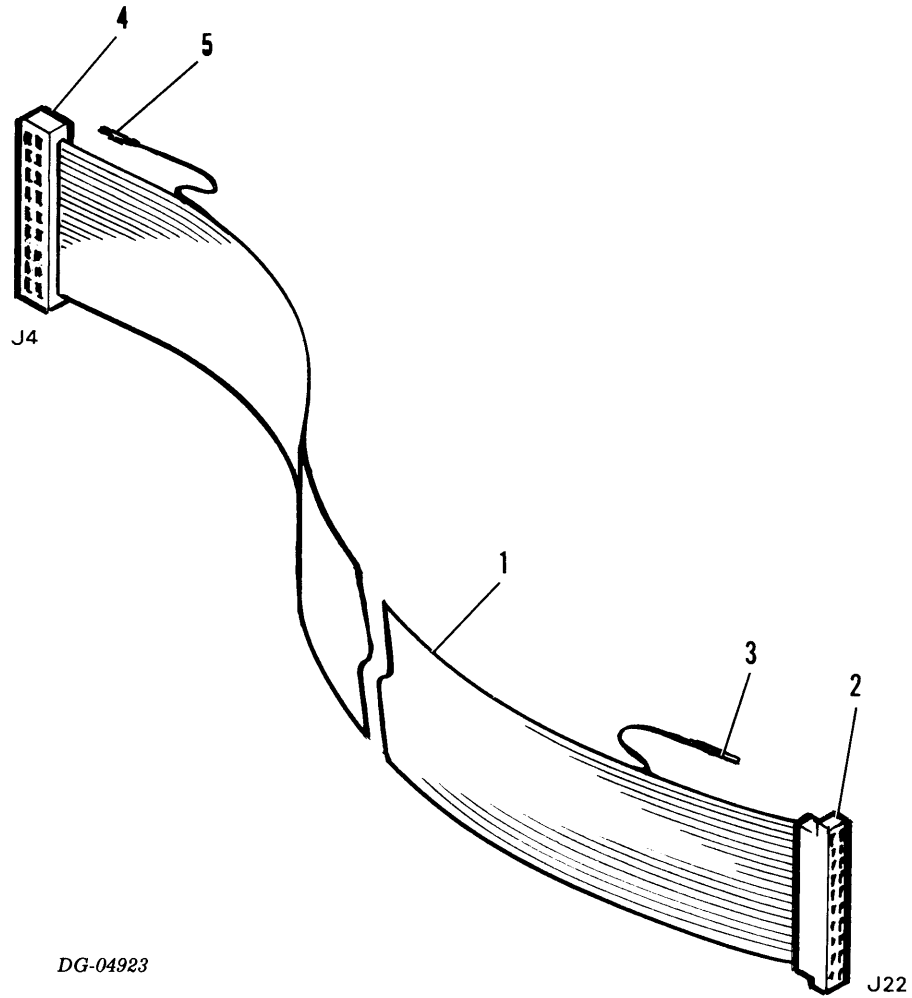

DG-04923



PAGE & ITEM NO.	DESCRIPTION	QTY	DGC PART NO.	REF PAGE NO.
III-38	<b>PRINT HEAD TO DRIVE CABLE</b>			
1	CABLE 20 COND	1	005009575	III-18 III-42
2	CONN CABLE	1	109000321	
3	CONN AMP	1	111000027	
4	CONN P.C. EDGE	20	111000058	
5	CONN CONT TW LEAF	1	111000119	
		20	111000343	

The drawings and parts lists contained herein are the property of DGC and shall neither be reproduced in whole or in part without DGC prior written approval nor be implied to grant any license to make, use, or sell equipment manufactured in accordance herewith.

EQUIPMENT LABELS

**CAUTION**

**USE ONLY DATA GENERAL RECOMMENDED  
RIBBON CARTRIDGES – P/N 005009507**

**USE OF NON-RECOMMENDED RIBBONS  
CAN RESULT IN PRINTHEAD DAMAGE**

1

**CAUTION  
HOT  
MOTOR**

2

**DANGER  
HIGH  
VOLTAGE**

3

DG-04927

PAGE & ITEM NO.	DESCRIPTION	QTY	DGC PART NO.	REF PAGE NO.
III-40				
1	LABEL "RIBBON CORRECT CTG."	1	002007938	III-2
2	LABEL "HOT MOTOR"	1	002008174	III-2 III-28
3	LABEL "DANGER HIGH VOLTAGE"	1	002003044	III-2

The drawings and parts lists contained herein are the property of DGC and shall neither be reproduced in whole or in part without DGC prior written approval nor be implied to grant any license to make, use, or sell equipment manufactured in accordance herewith.

# CABLE ROUTING DIAGRAM

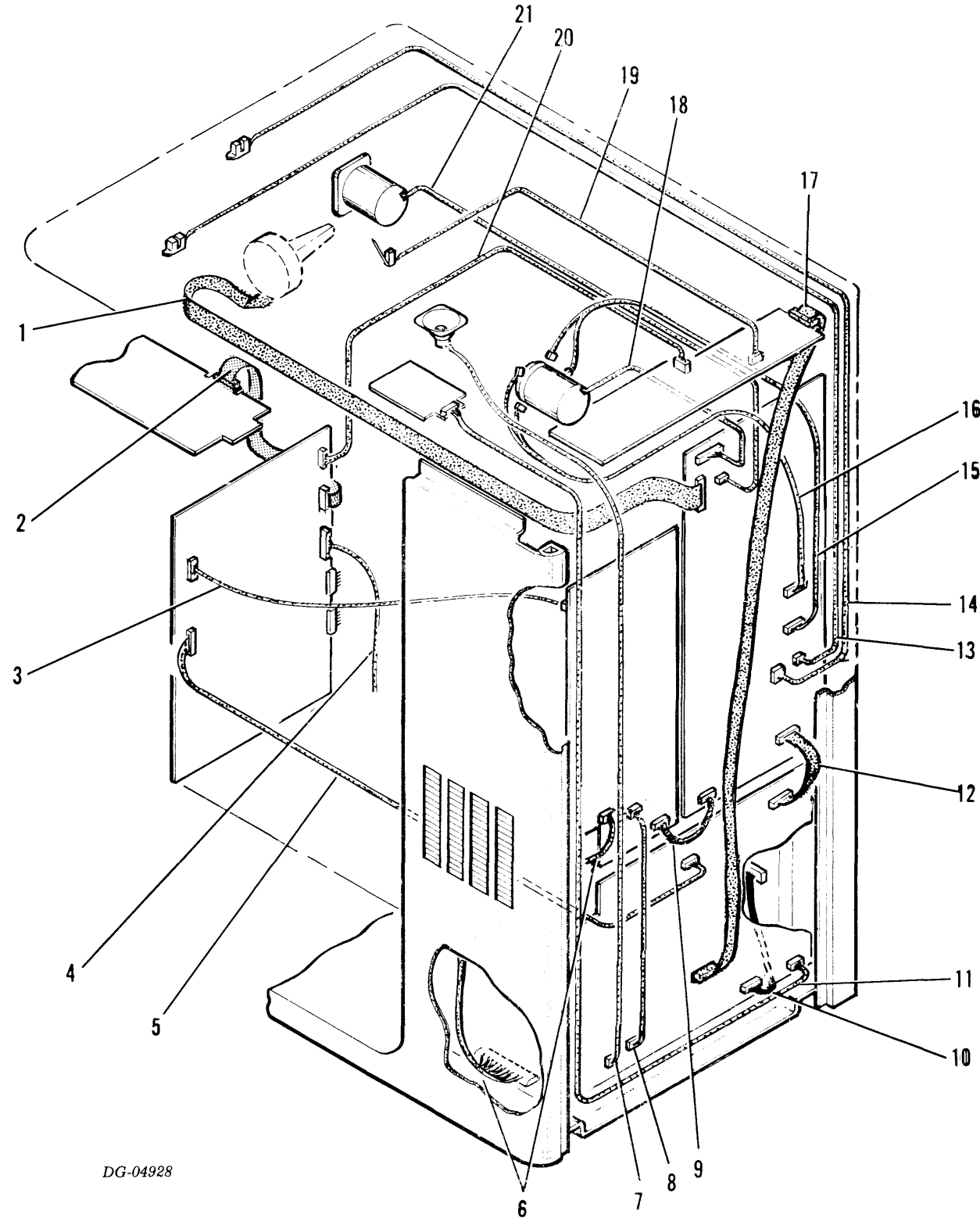

DG-04928

PAGE & ITEM NO.	DESCRIPTION	QTY	DGC PART NO.	REF PAGE NO.
1	<b>CABLE ROUTING DIAGRAM</b>	1	005009575	III-2
2	PRINT HD. TO DRIVER	1	005009577	
3	* CONTROL LOGIC TO KEYBOARD	1	005009592	
4	* P/S TO OPTION P.C.B.	1	005009597	
5	* PRINT HD. TO DRIVER	1	005009594	
6	* TO CONTROL P.C.B.	1	005009516	
7	POWER SUPPLY HARNESS	1	005009576	
8	CONTROL LOGIC TO BELL	1	005009578	
9	POWER SUPPLY TO CONTROL LOGIC	1	005009579	
10	P/S TO DRIVER	1	005009596	
11	CONTROL TO PAR. I/O	1	005009582	
12	CONTROL LOGIC TO CONT. PNL.	1	005009580	
13	DRIVER TO CONTROL LOGIC	1	005009588	
14	HOME TRANSDUCER	1	005009591	
15	PAPER FEED TRANSDUCER	1	005009513	
16	MOUNTED TRANSDUCER	1	005009513	
17	MOUNTED TRANSDUCER (COMPRESSED PRINT ONLY)	1	005009581	
18	CONTROL LOGIC TO SEC. CONTROL	1	005009511	
19	CARRIAGE MOTOR	1	005006406	
20	OUT OF FORMS SWITCH SER. P.T.R.	1	005009593	
21	* TO SEC. CONT. PANEL	1	005009508	
	PAPER FEED MOTOR	1		
	<b>* OPTION</b>			

The drawings and parts lists contained herein are the property of DGC and shall neither be reproduced in whole or in part without DGC prior written approval nor be implied to grant any license to make, use, or sell equipment manufactured in accordance herewith.

# INTERCONNECTION DIAGRAM

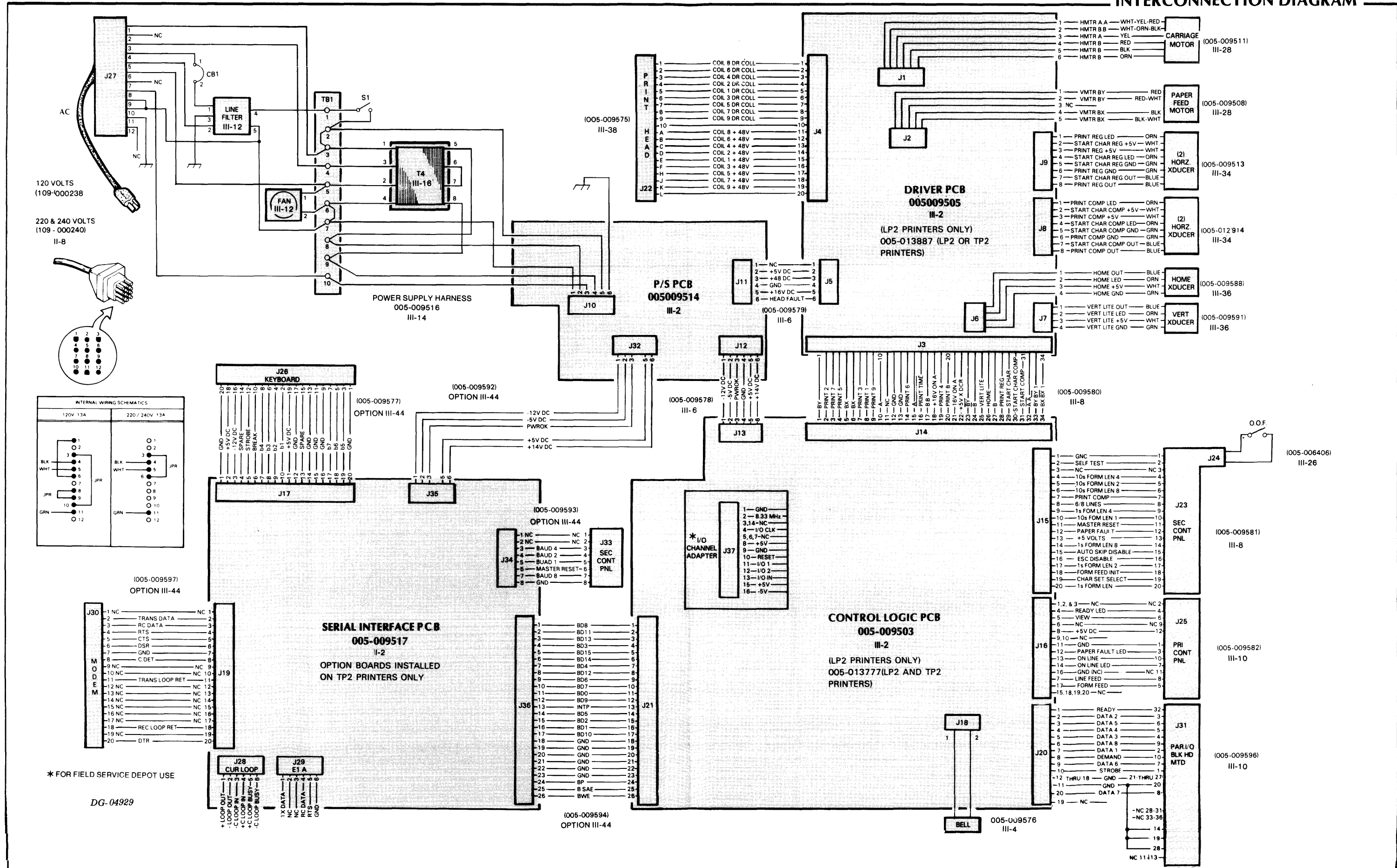



# APPENDIX A

## PREFIX CODE TABLE

PREFIX CODES	STANDARD TITLING	PREFIX CODES	STANDARD TITLING
001	SCHEMATIC	107	ARTWORK, PCB
002	MECH PT (MECHANICAL PART)	108	PUR TEST SPEC (TEST SPEC, PURCHASED PARTS)
005	ASSY (ASSEMBLY B/M PARTS LIST) ASSY DOC PKG (SHIPPED DOCUMENTS)	109	WIRE, CABLE, TUBING, SLEEVING
007	KEY (TOP ASSEMBLY B/M)	110	SWITCH, RELAY
008	WL (WIRE LIST FOR CABLES, TEST PLUGS AND INTERCONNECTION WIRING)	111	HSG (HOUSING), CONN (CONNECTOR), TERM (TERMINAL)
010	CONF (CONFIGURATION DRAWING)	112	CABINET
011	TEST EQPT (TEST EQUIPMENT)	113	FUSE, FUHLR (FUSE HOLDER)
015	TM (TECHNICAL MANUAL)	113	CIR BKR (CIRCUIT BREAKER)
016	IPL (PHYSICAL ILLUSTRATED PARTS LIST) IPB (ILLUSTRATED PARTS BREAKDOWN)	114	INDICATOR, BULB
029	WIRE PT (WIRE PART)	115	FAN, MOTOR, BLOWER
036	ECO KIT	116	CM (CIRCUIT MODULES)
037	PKG (PACKAGING)	117	SPEC TOOLS
042	TECHNICAL UPDATES	118	PUR ASSY (PURCHASED ASSEMBLY)
043	FIELD ENGINEERING PUBLICATIONS	118	PUR PRPHL (PURCHASED PERIPHERALS)
044	SHIPPING PACKAGING	119	MISC PT (MISCELLANEOUS PART)
100	IC (INTEGRATED CIRCUIT)	120	ADHVE (ADHESIVE), TAPE
101	XISTOR (TRANSISTORS), DIODES	120	CHEM (CHEMICALS)
102	RES (RESISTORS)	121	CRYSTAL
103	CAP (CAPACITORS)	123	STD PT (STANDARD PART)
104	XFMR (TRANSFORMER)	124	SOLENOIDS
105	CORE FERRITE	126	METAL STOCK
106	HDW (HARDWARE)	128	TOOL
		129	SHPG MAT (SHIPPING MATERIAL)

DG-03906

The drawings and parts lists contained herein are the property of DGC and shall neither be reproduced in whole or in part without DGC prior written approval nor be implied to grant any license to make, use, or sell equipment manufactured in accordance herewith.





# Engineering Publications Comment Form

Please help us improve our future publications by answering the questions below. Use the space provided for your comments.

Title: \_\_\_\_\_

Document No. \_\_\_\_\_

Yes	No		
<input type="checkbox"/>	<input type="checkbox"/>	is this manual easy to read?	<input type="radio"/> You (can, cannot) find things easily. <input type="radio"/> Other: <input type="radio"/> Language (is, is not) appropriate. <input type="radio"/> Technical terms (are, are not) defined as needed.
		In what ways do you find this manual useful?	<input type="radio"/> Learning to use the equipment <input type="radio"/> To instruct a class. <input type="radio"/> As a reference <input type="radio"/> Other: <input type="radio"/> As an introduction to the product
<input type="checkbox"/>	<input type="checkbox"/>	Do the illustrations help you?	<input type="radio"/> Visuals (are, are not) well designed. <input type="radio"/> Labels and captions (are, are not) clear. <input type="radio"/> Other:
<input type="checkbox"/>	<input type="checkbox"/>	Does the manual tell you all you need to know? What additional information would you like?	
<input type="checkbox"/>	<input type="checkbox"/>	Is the information accurate? (If not please specify with page number and paragraph.)	

Name: \_\_\_\_\_ Title: \_\_\_\_\_

Company: \_\_\_\_\_ Division: \_\_\_\_\_

Address: \_\_\_\_\_ City: \_\_\_\_\_

State: \_\_\_\_\_ Zip: \_\_\_\_\_ Telephone: \_\_\_\_\_ Date: \_\_\_\_\_

FOLD

FOLD

STAPLE

STAPLE

FOLD

FOLD



NO POSTAGE  
NECESSARY  
IF MAILED  
IN THE  
UNITED STATES

**BUSINESS REPLY MAIL**  
FIRST CLASS PERMIT NO. 26 SOUTHBORO, MA. 01772

Postage will be paid by addressee:

 **Data General**

ATTN: ENGINEERING PUBLICATIONS

Southboro, Massachusetts 01772

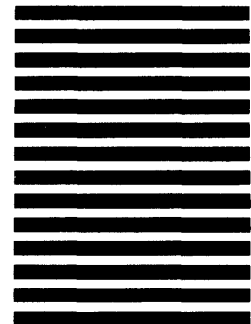

# **USERS** **group**

## Installation Membership Form

Name \_\_\_\_\_ Position \_\_\_\_\_ Date \_\_\_\_\_

Company, Organization or School \_\_\_\_\_

Address \_\_\_\_\_ City \_\_\_\_\_ State \_\_\_\_\_ Zip \_\_\_\_\_

Telephone: Area Code \_\_\_\_\_ No. \_\_\_\_\_ Ext. \_\_\_\_\_

### 1. Account Category

- OEM
- End User
- System House
- Government

### 5. Mode of Operation

- Batch (Central)
- Batch (Via RJE)
- On-Line Interactive

### 2. Hardware

- M/600
- C/350, C/330, C/300
- S/250, S/230, S/200
- S/130
- AP/130
- CS Series
- N3/D
- Other NOVA
- microNOVA
- Other \_\_\_\_\_
- (Specify) \_\_\_\_\_

Qty. Installed	Qty. On Order

### 6. Communications

- RSTCP
- HASP
- RJE80
- SAM
- CAM
- 4025
- Other

Specify \_\_\_\_\_

### 3. Software

- AOS
- DOS
- SOS
- RDOS
- RTOS
- Other

Specify \_\_\_\_\_

### 7. Application Description

○ \_\_\_\_\_

\_\_\_\_\_

\_\_\_\_\_

\_\_\_\_\_

\_\_\_\_\_

### 4. Languages

- Algol
- DG/L
- Cobol
- ECLIPSE Cobol
- Business BASIC
- BASIC
- Assembler
- Interactive
- Fortran
- RPG II
- PL/1
- Other

Specify \_\_\_\_\_

### 8. Purchase

From whom was your machine(s) purchased?

- Data General Corp.
  - Other
- Specify \_\_\_\_\_

### 9. Users Group

Are you interested in joining a special interest or regional Data General Users Group?

○ \_\_\_\_\_

\_\_\_\_\_

FOLD

FOLD

STAPLE

STAPLE

FOLD

FOLD



**BUSINESS REPLY MAIL**  
FIRST CLASS PERMIT NO. 26 SOUTHBORO, MA. 01772

Postage will be paid by addressee:

 **Data General**

ATTN: Users Group Coordinator

Southboro, Massachusetts 01772

NO POSTAGE  
NECESSARY  
IF MAILED  
IN THE  
UNITED STATES

